

3-10-2010

Stealthy River Navigation in Jungle Combat Conditions

Fabio Ayres Cardoso

Follow this and additional works at: <https://scholar.afit.edu/etd>

 Part of the [Operations and Supply Chain Management Commons](#)

Recommended Citation

Cardoso, Fabio Ayres, "Stealthy River Navigation in Jungle Combat Conditions" (2010). *Theses and Dissertations*. 2082.
<https://scholar.afit.edu/etd/2082>

This Thesis is brought to you for free and open access by the Student Graduate Works at AFIT Scholar. It has been accepted for inclusion in Theses and Dissertations by an authorized administrator of AFIT Scholar. For more information, please contact richard.mansfield@afit.edu.



**STEALTHY RIVER NAVIGATION IN
JUNGLE COMBAT CONDITIONS**

THESIS

Fabio Ayres Cardoso, Captain, Brazilian Air Force

AFIT/LSCM/ENS/10-02

**DEPARTMENT OF THE AIR FORCE
AIR UNIVERSITY**

AIR FORCE INSTITUTE OF TECHNOLOGY

Wright-Patterson Air Force Base, Ohio

APPROVED FOR PUBLIC RELEASE; DISTRIBUTION UNLIMITED.

The views expressed in this thesis are those of the author and do not reflect the official policy or position of the United States Air Force, Department of Defense, the United States Government, the Brazilian Air Force, the Brazilian Ministry of Defense, or the Brazilian States Government.

AFIT/LSCM/ENS/10-02

STEALTHY RIVER NAVIGATION IN JUNGLE COMBAT CONDITIONS

THESIS

Presented to the Faculty

Department of Operational Sciences

Graduate School of Engineering and Management

Air Force Institute of Technology

Air University

Air Education and Training Command

In Partial Fulfillment of the Requirements for the

Degree of Master of Science in Logistics and Supply Chain Management

Fabio Ayres Cardoso, BS

Captain, Brazilian Air Force

March 2010

APPROVED FOR PUBLIC RELEASE; DISTRIBUTION UNLIMITED.

Abstract

One of the biggest challenges for Brazilian military logisticians is to support effective jungle warfare for both real and training operations carried out by their combat forces in the Amazonian region. The jungle's heat, humidity, and dense vegetation put significant demands on the supply chain. Further, because of the difficulties of land or air transportation, water transport is the most reasonable transportation option to sustain these deployed forces. Planners must select from among the available watercourses those whose surroundings provide stealthy navigation to the combat force location where the requested supplies can be safely unloaded. We seek a method of determining a path through a river network that blends short transit times with maximal shade coverage from forest growth along the riverbanks. We combine an astronomical algorithm for computing shadow coverage with Dijkstra's shortest path algorithm to determine the start time and routing information necessary for a supply boat to travel from a depot to a resupply point that minimizes weighted risk, which is defined as the product of shade coverage and arc transit time.

To my family who sacrificed dearly this 18 months

Acknowledgments

I would like to express my sincere appreciation to my advisor, Dr. Alan Johnson, for his insight and guidance during this research. I am also indebted to my reader, Major Daniel Mattioda, who endured my writing and provided valuable input from the very beginning of this work. The support you both provided is certainly appreciated.

A special thanks to my classmates, mainly other International Students, who were very supportive throughout this program. I truly valued your contributions, team efforts, and friendship. I hope we can remain in touch.

I am also indebted to Mrs. Annette Robb, International Military Student Officer, and Mrs. Clara Delgado, from the University of Dayton, for their encouraging, contributions in new language adaptation. Their participation was central to the success of this study.

My family assumed extra heavy burdens this past year so that I could focus on my studies and research. Without their support, I would fall short every time. A heartfelt appreciation is reserved for my beloved partner in life, my wife, who did an outstanding job managing the home front so that I could complete this research and program.

Fabio Ayres Cardoso

Table of Contents

| | Page |
|--|------|
| Abstract | iv |
| Dedication | v |
| Acknowledgments..... | vii |
| List of Figures | viii |
| List of Tables | ix |
| I. Introduction | 1 |
| Background | 1 |
| Problem Statement | 14 |
| Research Focus | 15 |
| Research Objectives..... | 16 |
| Theoretical Lens..... | 17 |
| Methodology | 18 |
| Assumptions..... | 18 |
| Limitations | 19 |
| Implications..... | 20 |
| II. Literature Review..... | 21 |
| Introduction..... | 21 |
| Military Perspectival Studies | 23 |
| Civilian Perspectival Studies | 25 |
| Synthesis | 34 |
| III. Methodology | 36 |
| Introduction..... | 36 |
| Manual Solar Position Calculation Model..... | 39 |
| Manual Risk and Vulnerability Calculation Model..... | 42 |
| Survivability Alternative Approaches..... | 52 |
| Graph Algorithms | 55 |
| Dijkstra's Algorithm | 57 |
| IV. Results and Analysis | 60 |
| Introduction..... | 60 |
| Problem Model Representation..... | 60 |
| Verification Processes..... | 62 |

| | Page |
|--|------|
| Data Analysis | 63 |
| Validation Process | 67 |
| Extreme Condition Tests..... | 68 |
| Cause-Effect Graphing..... | 74 |
| Predictive Validation | 88 |
| Synthesis | 92 |
| V. Discussion..... | 93 |
| Introduction..... | 93 |
| Insights..... | 93 |
| Assumptions and Limitations | 95 |
| Future Researches | 96 |
| Appendix A. Geographic Coordinates of the Theoretical Network Locations..... | 99 |
| Appendix B. Model Code in VBA..... | 101 |
| Appendix C. Blue Dart | 143 |
| Appendix D. Quad Chart | 146 |
| Bibliography | 147 |
| Vita | 154 |

List of Figures

| | Page |
|---|------|
| Figure 1. Brazilian Army simulating a real tactical infiltration mission..... | 1 |
| Figure 2. Embraer Super Tucano Brazilian aircraft | 1 |
| Figure 3. Brazilian amphibious commandos in riverine warfare training program | 2 |
| Figure 4. Brazilian Air Force’s Infantry in guerrilla tactics training | 2 |
| Figure 5. The 82nd Artillery, during the monsoon seasons, in the Vietnam War..... | 3 |
| Figure 6. The mudded conditions road passes through Hukawng-Mogaung Valley (Burma), during the Second World War..... | 3 |
| Figure 7. Filipino volunteers carry supplies into the mountains to reach 1st Cavalry Division troops in the Province of Leyte, during the Second World War..... | 5 |
| Figure 8. A long line of porters carry supplies along the Ho Chi Minh Trail for the North Vietnamese, during the Vietnam War. | 5 |
| Figure 9. Native carriers bringing supplies through the jungles into the hills, in the Guadalcanal Island, during the American Pacific Offensive in 1942..... | 5 |
| Figure 10. Parachute resupply in the Malayan jungle | 7 |
| Figure 11. Successful air resupply occurred in open areas instead of inside the dense wood..... | 7 |
| Figure 12. “Muletrain”: A Chindit column moving through Burmese Jungle..... | 8 |
| Figure 13. Mars Task Force mule skimmers (2d Bn., 475th Inf. Regt.) lead mules through the swift river that impeded their progress to Bhamo, Burma | 8 |
| Figure 14. A British soldier is interviewed by a doctor of 154th Field Ambulance, RAMC, in Burma..... | 11 |
| Figure 15. A wounded United States paratrooper waiting for medical evacuation at Base Camp in the A Shau Valley near the Laos border in South Vietnam during the Vietnam War..... | 11 |
| Figure 16. An Amazon River affluent..... | 13 |

| | Page |
|--|------|
| Figure 17. The Amazon basin's immensity | 13 |
| Figure 18. Brazilian UH-60 Blackhawks over the Amazon River in operational training | 14 |
| Figure 19. Brazilian Navy's fast patrol craft employed to fast deployment during riverine operations | 14 |
| Figure 20. Riverine forest of an Amazon affluent..... | 16 |
| Figure 21. Shadows produced by riverine forest..... | 16 |
| Figure 22. A camouflaged truck towing a 122mm gun in February 1973 | 24 |
| Figure 23. Bicycles laden with supplies in the Ho Chi Minh Trail..... | 24 |
| Figure 24. A group of walking North Vietnamese on the Ho Chi Minh trail | 25 |
| Figure 25. A Serial of camouflaged supply depots set up through-out the Ho Chi Minh trail. | 25 |
| Figure 26. An example of stealthy and non-stealthy traverses shown on the global potential field | 27 |
| Figure 27. Shadow regions casting behind objects from the observer's position | 27 |
| Figure 28. Picture showing a real robot movement which applied the sneaky behavior..... | 28 |
| Figure 29. Layout presenting a path following by a stealth behavior-based robot | 28 |
| Figure 30. Safety-Reachable (RS) corridor | 30 |
| Figure 31. Search area with 400 hexagons cells | 34 |
| Figure 32. An example of heuristic optimal path..... | 34 |
| Figure 33. Major attributes used to calculate the risk on each path (river)..... | 39 |
| Figure 34. The major attributes to risk level calculation on each path | 45 |
| Figure 35. Both Solar and Path Azimuths are in first quadrant (I) | 46 |

| | Page |
|---|------|
| Figure 36. Both Solar and Path Azimuths are in first quadrant (II) | 46 |
| Figure 37. Path Azimuth is in the first quadrant and Solar Azimuth is in the second one (I) | 46 |
| Figure 38. Path Azimuth is in the first quadrant and Solar Azimuth is in the second one (II) | 46 |
| Figure 39. Path Azimuth is in the first quadrant and Solar Azimuth is in the third one (I) | 47 |
| Figure 40. Path Azimuth is in the first quadrant and Solar Azimuth is in the third one (II) | 47 |
| Figure 41. Path Azimuth is in the first quadrant and Solar Azimuth is in the fourth one (I) | 47 |
| Figure 42. Path Azimuth is in the first quadrant and Solar Azimuth is in the fourth one (II) | 47 |
| Figure 43. Solar Azimuth is in the first quadrant and Path Azimuth is in the second one (I) | 48 |
| Figure 44. Solar Azimuth is in the first quadrant and Path Azimuth is in the second one (II) | 48 |
| Figure 45. Solar Azimuth is in the first quadrant and Path Azimuth is in the third one (I) | 48 |
| Figure 46. Solar Azimuth is in the first quadrant and Path Azimuth is in the third one (II) | 48 |
| Figure 47. Both Solar Azimuth and Path Azimuth are in the second quadrant (I) | 49 |
| Figure 48. Both Solar Azimuth and Path Azimuth are in the second quadrant (II) | 49 |
| Figure 49. Solar Azimuth is in second quadrant and Path Azimuth is in the third one (I) | 49 |
| Figure 50. Solar Azimuth is in second quadrant and Path Azimuth is in the third one (II) | 49 |

| | Page |
|---|------|
| Figure 51. Both Solar and Path Azimuths are in the third quadrant (I) | 50 |
| Figure 52. Both Solar and Path Azimuths are in the third quadrant (II) | 50 |
| Figure 53. Path Azimuths is in the third quadrant and Solar Azimuth is in the fourth one (I)..... | 50 |
| Figure 54. Path Azimuths is in the third quadrant and Solar Azimuth is in the fourth one (II) | 50 |
| Figure 55. Both Path and Solar Azimuths are in the fourth quadrant (I) | 51 |
| Figure 56. Both Path and Solar Azimuths are in the fourth quadrant (II)..... | 51 |
| Figure 57. Theoretical network plot..... | 61 |
| Figure 58. Amazon region satellite picture | 61 |
| Figure 59. Theoretical network based on real watercourse system..... | 62 |
| Figure 60. Excel Spreadsheet screenshot showing the relationship among the solar position parameters and timeframe (on March 21th 2010, at 8:00am)..... | 64 |
| Figure 61. Excel Spreadsheet screenshot showing the relationship among the solar position parameters and timeframe (on March 21th 2010, at 7:00am)..... | 64 |
| Figure 62. NOAA Solar Calculation screenshot showing the relationship among the solar position parameters and timeframe (on March 21th 2010, at 8:00am). | 65 |
| Figure 63. NOAA Solar Calculation screenshot showing the relationship among the solar position parameters and timeframe (on March 21th 2010, at 7:00am). | 65 |
| Figure 64. Excel VBA screenshot showing the path azimuth calculation, between nodes 1 and 2, computed by program computer | 66 |
| Figure 65. FCC Distance and Azimuth Calculation showing the path azimuth between nodes 1 and 2 | 66 |
| Figure 66. Input Spreadsheet's Excel screenshot, considering 30-minute interval departure | 69 |

| | Page |
|---|------|
| Figure 67. Output Spreadsheet's Excel screenshot, considering 30-minute interval departure | 69 |
| Figure 68. Output Spreadsheet's Excel screenshot, considering 15-minute interval departure | 70 |
| Figure 69. Graphic presenting the boat capability of surviving the supply mission under the absence of tree through-out the complete route, with 30-minute interval departure. Regardless start time, if one path has risk 1, the probability of mission success will be zero | 70 |
| Figure 70. Graphic presenting the boat capability of surviving the supply mission under tree absence throughout the complete route, emphasizing the importance of travel time, with 30-minute interval departure | 70 |
| Figure 71. Graphic presenting the relative travel risk throughout the complete route, with 30-minute interval departure..... | 71 |
| Figure 72. Graphic presenting the boat capability of surviving the supply mission under tree absence throughout the complete route, emphasizing the importance of travel time, with 15-minute interval departure | 71 |
| Figure 73. Input Spreadsheet's Excel screenshot, considering 30-minute interval departure | 72 |
| Figure 74. Output Spreadsheet's Excel screenshot, considering 30-minute interval departure | 72 |
| Figure 75. Output Spreadsheet's Excel screenshot, considering 15-minute interval departure | 73 |
| Figure 76. Graphic presenting the boat capability of surviving the supply mission under higher tree path condition throughout the complete route, with 30-minute interval departure | 73 |
| Figure 77. Graphic presenting the boat capability of surviving the supply mission under higher tree path condition throughout the complete route, emphasizing the importance of travel time, with 30-minute interval departure.... | 73 |
| Figure 78. Graphic presenting the relative travel risk under higher tree path condition throughout the complete route, with 30-minute interval departure | 74 |

| | Page |
|--|------|
| Figure 79. Graphic presenting the boat capability of surviving the supply mission under higher tree path condition through-out the complete route, emphasizing the importance of travel time, with 15-minute interval departure..... | 74 |
| Figure 80. Input Spreadsheet's Excel screenshot, considering a boat with rates 1.86 miles per hour | 75 |
| Figure 81. Output Spreadsheet's Excel screenshot, considering a boat with rates 1.86 miles per hour | 75 |
| Figure 82. Output Spreadsheet's Excel screenshot, considering a boat with rates 3.11 miles per hour | 76 |
| Figure 83. Output Spreadsheet's Excel screenshot, considering a boat with rates 6.21 miles per hour | 76 |
| Figure 84. Output Spreadsheet's Excel screenshot, considering a boat with rates 9.32 miles per hour | 77 |
| Figure 85. Graphic presenting the boat capability of surviving the supply mission, give rate 1.86 miles per hour, with 30-minute interval departure..... | 77 |
| Figure 86. Graphic presenting the boat capability of surviving the supply mission, give rate it speeds 1.86 miles per hour, emphasizing the importance of travel time, with 30-minute interval departure | 77 |
| Figure 87. Graphic presenting the relative travel risk, given a boat that with rate 1.86 miles per hour, with 30-minute interval departure..... | 78 |
| Figure 88. Graphic presenting the boat capability of surviving the supply mission, given rate 1.86 miles per hour, emphasizing the importance of travel time, with 15-minute interval departure..... | 78 |
| Figure 89. Graphic presenting the boat capability of surviving the supply mission, given rate it speeds 3.11 miles per hour, with 30-minute interval departure | 78 |
| Figure 91. Graphic presenting the relative travel risk throughout the complete route, given rate 3.11 miles per hour, with 30-minute interval departure..... | 78 |

| | Page |
|--|------|
| Figure 93. Graphic presenting the boat capability of surviving the supply mission, given rate 6.21 miles per hour, with 30-minute interval departure..... | 79 |
| Figure 94. Graphic presenting the boat capability of surviving the supply mission, given rate 6.21 miles per hour, emphasizing the importance of travel time, with 30-minute interval departure..... | 79 |
| Figure 95. Graphic presenting the relative travel risk throughout the complete route, given rate 6.21 miles per hour, with 30-minute interval departure | 80 |
| Figure 96. Graphic presenting the boat capability of surviving the supply mission, given rate 6.21 miles per hour, emphasizing the importance of travel time, with 15-minute interval departure..... | 80 |
| Figure 97. Graphic presenting the boat capability of surviving the supply mission, given rate 9.32 miles per hour, with 30-minute interval departure..... | 80 |
| Figure 98. Graphic presenting the boat capability of surviving the supply mission, given rate 9.32 miles per hour, emphasizing the importance of travel time, with 30-minute interval departure..... | 80 |
| Figure 99. Graphic presenting the relative travel risk throughout the complete route, given rate 9.32 miles per hour, with 30-minute interval departure..... | 81 |
| Figure 100. Graphic presenting the boat capability of surviving the supply mission, given rate 9.32 miles per hour, emphasizing the importance of travel time, with 15-minute interval departure | 81 |
| Figure 101. Input Spreadsheet's Excel screenshot, given a boat width equals 1.64 feet..... | 81 |
| Figure 102. Output Spreadsheet's Excel screenshot, given a boat width equals 1.64 feet..... | 82 |
| Figure 103. Output Spreadsheet's Excel screenshot, given a boat width of 3.28 feet..... | 82 |
| Figure 104. Output Spreadsheet's Excel screenshot, given a boat width of 4.92 feet..... | 83 |
| Figure 105. Output Spreadsheet's Excel screenshot, considering a boat width of 6.56 feet..... | 83 |

| | Page |
|--|------|
| Figure 106. Graphic presenting the boat capability of surviving the supply mission, given 1.64 feet of width, with 30-minute interval departure | 84 |
| Figure 107. Graphic presenting the boat capability of surviving the supply mission, given 1.64 feet of width, emphasizing the importance of travel time, with 30-minute interval departure | 84 |
| Figure 108. Graphic presenting the relative travel risk throughout the complete route, given 1.64 feet of width, with 30-minute interval departure | 84 |
| Figure 109. Graphic presenting the boat capability of surviving the supply mission, given 1.64 feet of width, emphasizing the importance of travel time, with 15-minute interval departure | 84 |
| Figure 110. Graphic presenting the boat capability of surviving the supply mission, given 3.28 feet of width, with 30-minute interval de-parture | 85 |
| Figure 111. Graphic presenting the boat capability of surviving the supply mission, given 3.28 feet of width, emphasizing the importance of travel time, with 30-minute interval departure | 85 |
| Figure 112. Graphic presenting the relative travel risk throughout the complete route, given 3.28 feet of width, with 30-minute interval departure | 85 |
| Figure 113. Graphic presenting the boat capability of surviving the supply mission, given 3.28 feet of width, emphasizing the importance of travel time, with 15-minute interval departure | 85 |
| Figure 114. Graphic presenting the boat capability of surviving the supply mission, given 4.92 feet of width, with 30-minute interval departure | 86 |
| Figure 115. Graphic presenting the boat capability of surviving the supply mission, given 4.92 feet of width, emphasizing the importance of travel time, with 30-minute interval departure | 86 |
| Figure 116. Graphic presenting the relative travel risk throughout the complete route, given 4.92 feet of width, with 30-minute interval departure | 86 |
| Figure 117. Graphic presenting the boat capability of surviving the supply mission, given 4.92 feet of width, emphasizing the importance of travel time, with 15-minute interval departure | 86 |

| | Page |
|--|------|
| Figure 118. Graphic presenting the boat capability of surviving the supply mission, given 6.56 feet of width, with 30-minute interval departure..... | 87 |
| Figure 119. Graphic presenting the boat capability of surviving the supply mission, given 6.56 feet of width, emphasizing the importance of travel time, with 30-minute interval departure | 87 |
| Figure 120. Graphic presenting the relative travel risk throughout the complete route, given 6.56 feet of width, with 30-minute interval departure..... | 87 |
| Figure 121. Graphic presenting the boat capability of surviving the supply mission, given 6.56 feet of width, emphasizing the importance of travel time, with 15-minute interval departure | 87 |
| Figure 122. Input Spreadsheet's Excel screenshot, given a normal operational scenario..... | 89 |
| Figure 123. Theoretical network plot showing the two different scenarios | 90 |
| Figure 124. Output Spreadsheet's Excel screenshot, given a normal operational scenario..... | 90 |
| Figure 125. Input Spreadsheet's Excel screenshot, given new scenario configuration..... | 91 |
| Figure 126. Output Spreadsheet's Excel screenshot, given new scenario configuration..... | 91 |

List of Tables

| | Page |
|---|------|
| Table 1. Summary of Present Capability to Find Optimal Search Plans | 32 |
| Table 2. Comparison of the Computational Cost Required by the Algorithms..... | 42 |

STEALTHY RIVER NAVIGATION IN JUNGLE COMBAT CONDITIONS

I. Introduction

Background

One of the biggest challenges for Brazilian military logisticians is to support effective jungle warfare for both real and training operations carried out by their combined forces (Army, Navy, and Air Force), in the Amazonian region (figures 1 to 4). To support anti-guerilla actions, whether riverine or air interdiction operations, against the drug traffickers operating along the Brazil-Colombian border or to repel any aggressive international invading forces, in a defensive posture, the military supply system needs to adapt to the nature of jungle warfare (Spencer, 2004).



Figure 1. Brazilian Army commando troops during jungle operational training in Amazon rainforest, simulating a real tactical infiltration mission.



Figure 2. Embraer Super Tucano Brazilian aircraft, designed and employed in operations carried out in jungle warfare scenarios.

That means that resupply missions cannot disturb the unconventional, low-intensity, guerrilla-style operations taking place or expose the location of hidden military camps (camouflaged depots and airfields) during load/unload operations. The impact of both the challenges of a harsh environment and the hostile enemy actions against troops and logistics resources should be considered. In other words, the peculiarities of nonlinearity, reduced frontages, and short fields of observation found in the jungle combat zones need to be carefully weighed by the military logisticians while they are setting up the logistical capabilities that best fit the operations that will be performed (DA, 1993:3-26).

The North Vietnamese constantly repaired and extended these routes, in spite of American bombing. Over the elaborate trail and road network, enemy troops, fuel, and munitions flowed southward. Carried most of the way in a series of short hauls, with repeated changes of vehicles, each truck, or group of them, continually shuttled different loads over the same short stretch of road, almost always traveling by night. At various key points, troops could rest in hidden camps and supplies could be stored in carefully camouflaged depots. (Cosmas and Murray, 1986:279)



Figure 3. Brazilian amphibious commandos during riverine warfare training program.



Figure 4. Brazilian Air Force's Infantry - Special Force troop (dagger) in guerrilla tactics training.

The obstacles and opportunities inherent to jungle warfare environment, extensively evidenced in both the China-Burma-India (CBI) campaigns and Pacific Theater of Operations, during the Second World War, as well as the Vietnam War, are quite different from those encountered in other types of warfare. As a result, all aspects of jungle warfare are highly specialized – as, indeed, are those of the desert, arctic, mountain and urban varieties. Inside the forests, the phases of war, tactics, training, logistical support and administration have to be modified because of trees, which provide multiple constraints to military operations (Anderson, 1993; Cross, 2007:11). For example, in the tropical environment of canopy forests, swamps, or densely forested mountains, tanks, and heavy artillery are of little use. Similarly, trucks (figures 5 and 6), and large aircraft are inefficient in providing regular logistical support because the jungle limits the movement of personnel and material among the sites (Scott and others, 2000:91-92).



Figure 5. “In morass of mud, one jeep labors to pull out another mired up to the axles. The road passes through Hukawng-Mogaung Valley (Burma), where the jungle is thickest”. (LIFE, 1944)



Figure 6. Endless mudded conditions faced by the E Battery, 82nd Artillery, during the monsoon seasons, in the Vietnam War.

The dense vegetation and general lack of infrastructure, along with reduced visibility and engagement ranges, also make it extremely difficult to support deployed military units, or any other kind of forces on a large scale in the jungle (Asprey, 2002:838; Thompson, J., 1994). The extract below sums up why logistics in a jungle environment is challenging work.

Many of the techniques and assumptions which were accepted as valid in conventional warfare did not apply in the harsh, primitive, jungle environment and the isolated support enclaves. Even so, Vietnam is a story of remarkable logistics achievement. At no time was logistic support a constraint on a major tactical operation. This record was made despite the conditions which imposed a fantastic strain on logistics operations and which offered an enormous challenge to all logisticians. (Heiser, 1974:4)

Key Points:

- Monsoon winds alternately encourage and discourage most military operations in South and Southeast Asia.
- Geographical circumstances affect supply, maintenance, transportation, medical, and other logistical requirements at least as much as combat operations.
- Logistical problems multiply and intensify in direct proportion to the distance between support bases and supported forces.
- Jungle-covered mountains reduce the advantages of airmobile forces in open terrain.
- Parachute delivery systems and helicopters can sustain small, isolated units in jungles, but large formations need main supply routes with much greater capacities. (Collins, 1997/1998:126)

The lack of an extensive all-weather transportation network in many jungle areas makes the mission of support units more difficult (Scott and others, 2000:133-136). Transportation difficulties may dictate that maneuver units be resupplied by air, pack animals, or human portage (figures 7 to 9). For example, the rapid movement of military personnel and supplies in jungle regions is severely limited by both the dense foliage and the uneven terrain, with even helicopters being only of limited use (Heiser, 1974; O'Sullivan, 1983:67; Vongsavanh, 1981:4-5). Suitable natural gaps in the canopy are

scarce and it will almost certainly be necessary to clear a landing site by hand if aircraft are to land.



Figure 7. Filipino volunteers carry supplies into the mountains to reach 1st Cavalry Division troops in the Province of Leyte (Philippine Campaign), during the Second World War. (Anderson, 1993:24)



Figure 8. A long line of porters carry supplies along the Ho Chi Minh Trail for the North Vietnamese, during the Vietnam War. (Correll, 2005:62)



Figure 9. Native carriers bringing supplies through the jungles into the hills, in the Guadalcanal Island, during the American Pacific Offensive in 1942.

There is an extensive literature documenting the burdens faced by military commanders regarding how to conduct and support their troops into jungle areas. Below are the two passages which briefly summarize these concerns.

Jungle imposed three major limitations upon the infantry that fought there in 1941-1945. The first – lack of visibility and fields of fire – necessitated drastic revisions of small unit tactics. The second – remoteness, and obstruction to transport – not only influenced the way troops fought in battle, in ambush and on patrol, but imposed sometimes insurmountable problems on supply and the movement of heavy equipment. Getting the simplest things to the soldier could be extremely difficult: Gen Slim cited specific problems with milk, rotting cartons and rusting tins. (...) The third governing condition was the tropical climate itself; humidity combined with insect life and stagnant water to produce a bewildering variety of diseases, many of them unknown in Europe. Whilst cholera and typhus were killers, it was debilitating fevers, and above all malaria, that cut a swath through the ranks of those who fought in the jungle. (Bull, 2007:6)

The terrain was a commander's nightmare because it fragmented the deployment of large formations. On the north shore a tangled morass of large mangrove swamps slowed overland movement. Monsoon rains of eight or ten inches a day turned torpid streams into impassable rivers. There were no roads or railways, and supply lines were often native tracks, usually dirt trail a yard or so wide tramped out over the centuries through the jungle growth. Downpours quickly dissolved such footpaths into calf-deep mud that reduced soldiers to exhausted automatons stumbling over the glue-like ground. (Drea, 2008:3)

The dropping of supplies by parachute is also not very effective in the jungle. Supplies can easily fall into the hands of the enemy or land in a zone attacked by fire. Supplies can land among the trees, steep hills, or sink in the streams (figures 10 and 11). This challenge was faced by the American troops during the Papua Campaign, in the Second World War, between 23rd July 1942 and 23rd January 1943, as shown in the citation below.

The efficiency of the air arm in direct support of ground troops is strictly curtailed. The complete leaf canopy prevents pilots from seeing troops on the ground; the troops are often unable to catch more than fleeting glimpses of the planes. Pilots cannot see panels laid out on the ground; it is often impossible for the] to see panels or strips displayed in the tops

of trees. Colored smoke pots placed on the ground have been used to indicate the position of ground troops but the rapid diffusion of the, smoke renders them impractical. Smoke pots or smoke grenades to which lines are attached may be thrown into tree: There is now available a “tree top” smoke grenade which believed to be satisfactory. (DN, 1989:6)

The 1st October plan was marked by the innovation which would characterize MacArthur's leadership throughout the Pacific War: resupply by air. Once units entered the jungled mountains, resupply became a major problem. The Australian practice of relying on the strong backs of New Guineans did not solve the problem, since the bearers usually deserted when they suspected enemy presence. The Allies settled on the airdrop. Expanding its range as fast as new airfields could be constructed, the Fifth Air Force proved invaluable in overcoming the obstacles of sea distance and rugged terrain. Crates of food and supplies were pushed out the hatches of low-flying C-7 over breaks in the jungle ceiling. Though not perfect – hungry, diseased troops sometimes saw crates of food, medicine, and ammunition fall down mountainsides just out of reach – the airdrops continued and improved as aircrews gained experience. (Anderson, 1993:8)



Figure 10. “Parachute resupply in the Malayan jungle – unlike many others, this one did not get caught up in the trees”. (Cross, 2007:147)



Figure 11. Most of successful air resupply occurred in open areas instead of inside the dense wood. (Thompson, J.,1991:98)

In the case of land transport, wheeled vehicles are normally restricted to roads and wider trails, and even these may prove impassable during heavy rains (Correll, 1987/1988:65; Schweitzer and Armstrong, 1966). Sometimes, goods must be transported

by cross loading from wheeled to tracked vehicles. For instance, large wheeled vehicles move the supplies as far forward as possible, where they are transloaded to tracked vehicles that move them cross-country. In rugged terrain, the supplies may have to be further transloaded to pack animals or human supply bearers (figures 12 and 13) (Astor, 2004; Moreman, 2002:126).



Figure 12. “Muletrain”: A Chin-dit column moving through Burmese Jungle.



Figure 13. Mars Task Force mule skimmers (2d Bn., 475th Inf. Regt.) lead mules through the swift river that impeded their progress to Bhamo, Burma, 17 November 1944.

During the Burma campaign from December 1941 until August 1945, the longest campaign in which the British Army fought during the Second World War, mules were used extensively, exhaustively and often hazardously. Under the command of General Sir William Slim, the Fourteenth Army comprised men of a number of diverse nationalities – including Burmese, Chinese, Gurkhas, as well as troops from East and West Africa. In March 1942 Rangoon was lost and the Burma army began its 600-mile retreat to the Indian frontier. There was a shortage of mules, particularly the larger type of equipment-carrying animals, which made the decision to leave the roads and move through the jungle and mountain paths hard to implement. Rail and road communications were disrupted, so sick animals could not be moved and the long and arduous marches, shortage of forage, saddle galls and injuries from sharp bamboo stumps, poisonous plants and bombing raids took a heavy toll. In addition, leeches, mosquitoes and other insects made conditions very unpleasant and when the men and animals reached the frontier

monsoon conditions and the spread of tropical diseases such as malaria, dysentery and surra meant that in 1943 the Fourteenth Army suffered a total of 12,130 animal casualties. (Gardiner, 2006:76)

Mules were critical to the operation because of the versatility they added. The mules increased the hauling capability so that the soldiers could operate longer without resupply. If air drops or local food procurement failed, the Chindits would eat the mules in emergency situations. Mules also posed certain problems. They required food, got sick, injured, or died. If something happened to a mule, the equipment was either shifted to other mules and the soldiers, or left behind. (Gregory, 1987:6)

The jungle habitat is also highly characterized by an extremely hot and humid environment that adversely affects the equipment as well as the physical condition of the soldiers (Cross, 2007). The hot and damp tropical climate shortens the life of material objects and lessens the efficiency of machines. Untreated meat has to be eaten the same day that it is prepared. The stitching in clothes rots, rust appears overnight and, in monsoons, fungus grows on leather between dusk and dawn. Prickly heat rashes make the body uncomfortable, tempers short and the wearing of equipment a burden, if not an impossibility. Everything is affected in the tropics: food, matches, cigarettes, batteries, electrical equipment and munitions. For example, in the jungle, weapons tend to rust quickly, and must be cleaned and oiled more frequently than in most other areas, canvas items rot and rubber deteriorates much faster than in more temperate areas: battery life is shorter than is normal, electrical connections corrode quickly, lenses and dials become quickly fogged with internal moisture, and troops drink more water, requiring greater water purification and means of transport. The following lines exemplify these quandaries.

The war was fraught with problems from the beginning. The climate was hostile and extremely difficult to deal with. It caused health problems for many people and added to the medical service requirements. Further, the climate raised havoc

with supplies. Rain was often overwhelmingly heavy. Humidity was constantly high. Corrosion, mildew, and rot were principal problems for most all classes of supply. Mold attacked everything and, in some instances, totally destroyed the basic item. For example, combat boots and field shoes seemed to be eaten rapidly by mold. Insects and rodents were constant annoyances and caused considerable storage problems. It was necessary for the United States to construct huge quantities of covered warehousing to provide minimal supply protection. Several large depot facilities were ultimately constructed by the Services to do higher level maintenance and provide adequate supply support. Even the best of storage seemed unable to defeat the climate and the bugs. Supply losses to the environment continued through our stay in the country. (Scott and other, 2000:335)

New to jungle warfare, the division lacked even the basics for survival, prompting one military historian to label the soldiers of the 32nd the “guinea pigs” of the South Pacific. Men were issued any of the specialized clothing that later became de rigueur for the war in the South Pacific. For camouflage, their combat fatigues were hastily dyed before left Australia. In the rain and extreme humidity, the dye ran and clogged the cloth, causing men to develop horrible skin ulcers. Soldiers were forced to wade through vines, creepers, brush, dense stands of razor-sharp kunai grass, and elephant grass as high a basketball rim without the aid of machetes. They did not even have insect repellent – astonishing when one considers that they were fighting in a bug-ridden place. They were not equipped with waterproof containers either. Matches were often unusable. Quinine and vitamin pills, salt and chlorination tablets got wet and crumbled in their pants pockets. Yet, in New Guinea, the 32nd Division was asked to do the extraordinary. (Campbell, 2008:XV)

As a result, to maintain men in fighting condition, the meals served during the jungle operations include a source of fresh water, proteins and carbohydrates because there is a tremendous loss of energy in that environment (Bull, 2007:44) (figures 14 and 15). In general, beyond medications, a good supply of vitamins and energizers are carried to camp as well as a large amount of salt (Thompson, L., 1994:24). These items are required after exhausting marches or long periods without sleep. Jungle warfare is a challenge to the military logistician because of storage, transport and life time constraints of these items and after supplies.

Every one of us was sick, with malaria, diarrhea, or both, and we were all physically weak from lack of food and sleep. Back in those days, the marines didn't have "talking doctors" or psychiatrists, and we didn't know the meaning of depression. Everybody in every one of our platoons was in the same physical and mental condition. We lived on several tablespoons of captured Jap rice per day – that is, if anyone brought it out to us. Our water situation was about as bad. Not enough of it, and sometimes it wasn't available at all. (Marion, 2004:140)



Figure 14: "Battle Fatigue: a British soldier is inter-viewed by a doctor of 154th Field Ambulance, RAMC, in Burma." (Bull, 2007:5)



Figure 15: "A May 1969 photo showed a wounded United States paratrooper waiting for medical evacuation at base camp in the A Shau Valley near the Laos border in South Vietnam during the Vietnam War".

From an operational perspective, short fields of observation and fire – and thick vegetation make engaging the enemy difficult. Concerning that issue, Clausewitz made one single and important statement: "What is more, in the depth of the forest he will hardly be in a position to impress the omnipresent enemy with the superior weight of his numbers. This is without doubt one of the worst situations in which an attacker can find himself" (Clausewitz, 1984:154). The same factors reduce the effectiveness of indirect fire and make jungle combat primarily a fight between infantry forces (Asprey, 2002:844). As a result, combat in the jungle normally takes place at a close range (Bull, 2007:5) and demands a high consumption rate of munitions. Troops waste more shots

than normal to hit enemy forces. In addition, in jungle warfare, small groups of combatants often use unconventional mobile tactics, such as infiltration, ambush, raids, and guerrilla operations, and their profound knowledge of the terrain to combat a less mobile formal army. These tactics include a large variety of very aggressive surprise attacks on transportation routes, installations and fixed structures (Bull, 2007:18; DA, 2009:133; Moreman, 2002:202; Sandler, 2002:346-348). The American Army soldiers confronted this same scenario in the South-East Asian theatre of operations, during the Vietnam War, as evidenced in the passage below.

In the jungle, the advantage lies with the force that waits. A force moving at night, especially a sizeable one, cannot avoid making noise regardless of the stealth attempted. Therefore, as demonstrated by the Americans in Vietnam, ambushes are probably the most effective means of interdicting an enemy who uses the night to transport supplies or infiltrate to and from an area. (Bennett, 1993:42)

Those unconventional tactical specificities of jungle warfare, which require skills and stealth techniques, as well as nimbleness, swiftness, and readiness on the part of the jungle combatants, restrict severely the amount of provisions that they can carry, accentuating the importance of a continuous supply flow from military sources. The extract below may offer a better comprehension of these circumstances.

Each item of clothing and equipment must be considered in terms of its necessity, and serviceability in jungle environment. Lightness of weight is essential because of the difficulties of transport. Serviceability is essential, because of the problems of resupply. Every effort should be made to reduce to the minimum the amount of equipment to be used, but care should be exercised that no essential items are omitted. During training, men should be required to use only items of clothing and equipment which will be taken into combat areas; not only will this teach them to live with a minimum of essentials, but also it may indicate the non-essentiality of some things originally thought to be necessary (WD, 1944:35-36).

Under the environmental constraints as well the operational peculiarities of jungle warfare detailed above, and considering that 60% of the total Amazon rainforest is in

Brazilian territorial area, combat logistics planners should consider the use of water transport to support deployed troops during both real and training operations. That perspective emphasizes taking advantage of the rich regional natural resources – the Amazon basin – to move troops and supplies. The Brazilian Doctrine for Joint Operations recognizes the fundamental and beneficial effects of the Amazon basin for unity of effort, synchronization and integration of military operations in time and space to successful military campaigns.

The large Amazon watercourses – brooks, rivers and creeks (figures 16 and 17) – are a very important part of a transport system, especially in remote areas. Large rivers often allow small ships and large boats to penetrate several hundred miles inland (McClain and others, 2001:17). Where smaller streams branch out, a unit may establish transfer points for the transloading of cargo into smaller watercraft. A river that is normally very shallow during the dry season will be deeper during the rainy season, permitting travel by larger craft.



Figure 16. An Amazon River affluent.



Figure 17. The Amazon basin's immensity.

Because of both the large number of waterways in the area, and the characteristics of cargo-capacity, accessibility, reduced noise and exposure level, particularly during night-operations, that are provided by river vessels, water transport is the most reasonable option to sustain those deployed forces.

However, besides the multitudes of natural and artificial obstructions in watercourses (topographic features, crossings, etc), and the hydrological characteristics of rivers and streams (flooding cycle, flow rate and direction, etc), all of which affect river navigability, selecting optimal routes and schedules that reduce enemy detection (aircraft, helicopters, and unmanned aerial vehicles), while providing sufficient support to fighting forces, makes logistics to support jungle warfare operations a challenging job (figures 18 and 19).



Figure 18. Brazilian UH-60 Blackhawks over the Amazon River in operational training.



Figure 19. Brazilian Navy's fast patrol craft employed to fast deployment during riverine operations.

Problem Statement

A small deployed combat force (Special Force unit, command troop, camouflaged airfield, etc) requires time-dependent resupply in a hostile jungle environment, under the

constraints of exposure to enemy fire (aircraft, helicopters, and unmanned aerial vehicles). Planners must select among the available watercourses those whose surroundings provide stealthy navigation to the combat force location where the requested supplies are safely unloaded.

Research Focus

The context of the research is related to combat logistics (supplying under combat conditions), involving both scheduling and routing methods, in theater-level modeling.

The boundary of the research is related to supporting jungle warfare operations developed in tropical and subtropical moist broadleaf forests. This includes ones that occur in a belt around the equator such as the largest areas in the Amazon basin of South America, the Congo basin of central Africa, Indonesia, and New Guinea. This is due to the fact that these locations, between 10°N and 10°S latitude at elevations below 3,000 feet, share the following both climatic and topographic characteristics:

- a) Their annual rainfall rates of more than 3,600 milliliter (McClain and others, 2001:22), over 220 inches, as well as their temperature ranges fairly constantly between 72°F by night and 80°F by day (Louis and Draffen 2005:64), resulting in a daily flooding cycles, which change the major river attributes (speed, depth and width);
- b) Their riverine forest, whose average tree height extends from 30 feet to 180 feet (Asner and others, 2002:486), can, depending on the time of day, produce large shadow areas, wide enough to hide, completely or partially, small boats traveling on these rivers (figures 20 and 21).

This research can be extended with restrictions to military operations carried out in parts of the Afrotropic (equatorial Africa), Indomalaya (parts of the Indian subcontinent and Southeast Asia), the Neotropic (northern South America and Central Asia), Australasia (eastern Indonesia, New Guinea, northern and eastern Australia), and Oceania (the tropical islands of the Pacific Ocean), which share the same biome.



Figure 20. Riverine forest of an Amazon affluent.



Figure 21. Shadows produced by riverine forest.

Research Objectives

Develop a planning methodology that, given a time-window period (complete timeframe data), determines route and schedule (start time) to enable a water transport of provisions to a fighting unit deployed in jungle, in a way that reduces its chance of detection by aerial enemy searchers. In other words, plan the most stealthy water route from origin to destination, by taking advantage of the environment.

Theoretical Lens

The fundamental of theory of war is used as the perspective, or dominant paradigm, to guide this research. Combat logistics must to be consistent with the nature, scope and structure of war, as well the realities of the battlefield (Kress, 2002:10). This assertion is attested in the following passage.

Even if logistics affected merely the ability of armies to seize advantages in individual battles, that fact alone would make this topic crucial to the dynamics of combat. However, the effects of initiative reach far higher. Warfare is a phenomenon which can manifest itself in many different ways. There are wars of attrition, wars of maneuver, wars of position, and guerrilla wars, to name but four. If one side consistently can choose the manner of fighting in individual battles, that side is well on its way to choosing the overall character of the war. (...) Different nations prefer to wage different types of wars. Indeed, such 'preferences' are often a matter of survival. The style and tempo of combat determine what warfare will demand from the material resources of a nation, the political base of a government, the technological sophistication of an army, the diplomatic position of a state, the tactical imagination of an officer corps and the moral sensibilities of a people. One might note, in passing, that different styles of warfare go hand in hand with different styles of logistics. (Kane, 2001:9)

Although it's almost impossible to numerically assess the absolute influence of the military supply system on combat effectiveness (Dupuy, 1985:38), it definitely accounts for all activities in war that are pre-conditional to the use of the fighting forces (Haldi, 2002; Newell, 1991:100; Thorpe, 1982:67). As a result, logistics emerges as a condition possibility to conduct war. It is a tactical and strategic concern for engagement of war (Eccles, 1981:12-22; Newell, 1991:101-120; Scott and others, 2000:32; Thorpe, 1982:10-11). The purpose and scope of logistics is defined by the needs of tactics and strategy, which, by inference, connects both logistics and the theory of war, implying still that they share the same attributes (Coffin, 1993:41; Guarino, 1992).

To sum up, what is asked for logistics and what it is able to provide are profoundly influenced by the particular circumstances of a war, campaign, or battle (O’Hanlon, 2009:146-147; Rainer and others, 2003; Scott and others, 2000; Thompson, J., 1994:133-219; Tucker and Roberts, 2005:708).

Methodology

Mathematical programming is the methodology applied in this study. Search and detection theory (light and sound military doctrine) is the theoretical framework for the study.

Assumptions

Assumptions in this research are:

- a) The battlefield can be described as a network of a finite collection of nodes, which represent known locations of a deployed combat unit;
- b) Arcs represent possible paths between the nodes;
- c) Combat unit for support is known since it is derived from the basic battle plan;
- d) Support unit capacity is unlimited;
- e) The effects of weather, equipment failures, enemy interdiction on support unit, and the “fog of war” are not considered;
- f) The resupply entity doesn’t stop at any point along the path other than the unloading location. It doesn’t wait at that place after delivering its cargo. It moves in a fairly unknown manner, since it must to keep on the watercourse (network), without, exhibiting any evasive action;

- g) The key characteristics of the routes (watercourses) are risk (exposure to enemy fire level) and flow speed and depth can change independently of one another through the day but are kept constant once movement begins.

Limitations

Limitations of this study are:

- a) The dynamic nature of troop movements inside the jungle during real operations as well as the radio silence imposed by wartime orders can create difficulty in finding the precise force locations. Therefore, a precise location of all combat units is improbable;
- b) Unlimited support unit capacity is unrealistic;
- c) Combat units consume food, water, drugs, and ammunition during each time period. Quantities may vary depending on the intensity of conflict and other concerns. Therefore, the exact consumption rates under combat conditions are difficult to obtain;
- d) Chaos (chance and uncertainty) and total friction (resistance and antagonism) are essential elements of the battlefield, but aren't modeled;
- e) Watercourse features, like depth, width, and flow speed are not constant through the day, and could change slowly or abruptly depending on water system behavior;
- f) The risk level calculation which considers an omnipresent enemy exacerbates the potential sources of mission non-fulfillment creating a pessimistic scenario, which is, by definition, very improbable.

Implications

Research implications are:

- a) This research will offer a jungle campaign or theater-level model which will support military planning decisions regarding allocation of materiel, positioning of combat units, dimensioning of support installations, scheduling of sorties, and operational and tactical needs-derived decisions;
- b) This research will increase the application of mathematical programming methods in defense analysis, particularly regarding the impact of both combat and environmental restrictions in the logistics effectiveness of sustaining military operations in the jungle, in different potential scenarios;
- c) The model developed in this research can provide insights into new and distinct organizational, doctrine, training and materiel designs to deal with the specificity of supporting jungle warfare units, in both real and operational exercises;
- d) The model developed in this research will contribute relevant data concerning compatibility, feasibility and operational cost of tactical movements, intensity of combat actions, as well as estimating the readiness level of logistics systems, thus helping tacticians to develop their deployment plans.

II. Literature Review

Introduction

Theoretical perspectives and previous research findings about “minimum-exposure moving process analysis” and taking advantage of surroundings are fairly rare in military scientific literature. Excluding the large amount of studies published about the Ho Chi Minh trail, the main military approach is focused on both development and use of technologically advanced materials that provide very weak radar return or, more precisely, ones that reduce radar cross section. In other words, it’s centered on military technologies that are intended to make vehicles nearly invisible to enemy radar or other electronic detection. It’s also quite considered a sub-discipline of military tactics as well a passive electronic countermeasure (Rao and Mahulikar, 2002:629-641).

However, in most of the English lexica, the term “stealth” is perceived as an act, behavior or procedure which intends to make something imperceptible, instead of an engineering system. For instance, the Cambridge Advanced Learned Dictionary defines such expression as “the movement which is quiet and careful in order not to be seen or heard, or a secret action” (Cambridge, 2008), while the Merriam-Webster’s Collegiate Dictionary characterizes it as “the act or action of proceeding furtively, secretly, or imperceptibly” (Merriam-Webster, 2003). Keeping the same viewpoint, the Oxford Advanced Learner’s Dictionary of Current English describes the label stealth as “the fact of doing something in a quiet or secret way” (Hornby, 2007). As well, to the Chambers Dictionary, defines stealth as “a secret or unobtrusive going or passage – procedure or manner – furtiveness – (being able) to approach (an enemy) without being detected”

(Chambers, 2008). Based on the explanations presented above, it's possible to affirm that vocable stealth can be understood as the ability to move with a minimum exposure from an observer. This research employs these lexical approaches in the military supply movement analysis in jungle combat conditions.

It's common sense that the ability to operate and maneuver safely in a battlefield environment using low-detection footprint technique greatly increases the chance of success of the operational and tactic objectives. However, using shadows to conceal movement is uncommon in the current scientific military writings, being found more frequently on the Computer Science domain, especially in robotics. In the available theoretical papers analyzed, the emphasized focal point is to minimize the non-detection probability of detecting a move, instead of deceiving a fixed object (Dobbie, 1973:907).

In this research, the word "detection" is defined as "the act to gathering information pertaining to the object being sought, the sifting out of what is important information and relaying on that information in some efficient form to decision maker" (Moore, 1970:3). Therefore, it infers the existence of observer(s) capable of identifying and distinguishing, among wide-ranging physical entities, patterns which can produce behavior changes in that viewer. In the strictly military perspective, that approach implies that enemy detection can induce hostile course of actions such as damage and/or destructive acts, which would not occur if any kind of severe secret behavior was conducted. In most of the research from civilian sectors, the major concern is optimizing performance instead of minimizing impact of physical (and human) loss. The following studies identify proven benefits of concealment during operational missions.

Military Perspectival Studies

Among the rare military writings about stealth, the analysis of the Ho Chi Minh trail are the most prominent. The Ho Chi Minh trail was a logistical system ran from the Democratic Republic of Vietnam into the Republic of Vietnam, through the neighboring kingdoms of Laos and Cambodia (Thompson, 1990:134). It was not so much a single route but a network, a honeycomb of routes, passing through country that was alternately limestone karst, triplecanopy jungle, and grassland. In general, it started with the transportation arteries in North Vietnam, swung west into Laos, south to the South Vietnamese border, and at various points crossed back to the east and into South Vietnam. The Laotian part of the system continued further south into Cambodia and intersected with a network there which was known as the “Sihanouk Trail” (Vongsavanh, 1981:14).

The importance the Ho Chi Minh Trail is its stealth structural features as well as its congruent internal management. Its singular characteristics included the use of “camouflaged vehicles” (figure 22), the “invisible roads” dug out of riverbeds during the dry season and used at night so as not to leave convoy tread marks, “submarine bridges” built just under the waterline of a river to be invisible from the air, over which convoys crossed with foot guides, as well as the evolution of the trail from a footpath (figure 23) to an eventual logistical highway designed with truck stops.

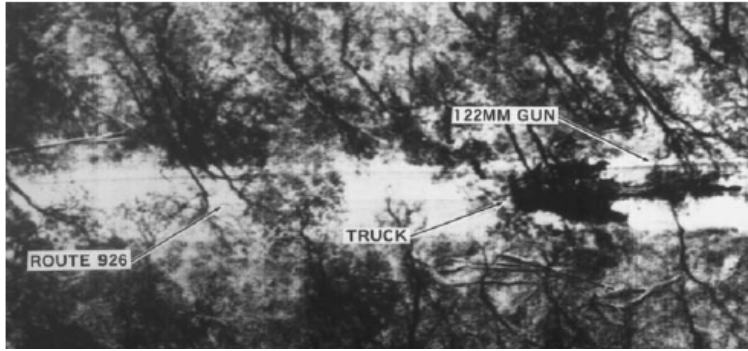

Figure 22. A camouflaged truck towing a 122mm gun in February 1973 (Nalty, 2005:290).



Figure 23. Bicycles laden with supplies in the Ho Chi Minh Trail.

The routes consisted mostly of small trails, practically undetectable from the air, for personnel movement and roads for vehicles. Personnel generally walked or pushed bikes along narrow foot-paths (figures 24 and 25). These personnel were both porters carrying war supplies and soldiers going south to fight. The network (for both vehicle and foot traffic), on the other hand, consisted of the trails, themselves connected by a series of small rest-points, larger storage sites, and a few major base areas manned on a permanent basis (figure 25). The network, therefore, needed not only soldiers to operate the routes, but also personnel to feed and support the workers.

In terms of furtiveness and unobtrusiveness aspects, the Ho Chi Minh Trail is perceived by the historians as the most secret military logistics system in the history of armed conflict. The following passage confirms the success of the Ho Chi Minh trail enterprise.

In the world of logistics, there are a few brand names to match of the Ho Chi Minh Trail, the secret, shifting, piecemeal network of jungle roadways that helped the North win the Vietnam War. From the air the Ho Chi Minh was impossible to be identified and although the United States Air Force tried to destroy this vital supply line by heavy bombing, they were unable to stop the constant flow of men and logistical supplies. The miracle of the Ho Chi Minh Trail “logistic highway”

was that it enabled the “impossible” to be accomplished. A military victory is not determined by how many nuclear weapons can be built, but by how much necessary materiel can be manufactured and delivered to the battlefield. The Ho Chi Minh Trail enabled the steady, and almost uninterrupted, flow of logistics supplies to be moved to where it was needed to ultimately defeat the enemy. (Taylor, 2007:1-7)

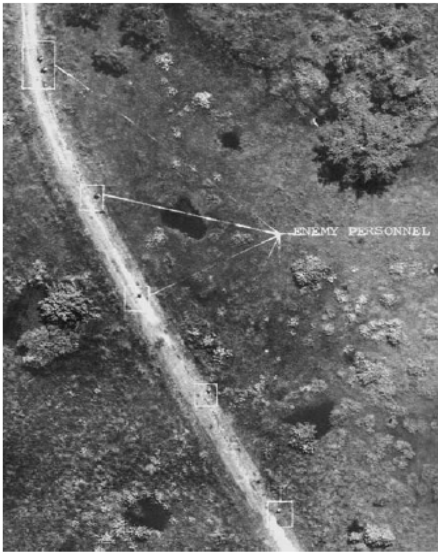

Figure 24. “A group of walking North Vietnamese on the Ho Chi Minh trail” (Nalty, 2005:284).

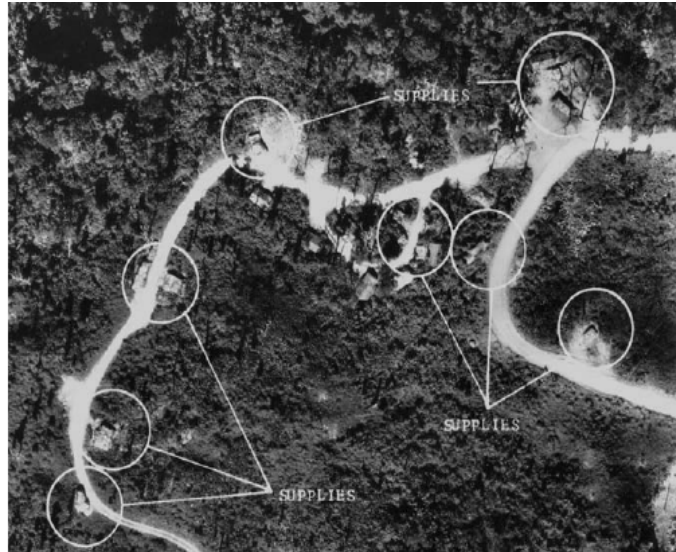

Figure 25. A Serial of camouflaged supply depots set up through-out the Ho Chi Minh trail. (Nalty, 2005:285).

Civilian Perspectival Studies

On the first civilian essay studied, a group of researchers from the University of Southern California developed an algorithm using the stealth strategy to improve performance tasks in multi-robot assignments. The key idea was to reduce both resource conflict and physical interference created among the machines, since beyond some critical limit, any additional robot decreases overall performance. Keeping as low a profile as possible, the robots could carry out their tasks in the presence of single or multiple observers, which included locating, corralling, surrounding, and navigation

(figures 26 and 27). In that study the researchers assumed an unlimited omnidirectional sensing observer. The robots carry out their traverses one at a time, and the environment consists of objects that can occlude the robots from the observer's sensors. Also, the team initially had no map of the environment but the positions of the observer and the goal are known.

According to the final experimental results, conducted both in simulation and in a real outdoor environment, the researchers demonstrated the algorithm's versatility in taking advantage of an environment that changes between robot traverses. Their outcomes also revealed that surrounding configurations allow the robustness of the approach to be evaluated in terms of low-visibility path selection, advantage of sharing information to reduce cumulative visibility, repeatability, and reactivity to a changing environment. The method can be briefly summarized in the following statements.

In our approach, the robots carry out their traverses one at a time, sequentially, and generate an occupancy grid representation of the environment *en route*. The occupancy grid is modeled by potential fields, along with task specific information such as observer and goal position. The combination of the fields forms an abstract view of the environment from which navigation waypoints are extracted. To take advantage of multiplicity, each robot commencing a traverse is provided with the occupancy grid and filtered path information from the previous robot. The filtered path is a waypoint list generated from events that occurred along the robot's path. The successor robot uses this information to make decisions about waypoint selection and overwrites the provided occupancy grid with its ego-centric sensor data. By sharing information, each robot follows a lower-visibility path than its predecessor, and in the case of static environments, the paths are traversed more efficiently. (Tews and others, 2004)

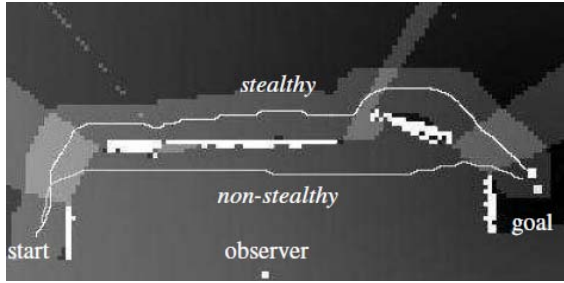

Figure 26. “An example of stealthy and non-stealthy traverses shown on the global potential field. The irregular white objects are the barricades. Dark areas represent shadows behind the barricades and therefore attractive locations for the robot. The grey area surrounding the stealthy path is the accumulated effect of a local high-valued potential field that is positioned at the robot’s location during the traverse to prevent waypoints being selected too close to it.” (Tews and others, 2004)

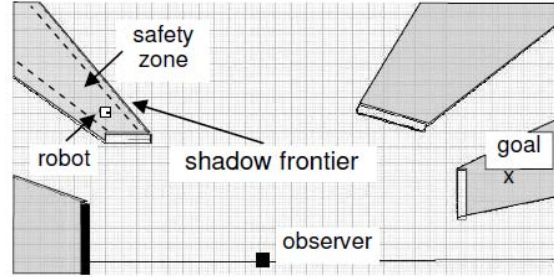

Figure 27. “The shadow regions are cast behind objects from the observer’s position. Safety zones are regions inside shadows for the robot to manoeuvre without being exposed by accidentally overrunning a frontier” (Tews and others, 2004).

Under the same label, another group of researchers from the University of Southern California studied stealthy traverses using artificial intelligence devices. Robot is tasked with moving from one location to another while remaining hidden from an observer at a known location. Since the researchers assume that robots have no priori model of the environment, a stealthy transverse behavior makes opportunistic use of terrain features to hide from the observer (figures 28 and 29). To perform that experiment, the researchers developed and employed a behavior-based algorithm which combines a number of well known techniques, such as potential fields, ray-tracing and connected components (Birgersson and others, 2003).

According to their research, the robot used a pair of two 2-dimensional internal maps to represent the world: one map describes the location of obstacles, while the other describes the world's observability (i.e., which areas can or cannot be seen by the

observer). These maps induced an artificial potential field that was used to guide the machines towards the goal, away from obstacles, and towards unobservable regions. These experiments show a clear improvement in the stealthiness of the robot, when evaluated in both real and simulated experiments, comparing it against a regular goal-seeking/obstacle-avoidance behavior. Although the algorithm does still have some weaknesses, due to resulting primarily from local minima in the potential fields, the experiments confirmed that the algorithm does indeed produce stealthy behavior.

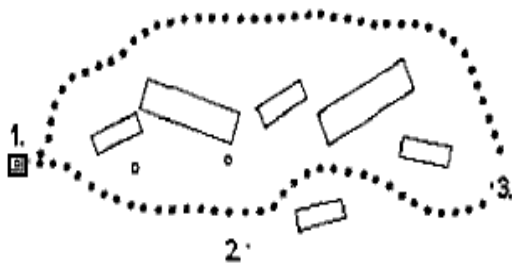

Figure 28. This picture above shows a real robot movement which applied the sneaky behavior. The point number 1 represents the start position; an observer is placed on the point 2; and the point 3 denotes the goal spot.

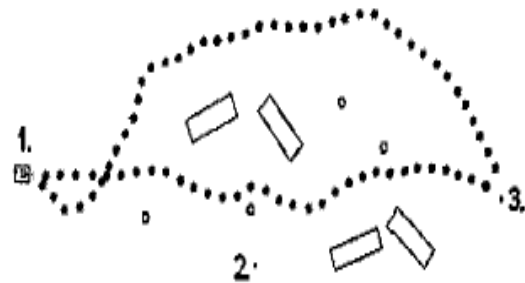

Figure 29. Above, another layout presents a path following by a stealth behavior-based robot. As the figure 26, points 1, 2 and 3 designate the start position, observer location and target point, respectively.

According to Ravela and others, the motivation for using terrain features:

(...) lies in the need for robust stealth navigation, i.e. to be able to react to uncertainty in the environment arising from inaccurate terrain maps, inaccurate sensory modalities such as odometry or to react to a dynamic environment where the target is moving. (Ravela, 1994:1093)

A civilian/military application of low-visibility path can be found on the study carried out by three researchers, Teng, DeMenthon, and Davis, all of them from the Department of Computer Science of the University of Maryland Institute for Advanced

Computer Studies. In their writings they described a method for solving visibility-based path planning problems over natural terrain using massively parallel hypercube machines (Teng and others, 1993). These problems arose in the development of both autonomous and teleoperated systems for vehicle navigation in a battlefield scenario, in which a typical example is to find a path that is hidden from moving adversaries. According to their paper, that kind of problem, i.e. path planning with moving obstacles, can be generalized as a time-varying constrained path planning problem, and it's proven to be computationally hard (Reif and Sharir, 1985). Their summarized problem is presented in the passage below (see figure 30).

Given a digital terrain map with elevation data at each grid cell, and information about a friendly agent and adversary agents moving on the ground, we want to find a path for the friendly agent from its current position to a final goal such that the movement of the friendly agent is hidden from the adversaries by taking advantage of the terrain. We refer to this property as *safety*. (Teng and others, 1993)

It is important to emphasize that visibility constraints are potentially harder than obstacle constraints since their sizes and distributions can change in time with little coherence, nearly randomly. Also, the analysis of visibility requires intensive computation, showing that their problem is potentially harder than path planning under moving obstacle constraints. However, by transforming these problems to a discretized formalism, many basic computations can be arranged in a regular pattern, and thus could be done in parallel efficiently. Therefore, the researchers decided to combine, simultaneously, the three categories of path planning (path planning with moving obstacles, for terrain navigation, and visibility analysis on terrain), with digital

approximation techniques on a powerful parallel machine which could solve realistic problems in an acceptable amount of time.

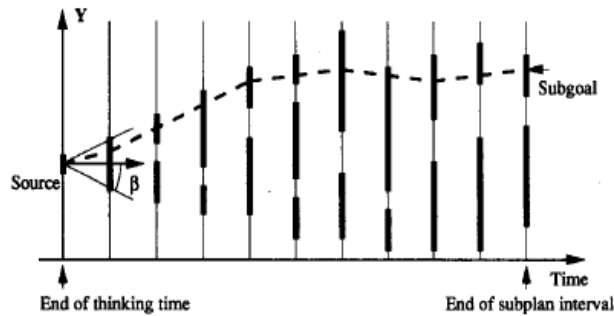

Figure 30. “Finding a path through the Safety-Reachable (RS) corridor; thick vertical line segments show the RS regions and the dashed line is an example of a valid path, in which the angle β represents the speed constraint” (Teng and others, 1993).

Although that kind of problem has been proved to be hard, it is nevertheless a very important problem. Researchers have developed algorithms to plan the best path under different assumptions and approximations. For example, an algorithm proposed by researchers Kamal Kant and Steven Zucker used a path-velocity decomposition approach that first finds a minimum length path among the static obstacles and then determines the speed along the path to avoid collision with the moving obstacles (Kant and Zucker, 1986). Theoretically, this same approach can be employed on the current jungle warfare supply problem, in which the “path length” is replaced by “risk level” or “travel survivability potential”.

When discussing detection actions, both in military as well in civilian prospect, it becomes important to refer to the search theory foundations. This knowledge provides the most effective quest techniques when developing and sustaining effectual hide-out behavior. In consequence, the tactical analysis conducted in selecting stealthy routes also

involves comprehension of the main search theory concepts (Morse and Kimball, 1998:86).

As stated in many Search, Detection and Damage Assessment's literature sources, the efficiency of search is measured in terms of the ability of the observer to identify the aim (Przemieniecki, 2000:261; Washburn and Kress, 2009:133; Zehna, 2005:125, 271). This will be altered by the speed of the searcher as well as the target visibility. Rapid search or poor visibility reduces the likelihood of the target being identified. A slow search will reduce the area that can be covered in the time available.

The critical aspects of a search problem are concerned with the nature of the target in space and time, and the method and efficiency of search. It is convenient to consider the target in dimensional terms as well to be described in terms of knowledge of its movement patterns (Zehna, 2005:258). Also, the target is assumed to have a particular probability of being in a specific location, which is critical to the eventual search methods adopted. For example, during war campaigns, ground supply convoys are more likely to be found along the existing roads in theatre of operations instead of any location far away from military service camps. From the same prospect, the detection function also takes into account the observer attributes, such as its velocity, altitude, available frequency search time, as well as the search models (exhaustive, random, and inverse cube law) chosen by camp commanders (Przemieniecki, 2000:269).

Therefore many concerns and assumptions arise about the target, such as number, position, movement, as well the effectiveness of the searcher using different quest strategies. In general, the goal is to increase the probability of "success" by choosing the best plan within the limits of time or resources. In Table 1, it's possible to identify the

major search strategy attributes which need to be weighed for military planners. In this specific study, combat logisticians conceive their war supply plan of action before performing on the field of battle (Stone, 1975).

Table 1. Summary of Present Capability to Find Optimal Search Plans (Stone, 1975)

| Search Effort | Stationary | Moving | |
|---|--|--|-------------------------------------|
| | | Discrete Time | Continuous Time |
| Short Range Infinitely Divisible | Uniformly solvable for concave detection functions | Solvable with exponential detection function | Necessary and sufficient conditions |
| Discrete Effort | Solvable in principle | Necessary but not sufficient conditions | Little or no progress |
| Constraints on Search | Solvable only in special situations | Some progress | Little or no progress |
| Long Range | Some approximate solutions | Little or no progress | Little or no progress |

Comparing both the content presented in chapter I which highlighted that jungle warfare is founded on resistance strategy “trading space for time” (Epstein 1985:14). The research findings above infer that there is not an optimal search plan for the long range search effort. That conclusion benefits the defender since the aggressor must spend their human and materiel resources, which are limited by nature to locate their opponent without any expectation of an end result. Therefore, from the jungle combat logistics standpoint, timely supply isn’t a cut-off constraint, and a reasonable time-window will always exist.

Under the detectability problems, the Department of Industrial Engineering’s researchers from the Seoul National University applied the theory of search concepts to

improve the single-searcher path-constrained discrete-time Markovian-target search problem solution. They proposed an algorithm that uses an approximate non-detection probability of a search path, referred to as the *depth-l* approximation, which is computed from the conditional probability reflecting the search history over the time windows of a predetermined length, l . The problem then is formulated as a shortest path problem on an acyclic layered network whose number of layers is of the order of search duration T . The objective is to find a searcher's path that minimizes the non-detection probability, i.e. the probability that the target survives the search.

A single target moves among a finite set of cells $S = \{1; 2; \dots; C\}$ over the discrete time periods $t = \{1; 2; \dots; T\}$. At the beginning of each time period, it moves from a cell, say i , to a cell, say j , of its neighbors, $N(i)$, with transition probability p_{ij} . We adopt the hexagon cells (see figures 29 and 30) instead of square cells which appear to enhance the model's applicability. In this case, given a cell, the neighbors of the cell are defined to be the 6 adjacent cells and the cell itself. Hence the number of neighbor of a cell $v = 7$ except the case when the cell is near to the search area boundary. A single searcher examines one cell during each time period. If the target happens to be in the same cell, say i , the searcher detects it with probability $q_i = (1 - e^{-\alpha_i})$ for some $\alpha_i > 0$. Our goal is to find a path of the searcher, represented by the cells it visits over the time periods, $i_1; i_2; \dots; i_T$ that minimizes the non-detection probability. (...) When a search path is fixed, the target's non-detection probability can be computed by conditioning on the target's location over the search periods. The difficulty of the problem lies in that the number of the possible search paths grows exponentially as T or C increases, while the enumeration is unavoidable in an exact method due to the intractability of the problem. To cope with the difficulty, we propose a heuristic minimizing an approximate, instead of exact, non-detection probability of a path. (Hong and others, 2009:352)

Though the main dissimilarity between the previous surveys are associated to a single searcher and its behavior, omnidirectional sensing stationary conduct and target seeker attitude, pursue the non-sighting probability minimization while the (single) target keeps moving (figures 31 and 32).

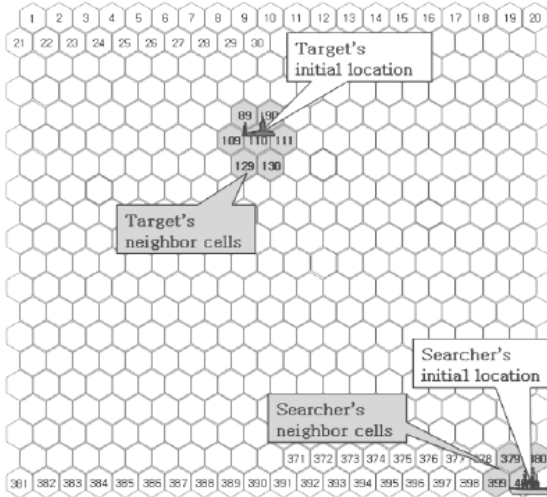

Figure 31. A search area with 400 hexagons cells (Hong and others, 2009:353).

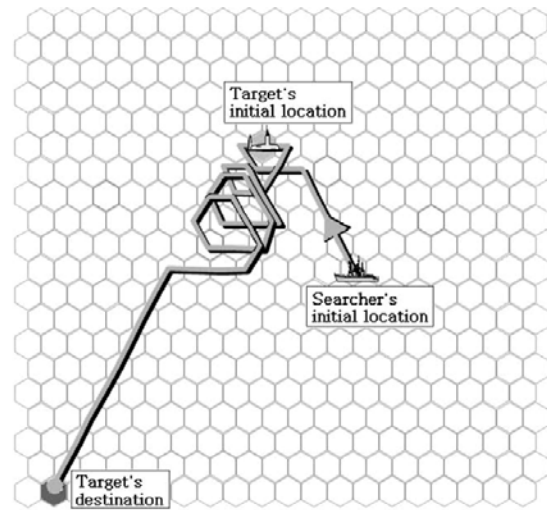

Figure 32. An example of heuristic optimal path (Hong and others, 2009:363).

Synthesis

As previously mentioned, the number of academic papers, empirical analysis as well as virtual experiments, using modeling and simulations approaches, regarding stealthy conduct are small compared to its technological research. However, among these extracts, important and fundamental insights were gathered that built the theoretical perspective of optimal supply technique in jungle combat conditions.

The first conclusion from this review confirms the logical and rational importance of environmental features on the shadow making process, as well as its practical applicability in both military and civilian sectors. Further, the nonmilitary research results demonstrate a powerful area of study, in which unobtrusive and sneaky movements enable systems achieving a high performance level when the mutual sense of presence inhibits total effectiveness.

The second inference is related to the usefulness of setting up an omnidirectional sensing observer assumption. This point of view suggests a conservative posture, and will guarantee that the final research outcomes will provide the worst possible operational situation for provision action plans on the battlefield. Consequently, camp commanders as well as their logistic planners identify their maximum loss in terms of materiel, personal and equipment which improves both their logistics and tactical decisions and their mission feasibility. In other words, based on “calculated risk” they match support plan with combat actions (Eccles, 1981:80).

The third upshot refers to the evidenced complexity and circuitousness involved in developing an efficient search strategy, which essentially means to attain the intended objective without wasting resources (time, effort and expense). The vast number of options, in addition to the occasional complex relationship among mathematical variables can produce a diversity of outcomes, suggests a prudent and careful research posture in order to avoid setting out for tortuous and endless paths.

III. Methodology

Introduction

A practical and reasonable way to carry out a resupply mission with combat units and provides low-visibility to aerial observers while reducing the risk of enemy detection during the travel is to take advantage of the surroundings, especially the shadows provided by large and bulky tropical riverine flora. Choosing routes that offer large dark areas upon the river surface, so the boat can travel the watercourse network safely improves the chance of survivability.

Taking advantage of the surprise effect, of flexibility and adaptability, peculiar attributes of irregular warfare operations, are needed for jungle warriors. It becomes imperative that they also are shared by jungle combat logisticians (Gregory, 1987). In order to meet the demands imposed by forces fighting in a characteristically nonlinear dynamic battlefield, the logistics domain must go through a commensurable transformation; maybe a large “paradigm shift” in its attitude at the tactical level of war (Asprey, 2002; Pinkston, 1996). For example, instead of transporting a large quantity of provisions, they should plan shorter but regular loadings, coherent with the logical nature of a high mobile style of war, which eliminates large static stockpiling.

Similarly, transportation cost or delivery time precision (punctuality) are not the major metrics to measure the success of a military logistics operation in a jungle scenario. The basis of successful guerrilla combat is the resistance strategy and offensive action combined with surprise. The jungle combatants manage the time element (DA, 2009:10;

Trinquier, 2006:70). Rather, the ability to load the entire cargo in response to operational needs is much more important.

Regarding the stealth efficiency of each path, the darkness magnitude, depends directly on the source of light as well the shadow-casting object. In this study, the former is the sun, while the latter is the botanic system bordering the watercourses. Considering that the intensity of sun radiation is a function of the solar direction relative to the local plane of the earth's surface at that instant, and also taking into account that variables such as solar azimuth and solar altitude angles change continuously throughout the day, solar radiation needs to be continuously updated while the boat is moving on the network. To make simpler computations, the solar declination angle may be assumed constant and is calculated only once per day.

Given a triad of information date/time/location as well a structured network (source, destination, path attributes, and existing connections) the best movement of an ship inside a temporal window may be computed through three basic and fundamental steps:

First, set up a solar position algorithm capable to provide shadow lengths based on actual move position over time. The position of any place upon the surface of the Earth may be at once determined when its latitude and longitude are known (Lawson, 2008:6). The former gives its distance, north or south, from the equator; the latter, its distance east or west of a certain point. In England, the point agreed upon is Greenwich. In common usage, "latitude" refers to geodetic or geographic latitude and is the angle between the equatorial plane and the direction of gravity at any point to the reference ellipsoid, which approximates the shape of earth to account for flattening of the poles and

bulging of the equator. This value usually differs from the geocentric latitude, which, as the name implies, is the angle, at the center of the earth, between the plane of the equator and a line drawn from the observer to that center. The line evidently does not coincide with the direction of gravity, since the earth is not spherical (Duffett-Smith, 1988). Geocentric latitude is employed in astronomical calculations, since it relates to the moon and eclipses, in which it becomes necessary to reduce observations to the center of the earth (Young, 1902). To simplify the calculations, the Ptolemaic view of the sun's motion around the earth is used. In other words the site is fixed and is the centre of origin.

Second, determine the risk measure of effectiveness between each node, through the travel time. This information is obtained from the study of cinematic behavior of the sun through the sky, using the astronomical algorithm defined in the first step, as well as the mathematical elemental procedures comparing both the local path azimuth and the local solar azimuth, at each particular time. Using trigonometric identities with solar and earthly attributes, it's possible to figure out the available shadow, on each path at any period of time. Therefore, once the boat leaves its dock, which is assumed fix on the depot location, the total travel risk level will depend exclusively on the time departure, as well as the path it had taken. Assuming that after accessing a route the move can't return all possible outcomes need to be previously tested in order to define the potential optimal route, if that is possible and really exists. Route identification is performed employing an algorithm that is capable of minimizing the formerly defined success mission attributes called exposure to enemy fire level, or simply, risk level.

Finally, set up a graph algorithm capable to work on network flow problems, particularly one distance-time parameters minimization in route optimization studies.

Applying the elemental principle of isomorphism – preservation of structural logic – it's possible to appropriately shift the above-mentioned variables and solve the travel risk assessment quandary proposed in this research.

Manual Solar Position Calculation Model

The solar position in the sky relative to a location on the surface of the Earth can be specified by two angles: the solar altitude and the solar azimuth (Iqbal, 1983) (figure 33). The former is the angle between the sun's position and the horizontal plane of the earth's surface. At sunset/sunrise the altitude is 0 and is 90 degrees when the sun is at the little zenith. The latter specifies the angle between the line from the observer to the sun projected on the ground and the line from the observer due south. A positive azimuth angle generally indicates the sun is east of south, and a negative azimuth angle generally indicates the sun is west of south (Calow, 1999:137).

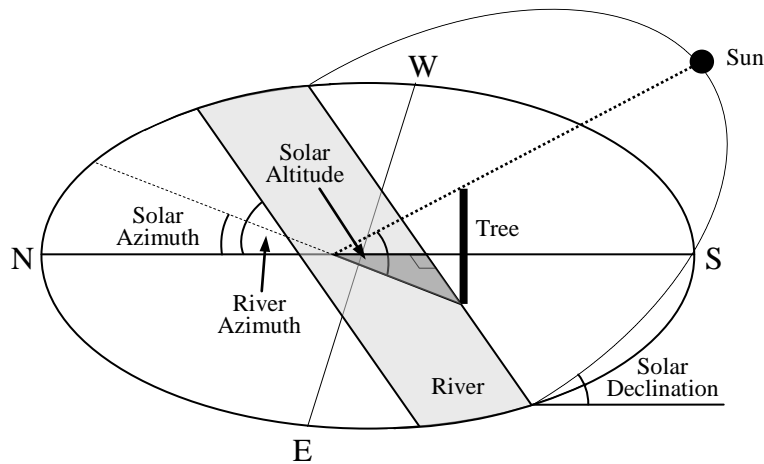

Figure 33. Major attributes used to calculate the risk on each path (river).

The astronomical scientific literature contains many fast algorithms for solar position calculation. They require a small computation effort, although their uncertainties

are greater than 0.01° in solar zenith and azimuth angle calculations; further, some of them are only valid for a specific number of years. For example, Michalsky's calculations are limited to the period from 1950 to 2050 with uncertainty greater than $\pm 0.01^\circ$ (Michalsky, 1988), and the calculations of Blanco-Muriel and others are restricted to the period from 1999 to 2015 with maximal error of 0.008° (Blanco-Muriel and others, 2001). Some algorithms like the Spencer formula and the Pitman and Vant-Hull algorithm, cannot reduce the error more than 0.25° and 0.02° respectively (Reda and Andreas, 2003), but also present the ecliptic sun coordinates based exclusively on its declination and equation of time (Blanco-Muriel and others, 2001), which require additional reckoning to obtain both the solar azimuth and altitude angles.

At this time, the most precise solar position calculator is National Renewable Energy Laboratory Solar Position Algorithms (NREL's – SPA), proposed by Ibrahim Reda and Afshin Andreas in 2003. It calculates the solar zenith and azimuth angle with uncertainties smaller than 0.0003° , in the range from 0° and 90° , on a long time period (2,000B.C.-6,000A.C). Nevertheless, it involves a large amount of calculation (Grena, 2008), requiring the use of tables to calculate heliocentric latitude, longitude and radius vector on each Lagrangian point, and also “breaks” some standards to accommodate for solar radiation applications. For instance, the algorithm estimates the azimuth angle measuring eastward from north instead of westward from south; also it computes the observer's geographical longitude considering negative west, or positive east from Greenwich, contrary to current astronomical conventions (Reda and Andreas, 2003:1).

Recently, Roberto Grena, a researcher from the Centro Ricerche Casaccia in Rome, suggested an algorithm that allows computing the sun position very accurately,

with a maximal error of 0.0027° . In his work, the researcher considered the main effects can affect the solar position like the moon perturbation, nutation, difference between topocentric and geocentric coordinates, refraction disturbance effect, and also introduced some empirical corrections in the heliocentric longitude calculation to sum up all the other small perturbations too complex to be considered one by one (Grena, 2008). His method is quite adapted to the period 2003–2023, and strongly reducing the amount of calculations needed, especially the number of trigonometric functions, whether compared to the previous mathematical procedures.

Another alternative option as a step-by-step problem-solving procedure to track accurately the solar position with small computational effort is to employ a Carruthers-Szokolay composite algorithm. The azimuth and altitude of the sun were calculated using formulae first proposed by Spencer (1965), then refined by Szokolay (1996). The value for solar declination was determined using formulae proposed by David Carruthers (1990). All angles are in radians which is a common requirement of most implementations of trigonometric functions in spreadsheets.

Although the time of calculation depends on the machine and on the programming language used, an approximate comparison can be found by simply comparing the number of times each algorithm calls a trigonometric function, both direct and inverse, since such functions usually have a computational cost much bigger than that of all the other operations (Grena, 2008).

A synopsis of solar calculation methods are presented in Table 2. With respect to accuracy and timely answer attributes, the Reda and Andreas algorithm was chosen for

both its acceptable computational tractability in the VBA Excel environment, and its more than satisfactory precision in providing solar location in the sky.

Table 2. Comparison of the Computational Cost Required by the Algorithms
(Grena, 2008)

| Algorithm | Additions and subtractions | Products and divisions | Direct trigonometric functions | Inverse trigonometric functions |
|--------------------------|----------------------------|------------------------|--------------------------------|---------------------------------|
| Blanco-Muriel and others | 35 | 36 | 16 | 4 |
| Michalsky | 28 | 25 | 19 | 4 |
| Grena | 52 | 54 | 21 | 4 |
| Carruthers and others | 26 | 35 | 16 | 2 |
| Reda and Andreas | >1000 | >1300 | >300 | 7 |

Manual Risk and Vulnerability Calculation Model

In non-technical contexts, the word “risk” refers to situations in which it’s possible but not certain that some undesirable event will occur. In technical contexts, on the other hand, this term presents several more differentiated meanings, as it can be seen below (Hansson, 2002:1):

- a) An unwanted event which may or may not occur;
- b) The cause of an unwanted event which may or may not occur;
- c) The probability of an unwanted event which may or may not occur;
- d) The statistical expectation value of an unwanted event which may or may not occur;
- e) The fact that a decision is made under conditions of known probabilities.

Although most of the above-mentioned meanings of “risk” have been found in the philosophical literature, the more informal definition, namely as “the probability of an undesirable event may or may not occur”, was chosen to be employed in this research,

since it's consistent with most of the current English lexis. The Cambridge International Dictionary of English, for example, defines risk as “the possibility of something bad happening” (Procter, 2001), while the Compact Oxford English Dictionary opted for “the possibility that something unpleasant will happen” (Soanes, 2008). Following the same sense, the United States Department of Defense defines risk as “the probability and severity of loss linked to hazards” (Camm and Greefield, 2005:11).

Considering that the probabilistic approach, i.e. existence of random outcomes, translates the essence of risk idea, its logical-mathematical formalization presents itself as the better phenomenon description, well-expressed in the following statement.

“Let A be an event belonging to the field of event A of an experiment. If event A occurred n_A times while we repeated the experiments n times, then n_A is called the frequency, and $\frac{n_A}{n} = h_A$ is called the relative frequency of the event A . The relative frequency satisfies certain properties which can be used to built up an axiomatic definition of the notion of the probability $P(A)$ of event A in the field of events A . A real function P defined on the field of events is called a probability, if it satisfies the following properties” (Bronshtein and others, 2007:748-749).

a) For every event $A \in A$ we have:

$$0 \leq P(A) \leq 1 \text{ and } 0 \leq h_A \leq 1 \quad (1)$$

b) For the impossible event O and the certain event I , we have:

$$P(O) = 0, P(I) = 1, \text{ and } h_O = 0, h_I = 1 \quad (2)$$

c) If the events $A_i \in A$ ($i = 1, 2, 3, \dots$) are finite or countably many mutually exclusive events ($A_i A_k = O$ for $i \neq k$), then:

$$P(A_1 + A_2 + A_3 + \dots) = P(A_1) + P(A_2) + P(A_3) \dots, \text{ and}$$

$$h_{A_1+A_2+A_3\dots} = h_{A_1} + h_{A_2} + h_{A_3} + \dots \quad (3)$$

Therefore, based on the above-mentioned theory of probability axioms, likewise the theoretical construction derived from literature review, “risk level” calculation is found on the relationship between the boat width (“simple outcome”) and the perpendicularly projected shadow length to the path azimuth (“field of events”), which represents the total linear shadow capable to cover the move during travel time on each path (figure 34). Formally:

$$\text{Risk Level} = \frac{\text{Boat width}}{\text{Perpendicularly projected shadow length to the path azimuth}} \quad (4)$$

Azimuth, in the military and land-navigation contexts, can be defined as “the horizontal angle of the observer's bearing in surveying, measured clockwise from a referent direction, as from the north, or from a referent celestial body, usually Polaris” (Harcourt, 2006). It can be computed using the following equation:

$$Az_{ij} = \text{Acos} \left(\frac{\sin(\theta_j) - \sin(\theta_i) \times \cos(S_{ij})}{\sin(S_{ij}) \times \cos(\theta_i)} \right) \quad (5)$$

If $\sin(\rho_j - \rho_i) < 0$, then Path Azimuth = Az_{ij}

If $\sin(\rho_j - \rho_i) > 0$, then Path Azimuth = $2\pi - Az_{ij}$

Where:

- a) Az_{ij} : Path Azimuth.
- b) θ_i : latitude of start point.
- c) θ_j : latitude of end point.

- d) ρ_i : longitude of start point.
- e) ρ_j : longitude of end point.
- f) S_{ij} : distance between start and end points.

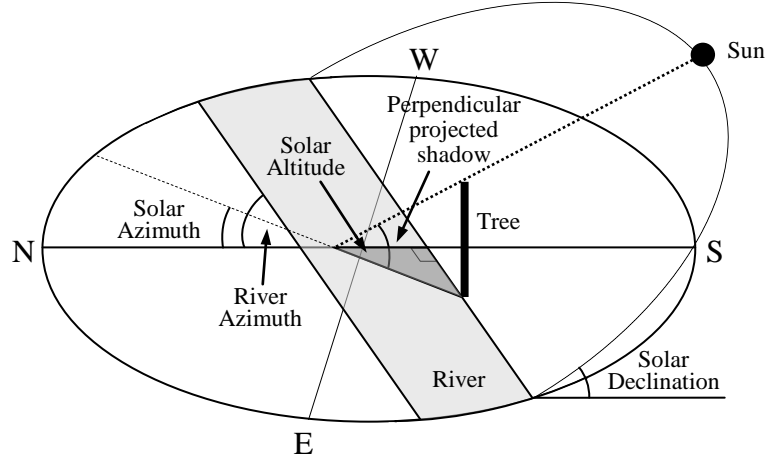

Figure 34. The major attributes to risk level calculation on each path.

Combining solar altitude, solar azimuth and path (river) azimuth equations it's possible to define the risk level calculation.

$$risk\ level = \lambda_{ijt} = \frac{\varphi}{\frac{\sin(\delta_{ij}) \times \omega_{ij}}{\tan(\varepsilon_{ijt})}} \quad (6)$$

Where:

- a) φ : boat width.
- b) δ_{ij} : difference between solar azimuth (ϕ) and path azimuth (η).
- c) ω_{ij} : Riverine forest height between points i and j .
- d) ε_{ijt} : Solar Altitude between points i and j , at time t .

It's important to emphasize that δ_{ij} value depend on the quarter-circle in which each azimuth is found, since the risk is established in terms of the perpendicular projected shadow.

a) Both Solar and Path Azimuths are in first quadrant:

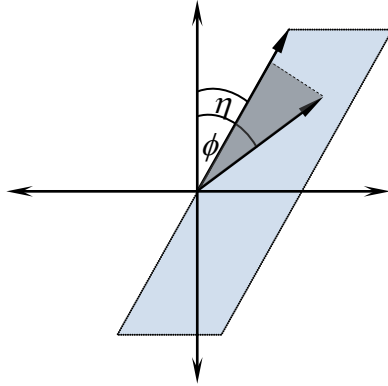

Figure 35: If $\phi > \eta$ then $\delta_{ij} = \phi - \eta$ (7)

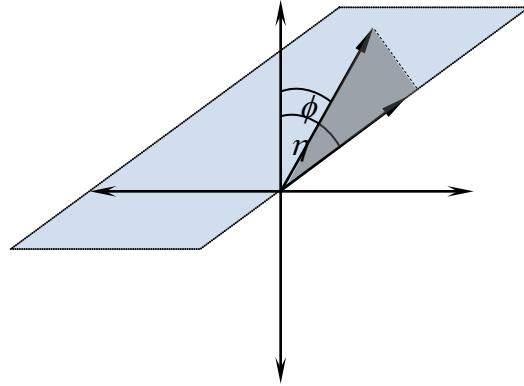

Figure 36: If $\eta > \phi$ then $\delta_{ij} = \eta - \phi$ (8)

b) Path Azimuth is in the first quadrant and Solar Azimuth is in the second one:

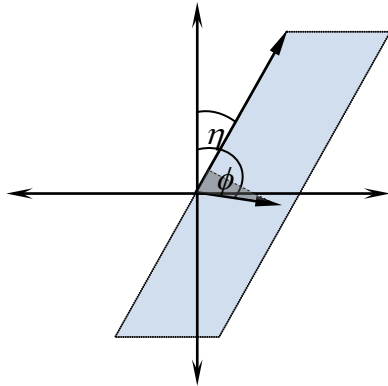

Figure 37: If $(\phi - \frac{\pi}{2}) < \eta$ then $\delta_{ij} = \phi - \eta$ (9)

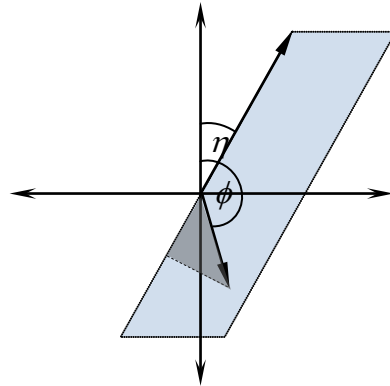

Figure 38: If $(\phi - \frac{\pi}{2}) > \eta$ then $\delta_{ij} = \pi - \phi + \eta$ (10)

c) Path Azimuth is in the first quadrant and Solar Azimuth is in the third one:

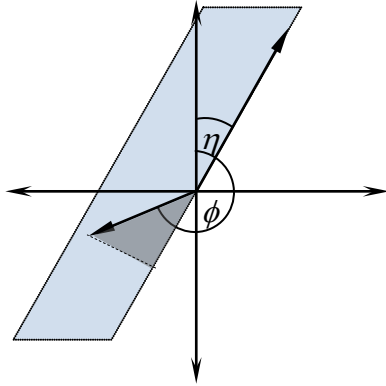

Figure 39: If $(\phi - \pi) > \eta$ then
 $\delta_{ij} = \phi - \pi - \eta$ (11)

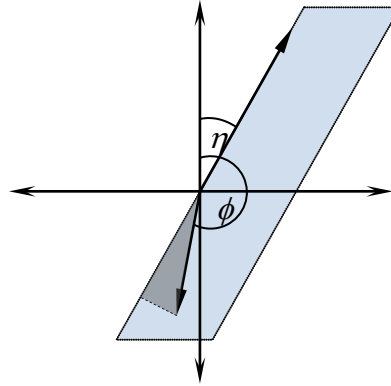

Figure 40: If $(\phi - \pi) < \eta$ then
 $\delta_{ij} = \phi - (\eta - \pi)$ (12)

d) Path Azimuth is in the first quadrant and Solar Azimuth is in the fourth one:

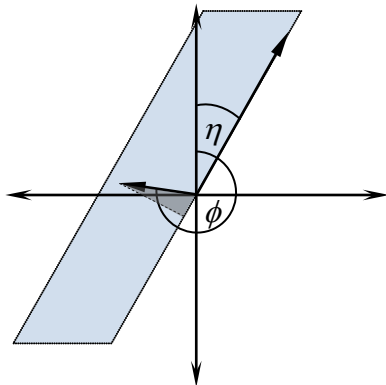

Figure 41: If $(\phi - \frac{3\pi}{2}) < \eta$ then
 $\delta_{ij} = \phi - \pi - \eta$ (13)

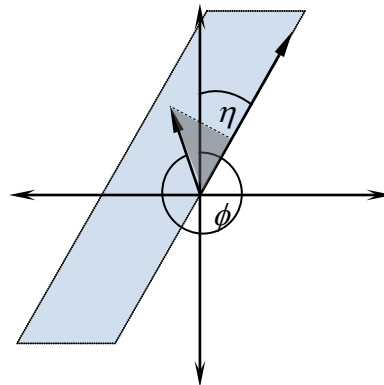

Figure 42: If $(\phi - \frac{3\pi}{2}) > \eta$ then
 $\delta_{ij} = 2\pi - \phi + \eta$ (14)

e) Solar Azimuth is in the first quadrant and Path Azimuth is in the second one:

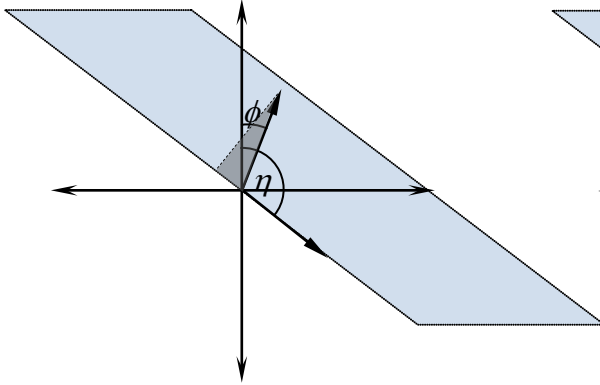

Figure 43: If $(\eta - \frac{\pi}{2}) < \phi$ then

$$\delta_{ij} = \pi - \eta + \phi \quad (15)$$

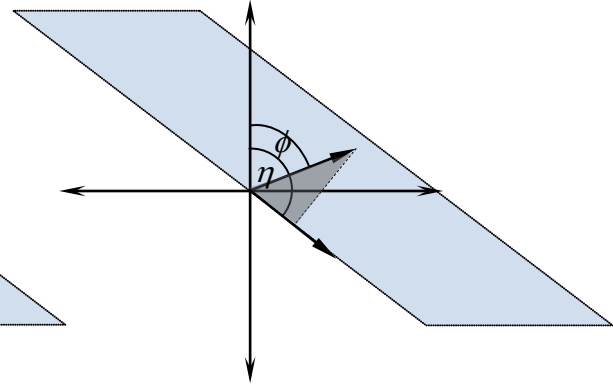

Figure 44: If $(\eta - \frac{\pi}{2}) > \phi$ then

$$\delta_{ij} = \eta - \phi \quad (16)$$

f) Solar Azimuth is in the first quadrant and Path Azimuth is in the third one:

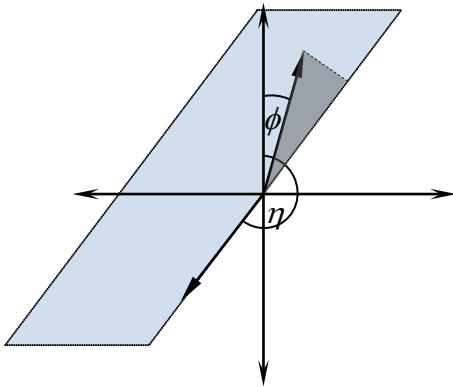

Figure 45: If $(\eta - \pi) > \phi$ then

$$\delta_{ij} = \eta - \phi \quad (17)$$

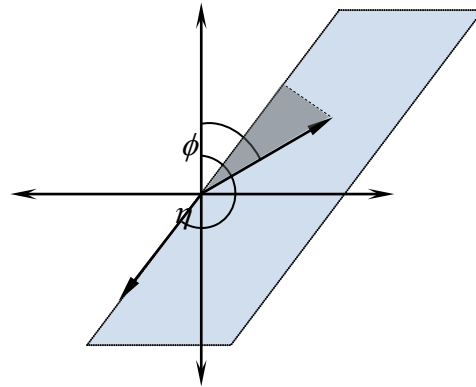

Figure 46: If $(\eta - \pi) < \phi$ then

$$\delta_{ij} = \phi - (\eta - \pi) \quad (18)$$

g) Both Solar Azimuth and Path Azimuth are in the second quadrant:

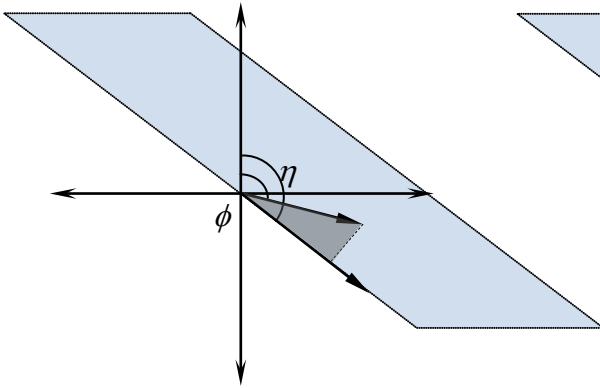

Figure 47: If $\eta > \phi$ then
 $\delta_{ij} = \eta - \phi$ (19)

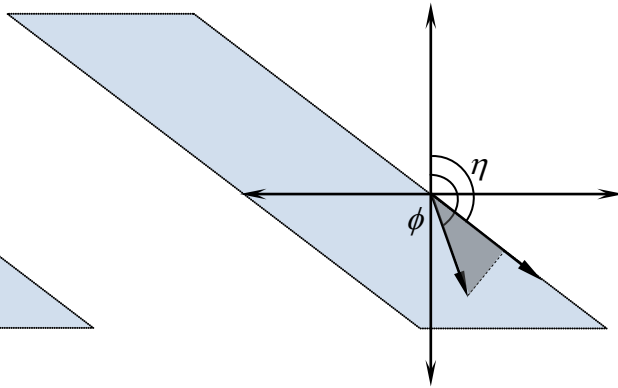

Figure 48: If $\eta < \phi$ then
 $\delta_{ij} = \phi - \eta$ (20)

h) Solar Azimuth is in second quadrant and Path Azimuth is in the third one:

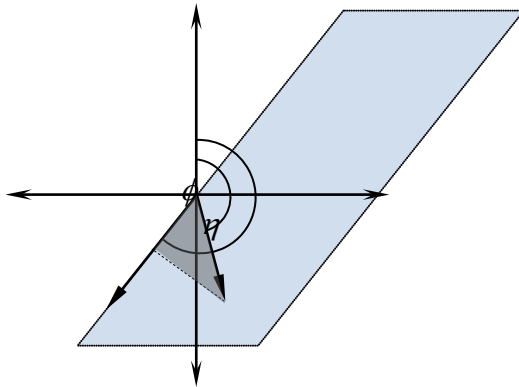

Figure 49: If $(\eta - \pi) > (\phi - \frac{\pi}{2})$ then
 $\delta_{ij} = \eta - \phi$ (21)

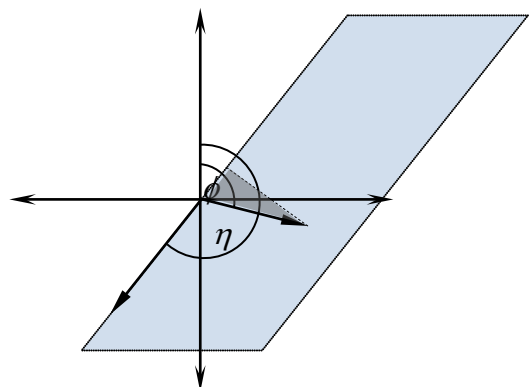

Figure 50: If $(\eta - \pi) < (\phi - \frac{\pi}{2})$ then
 $\delta_{ij} = \pi + \phi - \eta$ (22)

i) Both Solar and Path Azimuths are in the third quadrant:

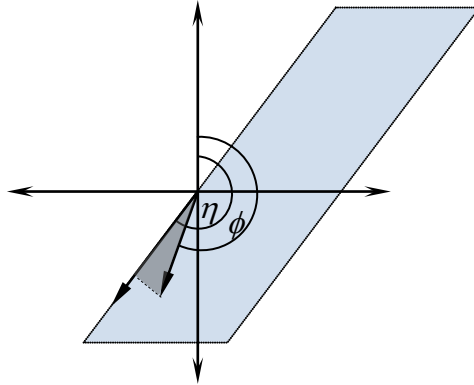

Figure 51: If η is greater than ϕ then

$$\delta_{ij} = \eta - \phi \quad (23)$$

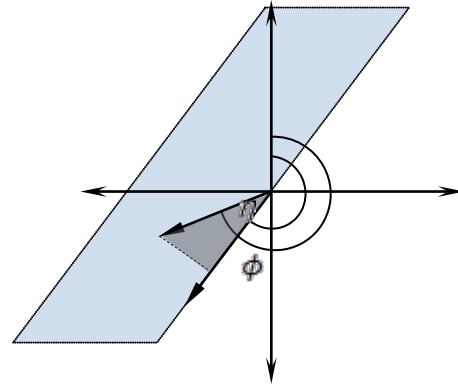

Figure 52: If η is less than ϕ then

$$\delta_{ij} = \phi - \eta \quad (24)$$

j) Path Azimuths is in the third quadrant and Solar Azimuth is in the fourth one:

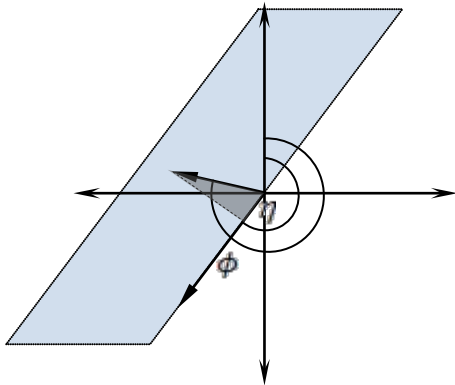

Figure 53: If $(\phi - \frac{3\pi}{2}) < (\eta - \pi)$ then

$$\delta_{ij} = \phi - \eta \quad (25)$$

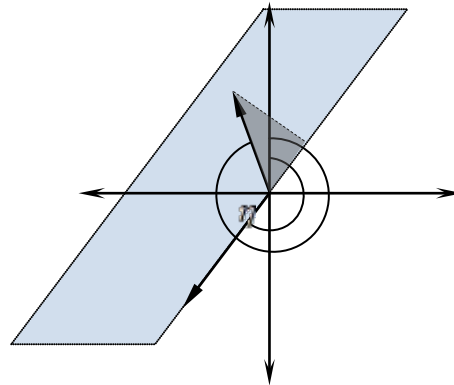

Figure 54: If $(\phi - \frac{3\pi}{2}) > (\eta - \pi)$ then

$$\delta_{ij} = \pi + \eta - \phi \quad (26)$$

k) Both Path and Solar Azimuths are in the fourth quadrant:

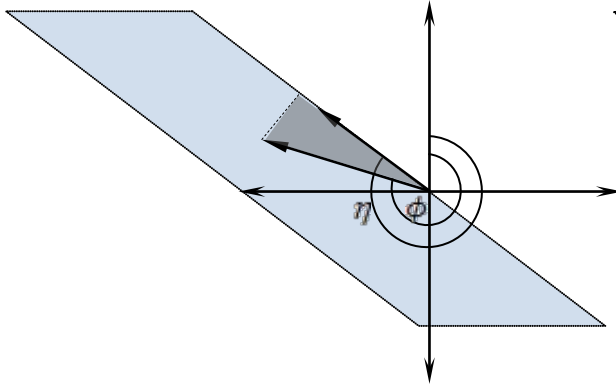

Figure 55: If $\eta > \phi$ then
 $\delta_{ij} = \eta - \phi$ (27)

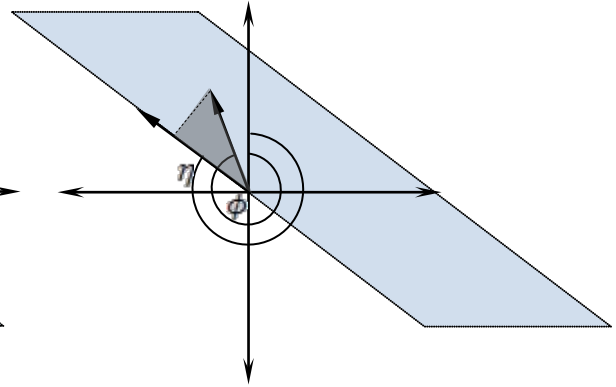

Figure 56: If $\eta < \phi$ then
 $\delta_{ij} = \phi - \eta$ (28)

Beyond the above considerations, some assumptions related to shadow making are required:

- a) The enemy searcher has an unlimited omnidirectional sensing, implying no random search model. As a result, this research intends to study and analyze the worst possible tactical and operational situation to combat logistics planners. The choice for that approach is due to the critical features of a search problem concerned with the nature of the target in space and time and the method and efficiency of the search;
- b) Point light sources do not exist in practice, and hard shadows give a rather unrealistic feeling to images. Even the sun, probably the most common shadow-creating light source in our daily life has a significant angular extent and does not create hard shadows. In the more realistic case of a light source with finite extent, a point on the receiver can have a partial view of the light, i.e. only a fraction of the light source is visible from that point;

- c) The path surroundings consist laterally of the light obstacles (i.e. riverine vegetation) that can occlude the move from the observer's sensors;
- d) The distance between the water surface and riverine forest ground is minor and insignificant in the final calculation outcome;
- e) Shades created by sunlight are *hard shadows*, that is to say they are produced by a point light source, rather than *soft ones*. Therefore, the shadows across the river are made only to shade, and appear entirely black. As a result, the move will travel completely or partially hidden, depending on what percentage of the boat is in the shadow.

Survivability Alternative Approaches

The risk between each network node can be easily computed using formula (6). However, the total travel risk doesn't necessarily mean the sum of the partial ones. Since risk was defined as a state of uncertainty for which the probability distribution is known, computing the total travel risk depends on how much each individual move affects the total mobility performance in terms of exposure level. Therefore, the approach in which these probabilistic outcomes are counted will define the travel risk through the total route.

In this research are suggested four different mathematical-based perspectives whose applicability is dependent on the camp commander's point of view, as well as his logistics staff, in terms of mission criticality.

The first alternative, called the fastest travel, computes the total travel risk taken into account the shortest path between depot and deployed combat unit, regardless of

individual risk paths. The goal is to assess the total exposure level considering the move needs to reach the destination as soon as possible.

A second and more conservative approach is finding a route with zero-exposure to enemy fire. This point of view is elementary since it is based on the sum of individual risks. However, it neglects the exposure time on each path, as well as different route combinations. It's a relative measure instead of an absolute one. Consequently, it is impossible to compare two or more options in which the number of paths transversed on each alternative route is different.

For example, if in a hypothetical movement, from point A to B, an option 1 has individual path risks of (0, 0.5, 0.5, 0, 0.5) and option 2 has risk of (0.5, 0.5, 0.5), the two options have the same total risk (1.5). However, the exposure to enemy fire is at different times, which, by inference, suggests that option 2 can be more dangerous than option 1. Also, these sums can result in values greater than 1, which annuls its probabilistic meaning. Mathematically it can be defined as the following:

$$\text{Total risk} = \lambda = \sum_{i=1}^n \lambda_{it} \quad (29)$$

Where:

- a) λ_{it} : risk on arc i at time t ;
- b) n : total number of arcs on path;

The third perspective is found on the rudimentary principles of serial reliability of components in military operations and systems (Przemieniecki, 2000:231-232; Zehna, 2005:305-309). In this approach, the reliability of a military operation is measured in terms of its probability of success. Thus, the probability of success of a series of

components comprising the overall mission is the probability of success of independent events. Since all components in that system operate in order for the whole operation to be successful. The problem with this method is related to difficulty in measuring the effect of each leg on the overall mission fulfillment. For example, if the movement is completely vulnerable, i.e. unhidden, in a unique course, the military operation reliability will be zero. However, this tool becomes important when it is necessary to identify the options in which there is a great possibility that the boat will be sunk. The route survivability is computed using the following formula:

$$Survivability = \mu = \prod_{i=1}^n (1 - \lambda_{it}) \quad (30)$$

Where:

- a) λ_{it} : risk on arc i at time t ;
- b) n : total number of arcs on path;

The fourth option is a time-dependent survivability measure, which emphasizes the importance of the period of time that the move is completely or partially disclosure. Under this perspective, it is possible to compare different scenarios, regardless of start times, total number of paths taken, and total travel time. The weighted-survivability is calculated employing the equation below.

$$weighted - survivability = \psi_{ijt} = \frac{\sum_{i=1}^n \mu_{it} \times \tau_{ij}}{T} \quad (31)$$

Where:

- a) μ_{it} : survivability on arc i at time t ;

- b) n : total number of arcs on path;
- c) τ_{ij} : travel time between nodes i and j ;
- d) T : total travel time.

It is important to highlighted that there is no an absolute “best” or “superior” option to calculate either total travel risk or total travel vulnerability since all models are found on probabilistic analysis (Leedy and Ormrod, 2009:259-260). The alternative methods, as descriptive statistics, are measures of the moves behavioral tendency. These methods are based on problem assumptions and are subject to interpretation. A prespecified focus or goal must to be defined in advance in order to choose the most appropriate tool for analyzing the problem.

Finally, beyond the above considerations, some assumptions related to risk as well as survivability evaluation are required:

- a) Risk between any two nodes is calculated based on the second node’s data, in terms of its geographical coordinates, and solar position data (sun azimuth and sun altitude);
- b) Since risk is dependent of the trinomial move/location/time, it is in constant change.

However, to simplify the calculations risk is considered constant on each path.

Graph Algorithms

A graph $G = (V, E)$ is defined by a set of vertices V , and a set of edges E consisting of ordered or unordered pairs of vertices from V . In a network, the vertices may represent the nodes or junctions. Certain pairs of which are connected by edges, which can be wires, roads, rivers, pipes, and so on (Papadimitriou and Steiglitz, 1998:20).

The basic operation in most graph algorithms is completely and systematically traversing the graph, visiting every vertex and every edge exactly once in some well-defined order. There are two primary kinds of traversal algorithms: Breadth-first Search (BFS) and Depth-first Search (DFS) (Castillo and others, 1996:160; Gross and Yellen, 1998:130). For certain problems, it makes absolutely no difference which one you use, but in other cases the distinction is crucial. Both graph traversal procedures share one fundamental idea, namely, that it is necessary to mark the vertices seen before so they aren't explored again. BFS and DFS differ only in the order in which they explore vertices.

The BFS algorithm starts at a given vertex, which is at level 0. In the first stage, all vertices are visited at level 1. In the second stage, all vertices of the second level are visited. These are new vertices, which are adjacent to level 1 vertices (Cormen and others, 2001:531). The BFS traversal terminates when every vertex has been visited. It's used to solve the following problems:

- a) Testing whether a graph is connected.
- b) Computing a spanning forest of graph.
- c) Computing, for every vertex in graph, a path with the minimum number of edges between start vertex and current vertex or reporting that no such path exists.
- d) Computing a cycle in graph or reporting that no such cycle exists.

The DFS algorithm starts at a specific vertex-source (S) in G , which becomes the current vertex. The algorithm traverses the graph by any edge (X_i, X_j) incident to the current vertex u . If the edge (X_i, X_j) leads to an already visited vertex X_j , then we backtrack to current vertex X_i . Backtracking ensures correctness by enumerating all

possibilities. It ensures efficiency by never visiting a state more than once. If, on the other hand, edge (X_i, X_j) leads to an unvisited vertex X_j , then we go to X_j and X_j becomes our current vertex. We proceed in this manner until we reach a “deadend”. At this point we start back tracking. The process terminates when backtracking leads back to the start vertex (Cormen and others, 2001:541-542). Edges that lead to new vertex are called discovery or tree edges and edges that lead to already visited edges are called “back edges”. DFS algorithm is used to solve the following problems.

- a) Testing whether a graph is connected.
- b) Computing a spanning forest of graph.
- c) Computing a path between two vertices of graph or equivalently reporting that no such path exists.
- d) Computing a cycle in graph or equivalently reporting that no such cycle exists.

There are two points to remember about using BFS to find a shortest path from X_i to X_j : First, the shortest path tree is only useful if BFS was performed with x as the root of the search. Second, BFS only gives the shortest path if the graph is unweighted. Therefore, either simple DFS or BFS is able to solve the purposed problem. However, the Dijkstra's single source shortest path algorithm, a well-known algorithmic program used in routing problems, which uses the BFS principle, is a good option to compute the total travel risk.

Dijkstra's Algorithm

The Dijkstra's Algorithm is one of the most celebrated algorithms in the Computer Science and very popular in the Operations Research (Avron and others,

2008:589; Du and others, 2009:187). One of the main reasons for its popularity is its use in generating (exact) optimal solutions to a large class of shortest path problems (Bubak and others, 2004:965; LaValle, 2006:47). Also, the main point is that the shortest path problem is extremely important theoretically as well as practically, because any combinatorial optimization problem is formulated as a shortest path problem (Papadimitriou and Steiglitz 1998:75). This class of problems is extremely large and includes numerous practical problems that have nothing to do with actual (“genuine”) shortest path problems.

The typical descriptions of this algorithm start by postulating that the shortest paths be enumerated in the order of increasing distances from the source (Sack and Urrutia, 2001:636). Basically, it works by solving a subproblem k , which computes the shortest path from the source v to vertices among the k closest vertices to the source (Zang, 2002:17). However for the Dijkstra’s algorithm works it should be directed-weighted graph and the edges should be non-negative (Cormen and others, 2001:582; Manber, 1989:204-206). If the edges are negative then the actual shortest path cannot be obtained. At the k th round, there will be a set called frontier of k vertices that will consist of the vertices closest to the source and the vertices that lie outside frontier are computed and put into new frontier. The shortest distance obtained is stored in $w.SP$. It holds the estimate of the distance from v to w . Dijkstra’s algorithm finds the next closest vertex by maintaining the new frontier vertices in a priority-min queue (Cormen and others, 2001:599).

The algorithm works by keeping the shortest distance of vertex w from the source v in an array, $w.SP$. The shortest distance of the source to itself is zero. The $w.SP$ for all

other vertices is set to infinity to indicate that those vertices are not yet processed. After the algorithm finishes the processing of the vertices, $w.SP$ will have the shortest distance of vertex v to w . Two sets are maintained, frontier and new frontier, which helps in the processing of the algorithm. Frontier has k vertices which are closest to the source, will have already computed shortest distances to these vertices, for paths restricted up to k vertices. The vertices that reside outside of frontier are put in a set called new frontier. The following lines present the Dijkstra's algorithm's pseudocode (Manber, 1989:206)

Input: $G = (V, E)$ (a weighted directed graph), and v (the source vertex)
Output: for each vertex w , $w.SP$ is the length of the shortest path from v to w .
 {all lengths are assumed to be nonnegative}.

begin

for all vertices w *do*

$w.mark := false$;

$v.SP := \infty$;

$v.SP := 0$;

while there exist an unmarked vertex *do*

 let w be an unmarked vertex such $w.SP$ is minimal ;

$w.mark := true$;

for all edges (w,v) such that z is unmarked *do*

if $w.SP + length(w, z) < z.SP$ *then*

$z.SP := w.SP + length(w, z)$

end

In this research, as previously mentioned, the path weights are based on travel risk instead of travel cost. Dijkstra's algorithm is still appropriate since the graph is direct-weighted and edges are always non-negative.

IV. Results and Analysis

Introduction

In order to determine the absolute performance of the designed model configuration under the assumptions previously set up both verification and validation processes were performed taking into account actual non-classified information from the Amazonian region in which the scenario problem was projected (Asner and others, 2002; McClain and others, 2001; Spencer, D., 2004).

Since these procedures are concerned with accuracy transformation and representation, are essential prerequisites to the credible and reliable use of this model as well as its results in military planning processes (Abu-Taieh and others, 2009:58; Banks and Carson, 1996; Kheir, 1996:220; Law, 2007:243-244). Therefore, based on current simulation literature, some methods were selected to verify and validate the present model.

For verification, the data analysis process was employed. The model validation, on the other hand, was obtained using cause-effect graphing method, extreme conditions test, and predictive validation dynamic methods (Abu-Taieh and others, 2009:60-65).

Problem Model Representation

One of the most difficult problems facing a simulation analysis is trying to determine whether a model is an accurate representation of the system being studied (Kent and Williams, 1990:232; Law, 2007:243; Lenhard and others, 2006:150). Based on this assertion, real data about tropical and subtropical moist broadleaf forest environment, particularly from the Brazilian Amazon basin, was collected before starting any kind of

model assessment (figure 57). This data was translated into a theoretical network, which constitutes graphic representation of a hypothetical theater of operations in which military supply missions will be performed (figures 58 and 59).

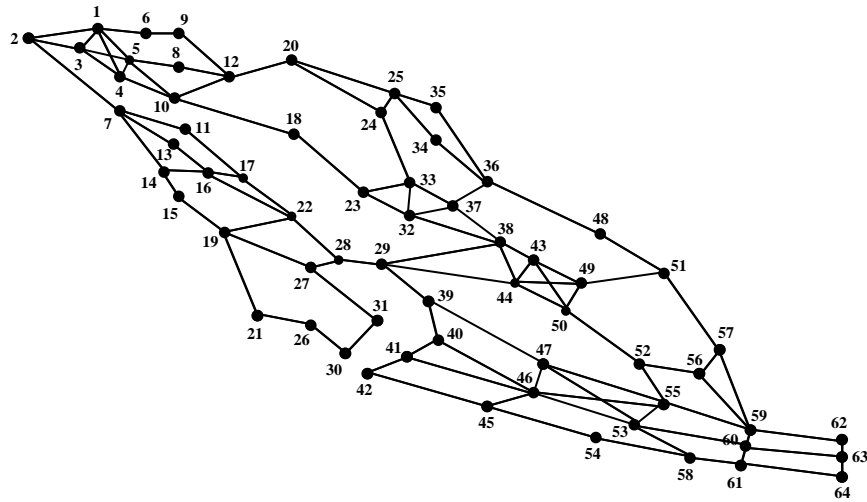

Figure 57. Theoretical network plot.

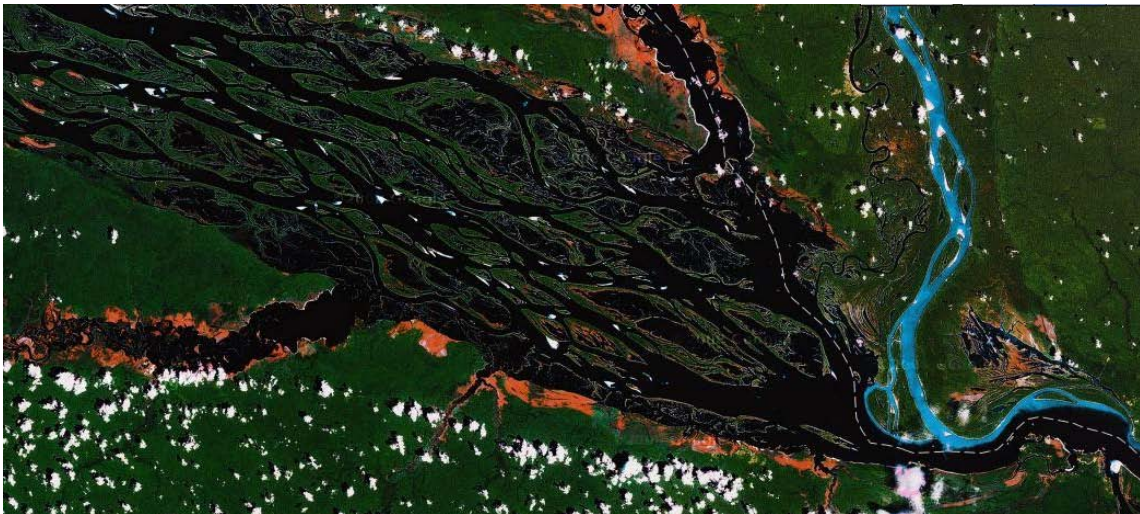

Figure 58. Amazon region satellite picture.



Figure 59. Theoretical network based on real watercourse system.

The theoretical network is composed of 64 distinct nodes with arcs connections the nodes as shown in the figure 57. The nodes are identified by its geographical coordinates (Appendix A). These points represent all possible locations for both a small deployed combat force and a military depot station responsible for supporting the combat force.

Verification Process

The verification process refers to a testing procedure that determines whether a system is consistent with its designations as well as both problem assumptions and circumstantial issues related to the question have been correctly translated into a computer program (Law, 2007:243). The typical questions to be answered during this process include (Sokolowski and Banks, 2009:126):

- a) Does the program code of the executable model correctly implement the conceptual model?
- b) Does the conceptual model satisfy the intended uses of the model?

- c) Does the executable model produce results when it's needed and in the required format?

To answer these questions the following experiment was performed:

- a) The logical-mathematical consistency between the conceptual model and coding system were evaluated comparing the set of functions and variables with its counterparts as well as the theoretical constructs that represents the phenomena in study, like physical laws, hypothesis and related theories.

Data Analysis

This verification tool compares data definitions and operations in the conceptual model to those in the executable one. It includes data dependency analysis, which determines which variable depends on the other one, and data flow analysis. This is useful for undefined and unused data and is also helpful in identifying inconsistencies in data structure and improper linkages among data items (Ledin, 2001:209-210).

Though all computation are performed in the VBA environment, it's possible to attest model congruence in terms of parameter dependences, by bringing functions and variables employed in the coding process from VBA to an Excel Spreadsheet and examining their connections. For example, as mentioned on chapter III, risk level depends directly on the pair sun-move position, since their relative location generates (or not) shadow areas. That internal relationship can be identified comparing the content of the red rectangles (figures 60 and 61), with the real-world source (figures 62 and 63), as well as the changes due to alteration in one argument, particularly in the timeframe (from 8:00am to 7:00am).

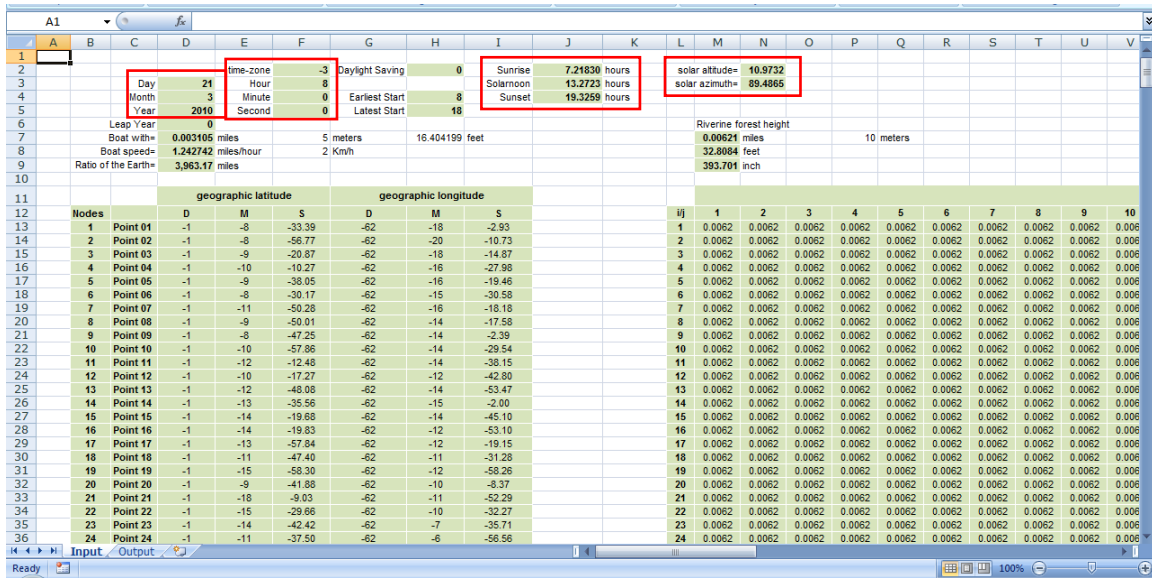

Figure 60. Excel Spreadsheet screenshot showing the relationship among the solar position parameters and timeframe (on March 21th 2010, at 8:00am).

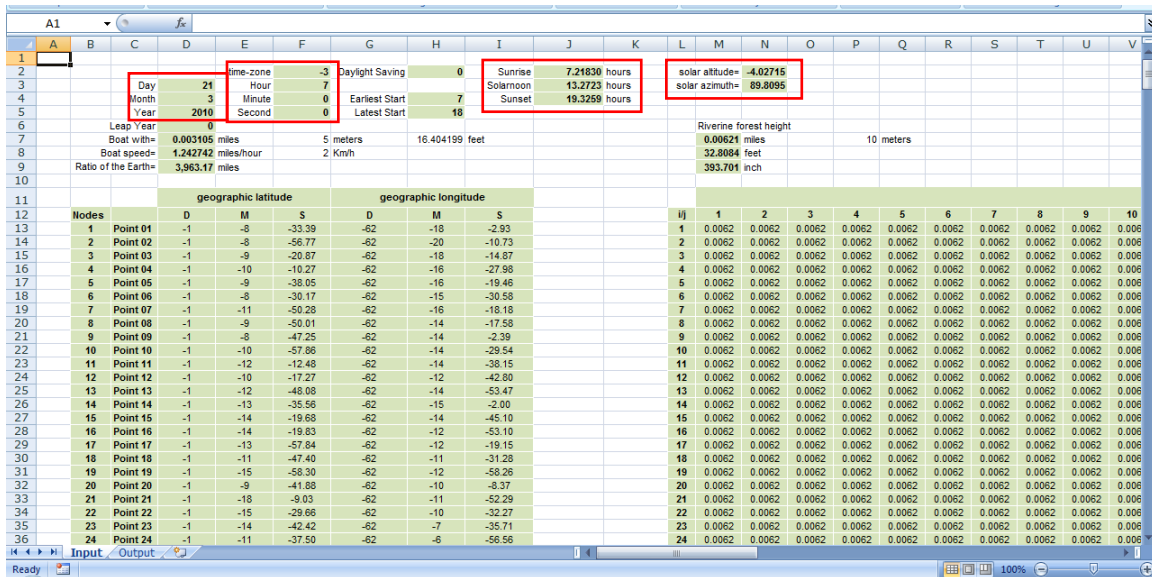

Figure 61. Excel Spreadsheet screenshot showing the relationship among the solar position parameters and timeframe (on March 21th 2010, at 7:00am).

It is possible to note on the above pictures that before the sunrise time (over 7.2183 hours, i.e. 7h 13min) solar altitude has a negative value, which can be confirmed on the NOAA Solar Calculator website (figures 62 and 63).

U.S. Department of Commerce | National Oceanic & Atmospheric Administration | NOAA Research

Earth System Research Laboratory
Global Monitoring Division

Search ESRL:
Calendar | People | Publications

Global Monitoring Division About Research Products Outreach Information Intranet

G-Rad Home
Personnel
Publications

Observing Networks
Globally Remote Sites
SURFRAD Network
NEUBrew Network

Measurements & Instruments

Data Downloads
MLO Transmission
Daily G-Rad Plots
G-Rad FTP Server
SRRB FTP Server

Calibration Facilities
Broadband Solar
Central UV Calibration Facility

Solar Calculators
Sunrise/Sunset
Solar Position

GMD Organization
Contact GMD
GMD Intranet
G-Rad Internal Pages

NOAA Solar Calculator

Find Sunrise, Sunset, Solar Noon and Solar Position for Any Place on Earth

Show: World Cities U.S. Cities GMD Observ.'s GMD Data Sites SurfRad

Click one of the small pins near (and in the same time zone as) your desired location. Use the control on the left side of the map to zoom in or out. Place the large pin in the exact desired location.
You can use the Save button to have your computer remember the current location for next time. Check the DST check box if Daylight Saving Time is in effect for your site.

Map Satellite Hybrid

Location: Lat -1.143 Lng -62.301 Time Zone -3 DST? Save

Date: Day 21 Mon Mar Yr 2010 Local 08 : 00 : 00 Time: PM

| Equation of Time (minutes): | Solar Declination (degrees): | Apparent Sunrise: | Solar Noon: | Apparent Sunset: | Current Az/EI (degrees): |
|-----------------------------|------------------------------|-------------------|-------------|------------------|--------------------------|
| -7.2 | 0.29 | 07:13 | 13:16:20 | 19:20 | 89.49 10.97 |

Show on map: Sunrise Sunset Current

Figure 62. NOAA Solar Calculation screenshot showing the relationship among the solar position parameters and timeframe (on March 21th 2010, at 8:00am).

Broadband Solar
Central UV Calibration Facility

Solar Calculators
Sunrise/Sunset
Solar Position

GMD Organization
Contact GMD
GMD Intranet
G-Rad Internal Pages

Location: Lat -1.142608 Lng -62.300813 Time Zone -3 DST? Save

Date: Day 21 Mon Mar Yr 2010 Local 07 : 00 : 00 Time: PM

| Equation of Time (minutes): | Solar Declination (degrees): | Apparent Sunrise: | Solar Noon: | Apparent Sunset: | Current Az/EI (degrees): |
|-----------------------------|------------------------------|-------------------|-------------|------------------|--------------------------|
| -7.21 | 0.27 | 07:13 | 13:16:20 | 19:20 | 89.81 -4.03 |

Show on map: Sunrise Sunset Current

Figure 63. NOAA Solar Calculation screenshot showing the relationship among the solar position parameters and timeframe (on March 21th 2010, at 7:00am).

Since path azimuth is essential data to risk computation, its estimation is evaluated in the VBA environment (figure 64) compared against the values provided by distance and azimuth computation, found on the Federal Communication Commission (FCC) website (figure 65). In this condition, the path azimuth will be $360^{\circ} - 280.368^{\circ}$, which equals 79.63° .

```

'Calculate Path Azimuth in Degrees'
Dim AZij_d As Double
AZij_d = 180 / pi
AZij_d = 280.369551103111
'GET INFORMATION about hight riverine forest'
tree = Worksheets("Input").Cells(12 + i, 12 + j).Value 'Get Riverine Forest Height'

'Calculate Average Latitude between Points i and j'
avg_lat = (Rad_lat_i + Rad_lat_j) / 2

'Calculate Solar Azimuth'
SolAz_d = solarazimuth(DD_lat_j, DD_lon_j, year, month, day, hour, min, sec, TZ, D)
SolAz = SolAz_d * pi / 180

'Calculate Solar Altitude'
Dim Sol_alt_d As Double
Sol_alt_d = solarelevation(DD_lat_j, DD_lon_j, year, month, day, hour, min, sec, TZ, D)
Sol_alt = Sol_alt_d * pi / 180

'Calculate the Difference between Solar Azimuth and Path Azimuth'
'Both Solar Azimuth and Path Azimuth are in the first quadrant'
If AZij <= pi / 2 And SolAz <= pi / 2 Then
  If SolAz > AZij Then
    diff_AZij_solAZ = SolAz - AZij
  Else: diff_AZij_solAZ = AZij - SolAz

```

Figure 64. Excel VBA screenshot showing the path azimuth calculation, between nodes 1 and 2, computed by program computer.

FCC Home | Search | Updates | E-Filing | Initiatives | For Consumers | Find People

Audio Division | Distance, Bearing Between Two Sets of Coordinates

(202)-418-2700 | FCC > MB > Audio Division > Distance Computations and Find Terminal Coordinates | FCC site map

Find Distance and Azimuths Between 2 Sets of Coordinates -- Results

Distance between

S Latitude 1 8 33.39, W Longitude 62 18 2.93 (Point 1)
and S Latitude 1 8 56.77, W Longitude 62 20 10.73 (Point 2)

4.012 kilometers; 2.493 miles

Azimuth from point 1 to point 2 = 259.63°
Azimuth from point 2 to point 1 = 79.63°

[Another Distance Computation?](#)

Use [Sprong](#) to find the terminal or end coordinates, given a bearing and a distance.

This program is located at <http://www.fcc.gov/fcc-bin/audio/distance.html>

FCC Home | Search | RSS | Updates | E-Filing | Initiatives | Consumers | Find People

If you would like more information pertaining to the Media Bureau, please call: (202) 418-7200.

Figure 65. FCC Distance and Azimuth Calculation showing the path azimuth between nodes 1 and 2.

Using data analysis techniques it was possible to verify the computer program against conceptual model comparing functions and variables that represents the phenomena in study. This assesses as a result, its logical-mathematical consistency.

Validation Process

According to current simulation literature, validation process refers to a testing procedure that determines whether a system satisfies the user requirements by comparing simulation results derived from the model against the real-world system. Also, it's understood as a "process of determining the degree to which the model is an accurate representation of the real world" (DoD, 1996). "Degree" is a subjective term, so a model is considered valid when it's a reasonable representation of the real system.

In general, the validation of models of physical phenomena is straightforward since the laws of nature are usually well known and mathematically precise. In this specific case, the model is validated by comparing the results of running the model with observations from the real world (Zacharias and others, 2008:343). However, in order to standardize its process, some typical and standard questions need to be answered, which include (Sokolowski and Banks, 2009:126):

- a) Is the conceptual model a correct representation of the simulation?
- b) How close are the results produced by the executable model to the behavior of the real world?
- c) Under what range of inputs are the model's results credible and useful?

To achieve these objectives the following tests were performed:

- a) The model was evaluated on the extremes scenarios, that is, under the non-existence of riverine forest as well as in the presence of extremely high trees surrounding the routes;
- b) The boat speed was progressively changed from a small value to a large one;
- c) The boat width was progressively changed from a small value to a large one.

Extreme Condition Tests

This first procedure consists in selecting utmost numerical inputs, in which the model outcome is easily predicable, considering its senselessness and improbable combination of levels in parts of the model. This is used to check whether the model responds accordantly, in other words, presenting also extremes results (Abu-Taieh and others, 2009:63). The two more significant instances in this study are related to the total absence of vegetation along the river, which doesn't produce shadow at all, and incredibly high trees, the "perfect shadow makers".

The figures 66, 67 and 68 present the input and outcome screenshots, showing what information was placed as well as the respective results. In these pictures, it is evident the complete lack of trees doesn't produce shadow areas and, as result, the relative risk level decreases over time, depending on the move start time. At the same time, the probability of mission success, i.e. survivability, is zero. The four subsequent figures (69 to 72), graphically display the model behavior, exactly as it was expected.

| Nodes | D | M | S | D | M | S | Hj | 1 | 2 | 3 | 4 | 5 | 6 | 7 | 8 | 9 | 10 | 11 |
|-------------|----|-----|--------|-----|-----|--------|----|--------|--------|--------|--------|--------|--------|--------|--------|--------|--------|--------|
| 1 Point 01 | -1 | -8 | -33.39 | -62 | -18 | -2.93 | 1 | 0.0000 | 0.0000 | 0.0000 | 0.0000 | 0.0000 | 0.0000 | 0.0000 | 0.0000 | 0.0000 | 0.0000 | 0.0000 |
| 2 Point 02 | -1 | -8 | -56.77 | -62 | -20 | -10.73 | 2 | 0.0000 | 0.0000 | 0.0000 | 0.0000 | 0.0000 | 0.0000 | 0.0000 | 0.0000 | 0.0000 | 0.0000 | 0.0000 |
| 3 Point 03 | -1 | -9 | -20.87 | -62 | -18 | -14.87 | 3 | 0.0000 | 0.0000 | 0.0000 | 0.0000 | 0.0000 | 0.0000 | 0.0000 | 0.0000 | 0.0000 | 0.0000 | 0.0000 |
| 4 Point 04 | -1 | -10 | -10.27 | -62 | -16 | -27.98 | 4 | 0.0000 | 0.0000 | 0.0000 | 0.0000 | 0.0000 | 0.0000 | 0.0000 | 0.0000 | 0.0000 | 0.0000 | 0.0000 |
| 5 Point 05 | -1 | -9 | -38.05 | -62 | -16 | -19.48 | 5 | 0.0000 | 0.0000 | 0.0000 | 0.0000 | 0.0000 | 0.0000 | 0.0000 | 0.0000 | 0.0000 | 0.0000 | 0.0000 |
| 6 Point 06 | -1 | -9 | -30.17 | -62 | -15 | -30.58 | 6 | 0.0000 | 0.0000 | 0.0000 | 0.0000 | 0.0000 | 0.0000 | 0.0000 | 0.0000 | 0.0000 | 0.0000 | 0.0000 |
| 7 Point 07 | -1 | -11 | -50.23 | -62 | -16 | -18.18 | 7 | 0.0000 | 0.0000 | 0.0000 | 0.0000 | 0.0000 | 0.0000 | 0.0000 | 0.0000 | 0.0000 | 0.0000 | 0.0000 |
| 8 Point 08 | -1 | -9 | -50.01 | -62 | -14 | -17.58 | 8 | 0.0000 | 0.0000 | 0.0000 | 0.0000 | 0.0000 | 0.0000 | 0.0000 | 0.0000 | 0.0000 | 0.0000 | 0.0000 |
| 9 Point 09 | -1 | -8 | -47.25 | -62 | -14 | -2.39 | 9 | 0.0000 | 0.0000 | 0.0000 | 0.0000 | 0.0000 | 0.0000 | 0.0000 | 0.0000 | 0.0000 | 0.0000 | 0.0000 |
| 10 Point 10 | -1 | -10 | -57.86 | -62 | -14 | -29.54 | 10 | 0.0000 | 0.0000 | 0.0000 | 0.0000 | 0.0000 | 0.0000 | 0.0000 | 0.0000 | 0.0000 | 0.0000 | 0.0000 |
| 11 Point 11 | -1 | -12 | -12.48 | -62 | -14 | -38.15 | 11 | 0.0000 | 0.0000 | 0.0000 | 0.0000 | 0.0000 | 0.0000 | 0.0000 | 0.0000 | 0.0000 | 0.0000 | 0.0000 |
| 12 Point 12 | -1 | -10 | -17.27 | -62 | -12 | -42.80 | 12 | 0.0000 | 0.0000 | 0.0000 | 0.0000 | 0.0000 | 0.0000 | 0.0000 | 0.0000 | 0.0000 | 0.0000 | 0.0000 |
| 13 Point 13 | -1 | -12 | -46.08 | -62 | -14 | -53.47 | 13 | 0.0000 | 0.0000 | 0.0000 | 0.0000 | 0.0000 | 0.0000 | 0.0000 | 0.0000 | 0.0000 | 0.0000 | 0.0000 |
| 14 Point 14 | -1 | -13 | -35.56 | -62 | -15 | -2.00 | 14 | 0.0000 | 0.0000 | 0.0000 | 0.0000 | 0.0000 | 0.0000 | 0.0000 | 0.0000 | 0.0000 | 0.0000 | 0.0000 |
| 15 Point 15 | -1 | -14 | -19.68 | -62 | -14 | -45.10 | 15 | 0.0000 | 0.0000 | 0.0000 | 0.0000 | 0.0000 | 0.0000 | 0.0000 | 0.0000 | 0.0000 | 0.0000 | 0.0000 |
| 16 Point 16 | -1 | -14 | -19.83 | -62 | -12 | -53.10 | 16 | 0.0000 | 0.0000 | 0.0000 | 0.0000 | 0.0000 | 0.0000 | 0.0000 | 0.0000 | 0.0000 | 0.0000 | 0.0000 |
| 17 Point 17 | -1 | -13 | -57.84 | -62 | -12 | -19.15 | 17 | 0.0000 | 0.0000 | 0.0000 | 0.0000 | 0.0000 | 0.0000 | 0.0000 | 0.0000 | 0.0000 | 0.0000 | 0.0000 |
| 18 Point 18 | -1 | -11 | -47.40 | -62 | -11 | -31.28 | 18 | 0.0000 | 0.0000 | 0.0000 | 0.0000 | 0.0000 | 0.0000 | 0.0000 | 0.0000 | 0.0000 | 0.0000 | 0.0000 |
| 19 Point 19 | -1 | -15 | -58.30 | -62 | -12 | -58.26 | 19 | 0.0000 | 0.0000 | 0.0000 | 0.0000 | 0.0000 | 0.0000 | 0.0000 | 0.0000 | 0.0000 | 0.0000 | 0.0000 |
| 20 Point 20 | -1 | -9 | -41.88 | -62 | -10 | -6.37 | 20 | 0.0000 | 0.0000 | 0.0000 | 0.0000 | 0.0000 | 0.0000 | 0.0000 | 0.0000 | 0.0000 | 0.0000 | 0.0000 |
| 21 Point 21 | -1 | -18 | -9.03 | -62 | -11 | -52.29 | 21 | 0.0000 | 0.0000 | 0.0000 | 0.0000 | 0.0000 | 0.0000 | 0.0000 | 0.0000 | 0.0000 | 0.0000 | 0.0000 |
| 22 Point 22 | -1 | -15 | -29.66 | -62 | -10 | -32.27 | 22 | 0.0000 | 0.0000 | 0.0000 | 0.0000 | 0.0000 | 0.0000 | 0.0000 | 0.0000 | 0.0000 | 0.0000 | 0.0000 |
| 23 Point 23 | -1 | -14 | -42.42 | -62 | -7 | -35.71 | 23 | 0.0000 | 0.0000 | 0.0000 | 0.0000 | 0.0000 | 0.0000 | 0.0000 | 0.0000 | 0.0000 | 0.0000 | 0.0000 |
| 24 Point 24 | -1 | -11 | -37.50 | -62 | -6 | -56.56 | 24 | 0.0000 | 0.0000 | 0.0000 | 0.0000 | 0.0000 | 0.0000 | 0.0000 | 0.0000 | 0.0000 | 0.0000 | 0.0000 |

Figure 66. Input Spreadsheet's Excel screenshot, considering 30-minute interval departure.

| Fastest Path | Risk | Time | Survivability | Weighted Survivability |
|--------------|-----------|--------|---------------|------------------------|
| 1 | | | | |
| 2 | 38 | 1.0000 | 1.8017 | 0.0000 |
| 3 | 32 | 1.0000 | 1.1358 | 0.0000 |
| 4 | 23 | 1.0000 | 3.0245 | 0.0000 |
| 5 | 18 | 1.0000 | 1.9066 | 0.0000 |
| 6 | 10 | 1.0000 | 1.3999 | 0.0000 |
| 7 | 5 | 1.0000 | 1.2574 | 0.0000 |
| 8 | 1 | 0.0000 | 0.0000 | 0.0000 |
| 9 | | | | |
| 10 | | 6.0000 | 10.5259 | 0.0000 |
| 11 | | | | |
| 12 | Path 8:00 | Risk | Time | Survivability |
| 13 | 38 | 0.0000 | 2.3661 | 1.0000 |
| 14 | 29 | 0.0000 | 1.5024 | 1.0000 |
| 15 | 28 | 0.0000 | 2.5262 | 1.0000 |
| 16 | 27 | 0.0000 | 5.0358 | 1.0000 |
| 17 | 19 | 1.0000 | 1.4985 | 0.0000 |
| 18 | 15 | 1.0000 | 0.4870 | 0.0000 |
| 19 | 14 | 1.0000 | 1.3393 | 0.0000 |
| 20 | 7 | 1.0000 | 2.9902 | 0.0000 |
| 21 | 2 | 1.0000 | 1.3389 | 0.0000 |
| 22 | 1 | 0.0000 | 0.0000 | 1.0000 |
| 23 | | | | |
| 24 | | 5.0000 | 19.0844 | 0.0000 |
| 25 | | | | |
| 26 | Path 8:30 | Risk | Time | Survivability |
| 27 | 38 | 0.0000 | 2.3661 | 1.0000 |
| 28 | 29 | 0.0000 | 1.5024 | 1.0000 |
| 29 | 28 | 0.0000 | 2.5262 | 1.0000 |
| 30 | 27 | 0.0000 | 5.0358 | 1.0000 |
| 31 | 19 | 1.0000 | 1.4985 | 0.0000 |
| 32 | 15 | 1.0000 | 0.4870 | 0.0000 |
| 33 | 14 | 1.0000 | 1.3393 | 0.0000 |
| 34 | | | | |

Figure 67. Output Spreadsheet's Excel screenshot, considering 30-minute interval departure.

| Fastest Path | | | | | | | | | | |
|--------------|-----------|--------|---------------|------------------------|------------|-------|--------|---------------|------------------------|--------|
| Fastest Path | Risk | Time | Survivability | Weighted Survivability | Start Time | Risk | Time | Survivability | Weighted Survivability | |
| 1 | | | | | | | | | | |
| 2 | 35 | 1.0000 | 1.8017 | 0.0000 | 0.0000 | 8:00 | 5.0000 | 19.0844 | 0.0000 | 0.5989 |
| 3 | 32 | 1.0000 | 1.1358 | 0.0000 | 0.0000 | 8:15 | 5.0000 | 19.0844 | 0.0000 | 0.5989 |
| 4 | 23 | 1.0000 | 3.0245 | 0.0000 | 0.0000 | 8:30 | 5.0000 | 19.0844 | 0.0000 | 0.5989 |
| 5 | 18 | 1.0000 | 1.9066 | 0.0000 | 0.0000 | 8:45 | 5.0000 | 19.0844 | 0.0000 | 0.5989 |
| 6 | 10 | 1.0000 | 1.3999 | 0.0000 | 0.0000 | 9:00 | 5.0000 | 10.5259 | 0.0000 | 0.1712 |
| 7 | 5 | 1.0000 | 1.2574 | 0.0000 | 0.0000 | 9:15 | 5.0000 | 10.5259 | 0.0000 | 0.1712 |
| 8 | 1 | 0.0000 | 0.0000 | 1.0000 | 0.0000 | 9:30 | 5.0000 | 10.5259 | 0.0000 | 0.1712 |
| 9 | | | | | | 9:45 | 5.0000 | 13.6764 | 0.0000 | 0.3737 |
| 10 | | 6.0000 | 10.5259 | 0.0000 | 0.0000 | 10:00 | 5.0000 | 13.6764 | 0.0000 | 0.3737 |
| 11 | | | | | | 10:15 | 4.0000 | 10.5774 | 0.0000 | 0.2826 |
| 12 | Path 8:00 | | | | | 10:30 | 4.0000 | 10.5774 | 0.0000 | 0.2826 |
| 13 | 38 | 0.0000 | 2.3661 | 1.0000 | 2.3661 | 10:45 | 4.0000 | 10.5259 | 0.0000 | 0.2791 |
| 14 | 29 | 0.0000 | 1.5024 | 1.0000 | 1.5024 | 11:00 | 4.0000 | 10.5774 | 0.0000 | 0.2826 |
| 15 | 28 | 0.0000 | 2.5262 | 1.0000 | 2.5262 | 11:15 | 4.0000 | 10.5774 | 0.0000 | 0.2826 |
| 16 | 27 | 0.0000 | 5.0358 | 1.0000 | 5.0358 | 11:30 | 4.0000 | 10.5774 | 0.0000 | 0.2826 |
| 17 | 19 | 1.0000 | 1.4985 | 0.0000 | 0.0000 | 11:45 | 3.0000 | 10.5259 | 0.0000 | 0.5664 |
| 18 | 15 | 1.0000 | 0.4870 | 0.0000 | 0.0000 | 12:00 | 3.0000 | 10.5259 | 0.0000 | 0.5664 |
| 19 | 14 | 1.0000 | 1.3393 | 0.0000 | 0.0000 | 12:15 | 3.0000 | 13.7455 | 0.0000 | 0.6082 |
| 20 | 7 | 1.0000 | 2.9902 | 0.0000 | 0.0000 | 12:30 | 3.0000 | 13.7455 | 0.0000 | 0.6082 |
| 21 | 2 | 1.0000 | 1.3389 | 0.0000 | 0.0000 | 12:45 | 3.0000 | 13.7455 | 0.0000 | 0.6082 |
| 22 | 1 | 0.0000 | 0.0000 | 1.0000 | 0.0000 | 13:00 | 3.0000 | 13.7455 | 0.0000 | 0.6082 |
| 23 | | | | | | 13:15 | 3.0000 | 13.7455 | 0.0000 | 0.6082 |
| 24 | | 5.0000 | 19.0844 | 0.0000 | 0.5989 | 13:30 | 3.0000 | 13.7455 | 0.0000 | 0.6082 |
| 25 | | | | | | 13:45 | 2.0000 | 14.2977 | 0.0000 | 0.6972 |
| 26 | Path 8:15 | | | | | 14:00 | 2.0000 | 13.6764 | 0.0000 | 0.6835 |
| 27 | 38 | 0.0000 | 2.3661 | 1.0000 | 2.3661 | 14:15 | 2.0000 | 13.6764 | 0.0000 | 0.6835 |
| 28 | 29 | 0.0000 | 1.5024 | 1.0000 | 1.5024 | 14:30 | 2.0000 | 13.6764 | 0.0000 | 0.6835 |
| 29 | 28 | 0.0000 | 2.5262 | 1.0000 | 2.5262 | 14:45 | 2.0000 | 13.6764 | 0.0000 | 0.6835 |
| 30 | 27 | 0.0000 | 5.0358 | 1.0000 | 5.0358 | 15:00 | 1.0000 | 13.6764 | 0.0000 | 0.9021 |
| 31 | 19 | 1.0000 | 1.4985 | 0.0000 | 0.0000 | 15:15 | 1.0000 | 13.6764 | 0.0000 | 0.9021 |
| 32 | 15 | 1.0000 | 0.4870 | 0.0000 | 0.0000 | 15:30 | 1.0000 | 13.6764 | 0.0000 | 0.9021 |
| 33 | 14 | 1.0000 | 1.3393 | 0.0000 | 0.0000 | 15:45 | 1.0000 | 13.6764 | 0.0000 | 0.9021 |

Figure 68. Output Spreadsheet's Excel screenshot, considering 15-minute interval departure.

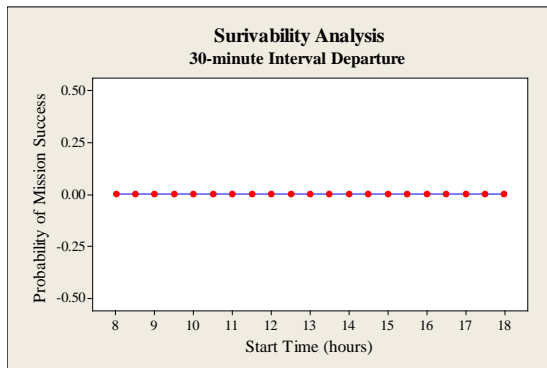

Figure 69. Graphic presenting the boat capability of surviving the supply mission under the absence of tree throughout the complete route, with 30-minute interval departure. Regardless start time, if one path has risk 1, the probability of mission success will be zero.

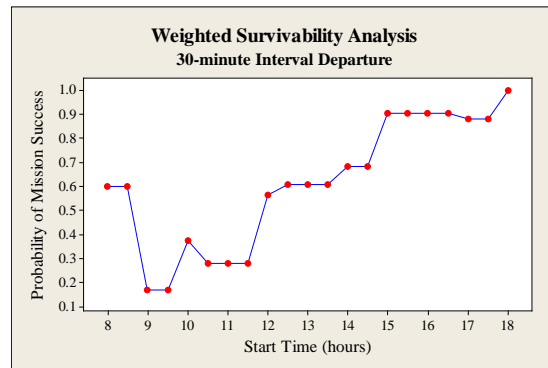

Figure 70. Graphic presenting the boat capability of surviving the supply mission under tree absence throughout the complete route, emphasizing the importance of travel time, with 30-minute interval departure.

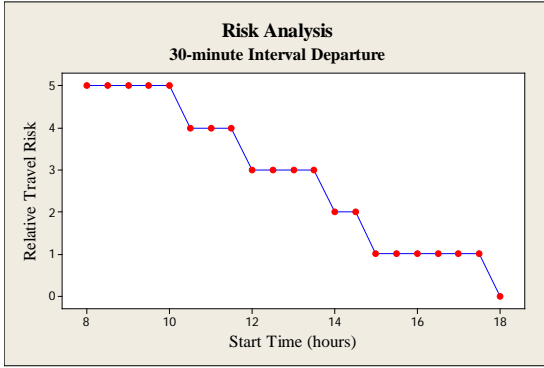

Figure 71. Graphic presenting the relative travel risk throughout the complete route, with 30-minute interval departure.

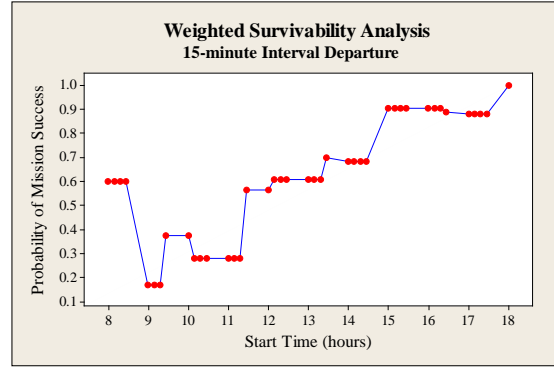

Figure 72. Graphic presenting the boat capability of surviving the supply mission under tree absence throughout the complete route, emphasizing the importance of travel time, with 15-minute interval departure.

Figures 73, 74 and 75 present the input and outcome screenshots showing what data was placed as well as the result model. The existence of higher riverine arboreal biome produces larger shadow areas and, as a result, the risk level is null on all paths. The probability of mission success, is 100%. The four subsequent figures (76 to 79), graphically display the model behavior, exactly as it was expected.

| Nodes | D | M | S | D | M | S |
|-------------|----|-----|--------|-----|-----|--------|
| 1 Point 01 | -1 | -8 | -33.39 | -62 | -18 | -2.93 |
| 2 Point 02 | -1 | -8 | -56.77 | -62 | -20 | -10.73 |
| 3 Point 03 | -1 | -9 | -20.87 | -62 | -18 | -14.87 |
| 4 Point 04 | -1 | -10 | -10.27 | -62 | -16 | -27.98 |
| 5 Point 05 | -1 | -9 | -38.05 | -62 | -16 | -19.46 |
| 6 Point 06 | -1 | -8 | -30.17 | -62 | -15 | -30.58 |
| 7 Point 07 | -1 | -11 | -50.28 | -62 | -16 | -18.18 |
| 8 Point 08 | -1 | -9 | -50.01 | -62 | -14 | -17.58 |
| 9 Point 09 | -1 | -8 | -47.25 | -62 | -14 | -2.39 |
| 10 Point 10 | -1 | -10 | -57.86 | -62 | -14 | -29.54 |
| 11 Point 11 | -1 | -12 | -12.48 | -62 | -14 | -38.15 |
| 12 Point 12 | -1 | -10 | -17.27 | -62 | -12 | -42.80 |
| 13 Point 13 | -1 | -12 | -48.08 | -62 | -14 | -53.47 |
| 14 Point 14 | -1 | -13 | -35.56 | -62 | -15 | -2.00 |
| 15 Point 15 | -1 | -14 | -19.68 | -62 | -14 | -45.10 |
| 16 Point 16 | -1 | -14 | -19.83 | -62 | -12 | -53.10 |
| 17 Point 17 | -1 | -13 | -57.84 | -62 | -12 | -19.15 |
| 18 Point 18 | -1 | -11 | -47.40 | -62 | -11 | -31.28 |
| 19 Point 19 | -1 | -15 | -58.30 | -62 | -12 | -58.26 |
| 20 Point 20 | -1 | -9 | -41.88 | -62 | -10 | -8.37 |
| 21 Point 21 | -1 | -18 | -9.03 | -62 | -11 | -52.29 |
| 22 Point 22 | -1 | -15 | -29.66 | -62 | -10 | -32.27 |
| 23 Point 23 | -1 | -14 | -42.42 | -62 | -7 | -35.71 |
| 24 Point 24 | -1 | -11 | -37.50 | -62 | -6 | -56.56 |

Figure 73. Input Spreadsheet's Excel screenshot, considering 30-minute interval departure.

| Path | Risk | Time | Survivability | Weighted Survivability |
|-------|--------|---------|---------------|------------------------|
| 8:00 | 0.0000 | 1.8017 | 1.0000 | 1.8017 |
| 8:30 | 0.0000 | 1.1358 | 1.0000 | 1.1358 |
| 9:00 | 0.0000 | 3.0245 | 1.0000 | 3.0245 |
| 9:30 | 0.0000 | 1.9066 | 1.0000 | 1.9066 |
| 10:00 | 0.0000 | 1.3999 | 1.0000 | 1.3999 |
| 10:30 | 0.0000 | 1.2574 | 1.0000 | 1.2574 |
| 11:00 | 0.0000 | 0.0000 | 1.0000 | 0.0000 |
| 11:30 | 0.0000 | 10.5259 | 1.0000 | 1.0000 |
| 12:00 | 0.0000 | 10.5259 | 1.0000 | 1.0000 |
| 12:30 | 0.0000 | 10.5259 | 1.0000 | 1.0000 |
| 13:00 | 0.0000 | 10.5259 | 1.0000 | 1.0000 |
| 13:30 | 0.0000 | 1.8017 | 1.0000 | 1.8017 |
| 14:00 | 0.0000 | 1.1358 | 1.0000 | 1.1358 |
| 14:30 | 0.0000 | 3.0245 | 1.0000 | 3.0245 |
| 15:00 | 0.0000 | 1.9066 | 1.0000 | 1.9066 |
| 15:30 | 0.0000 | 1.3999 | 1.0000 | 1.3999 |
| 16:00 | 0.0000 | 1.2574 | 1.0000 | 1.2574 |
| 16:30 | 0.0000 | 0.0000 | 1.0000 | 0.0000 |
| 17:00 | 0.0000 | 10.5259 | 1.0000 | 1.0000 |
| 17:30 | 0.0000 | 10.5259 | 1.0000 | 1.0000 |
| 18:00 | 0.0000 | 10.5259 | 1.0000 | 1.0000 |

Figure 74. Output Spreadsheet's Excel screenshot, considering 30-minute interval departure.

| Fastest Path | | | | | | | | | | | | | | | |
|--------------|------|--------|---------------|------------------------|------------------------|--|--|--|--|--|------------|--------|---------|---------------|------------------------|
| Fastest Path | Risk | Time | Survivability | Weighted Survivability | | | | | | | Start Time | Risk | Time | Survivability | Weighted Survivability |
| 1 | | | | | | | | | | | 8:00 | 0.0000 | 10.5259 | 1.0000 | 1.0000 |
| 2 | 38 | 0.0000 | 1.8017 | 1.0000 | 1.8017 | | | | | | 8:15 | 0.0000 | 10.5259 | 1.0000 | 1.0000 |
| 3 | 32 | 0.0000 | 1.1358 | 1.0000 | 1.1358 | | | | | | 8:30 | 0.0000 | 10.5259 | 1.0000 | 1.0000 |
| 4 | 23 | 0.0000 | 3.0245 | 1.0000 | 3.0245 | | | | | | 8:45 | 0.0000 | 10.5259 | 1.0000 | 1.0000 |
| 5 | 18 | 0.0000 | 1.9066 | 1.0000 | 1.9066 | | | | | | 9:00 | 0.0000 | 10.5259 | 1.0000 | 1.0000 |
| 6 | 10 | 0.0000 | 1.3999 | 1.0000 | 1.3999 | | | | | | 9:15 | 0.0000 | 10.5259 | 1.0000 | 1.0000 |
| 7 | 5 | 0.0000 | 1.2574 | 1.0000 | 1.2574 | | | | | | 9:30 | 0.0000 | 10.5259 | 1.0000 | 1.0000 |
| 8 | 1 | 0.0000 | 0.0000 | 1.0000 | 0.0000 | | | | | | 9:45 | 0.0000 | 10.5259 | 1.0000 | 1.0000 |
| 9 | | | | | | | | | | | 10:00 | 0.0000 | 10.5259 | 1.0000 | 1.0000 |
| 10 | | 0.0000 | 10.5259 | 1.0000 | 1.0000 | | | | | | 10:15 | 0.0000 | 10.5259 | 1.0000 | 1.0000 |
| 11 | | | | | | | | | | | 10:30 | 0.0000 | 10.5259 | 1.0000 | 1.0000 |
| 12 | Path | Risk | Time | Survivability | Weighted Survivability | | | | | | 10:45 | 0.0000 | 10.5259 | 1.0000 | 1.0000 |
| 13 | 38 | 0.0000 | 1.8017 | 1.0000 | 1.8017 | | | | | | 11:00 | 0.0000 | 10.5259 | 1.0000 | 1.0000 |
| 14 | 32 | 0.0000 | 1.1358 | 1.0000 | 1.1358 | | | | | | 11:15 | 0.0000 | 10.5259 | 1.0000 | 1.0000 |
| 15 | 23 | 0.0000 | 3.0245 | 1.0000 | 3.0245 | | | | | | 11:30 | 0.0000 | 10.5259 | 1.0000 | 1.0000 |
| 16 | 18 | 0.0000 | 1.9066 | 1.0000 | 1.9066 | | | | | | 11:45 | 0.0000 | 10.5259 | 1.0000 | 1.0000 |
| 17 | 10 | 0.0000 | 1.3999 | 1.0000 | 1.3999 | | | | | | 12:00 | 0.0000 | 10.5259 | 1.0000 | 1.0000 |
| 18 | 5 | 0.0000 | 1.2574 | 1.0000 | 1.2574 | | | | | | 12:15 | 0.0000 | 10.5259 | 1.0000 | 1.0000 |
| 19 | 1 | 0.0000 | 0.0000 | 1.0000 | 0.0000 | | | | | | 12:30 | 0.0000 | 10.5259 | 1.0000 | 1.0000 |
| 20 | | | | | | | | | | | 12:45 | 0.0000 | 10.5259 | 1.0000 | 1.0000 |
| 21 | | 0.0000 | 10.5259 | 1.0000 | 1.0000 | | | | | | 13:00 | 0.0000 | 10.5259 | 1.0000 | 1.0000 |
| 22 | | | | | | | | | | | 13:15 | 0.0000 | 10.5259 | 1.0000 | 1.0000 |
| 23 | Path | Risk | Time | Survivability | Weighted Survivability | | | | | | 13:30 | 0.0000 | 10.5259 | 1.0000 | 1.0000 |
| 24 | 38 | 0.0000 | 1.8017 | 1.0000 | 1.8017 | | | | | | 13:45 | 0.0000 | 10.5259 | 1.0000 | 1.0000 |
| 25 | 32 | 0.0000 | 1.1358 | 1.0000 | 1.1358 | | | | | | 14:00 | 0.0000 | 10.5259 | 1.0000 | 1.0000 |
| 26 | 23 | 0.0000 | 3.0245 | 1.0000 | 3.0245 | | | | | | 14:15 | 0.0000 | 10.5259 | 1.0000 | 1.0000 |
| 27 | 18 | 0.0000 | 1.9066 | 1.0000 | 1.9066 | | | | | | 14:30 | 0.0000 | 10.5259 | 1.0000 | 1.0000 |
| 28 | 10 | 0.0000 | 1.3999 | 1.0000 | 1.3999 | | | | | | 14:45 | 0.0000 | 10.5259 | 1.0000 | 1.0000 |
| 29 | 5 | 0.0000 | 1.2574 | 1.0000 | 1.2574 | | | | | | 15:00 | 0.0000 | 10.5259 | 1.0000 | 1.0000 |
| 30 | 1 | 0.0000 | 0.0000 | 1.0000 | 0.0000 | | | | | | 15:15 | 0.0000 | 10.5259 | 1.0000 | 1.0000 |
| 31 | | | | | | | | | | | 15:30 | 0.0000 | 10.5259 | 1.0000 | 1.0000 |
| 32 | | 0.0000 | 10.5259 | 1.0000 | 1.0000 | | | | | | 15:45 | 0.0000 | 10.5259 | 1.0000 | 1.0000 |
| 33 | | | | | | | | | | | 16:00 | 0.0000 | 10.5259 | 1.0000 | 1.0000 |
| 34 | Path | Risk | Time | Survivability | Weighted Survivability | | | | | | 16:15 | 0.0000 | 10.5259 | 1.0000 | 1.0000 |
| 35 | 38 | 0.0000 | 1.8017 | 1.0000 | 1.8017 | | | | | | 16:30 | 0.0000 | 10.5259 | 1.0000 | 1.0000 |
| 36 | 32 | 0.0000 | 1.1358 | 1.0000 | 1.1358 | | | | | | 16:45 | 0.0000 | 10.5259 | 1.0000 | 1.0000 |
| 37 | 23 | 0.0000 | 3.0245 | 1.0000 | 3.0245 | | | | | | 17:00 | 0.0000 | 10.5259 | 1.0000 | 1.0000 |
| 38 | 18 | 0.0000 | 1.9066 | 1.0000 | 1.9066 | | | | | | 17:15 | 0.0000 | 10.5259 | 1.0000 | 1.0000 |
| 39 | 10 | 0.0000 | 1.3999 | 1.0000 | 1.3999 | | | | | | 17:30 | 0.0000 | 10.5259 | 1.0000 | 1.0000 |
| 40 | 5 | 0.0000 | 1.2574 | 1.0000 | 1.2574 | | | | | | 17:45 | 0.0000 | 10.5259 | 1.0000 | 1.0000 |
| 41 | 1 | 0.0000 | 0.0000 | 1.0000 | 0.0000 | | | | | | 18:00 | 0.0000 | 10.5259 | 1.0000 | 1.0000 |
| 42 | | | | | | | | | | | | | | | |
| 43 | | 0.0000 | 10.5259 | 1.0000 | 1.0000 | | | | | | | | | | |

Figure 75. Output Spreadsheet's Excel screenshot, considering 15-minute interval departure.

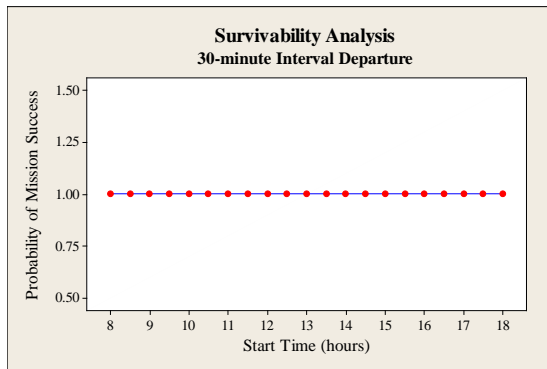

Figure 76. Graphic presenting the boat capability of surviving the supply mission under higher tree path condition throughout the complete route, with 30-minute interval departure.

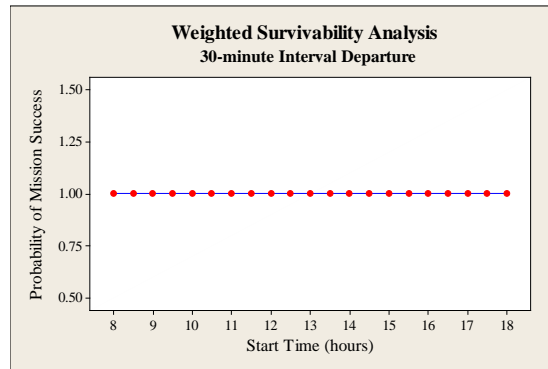

Figure 77. Graphic presenting the boat capability of surviving the supply mission under higher tree path condition throughout the complete route, emphasizing the importance of travel time, with 30-minute interval departure.

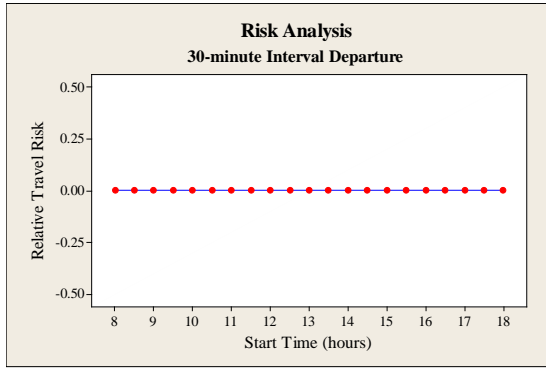

Figure 78. Graphic presenting the relative travel risk under higher tree path condition throughout the complete route, with 30-minute interval departure.

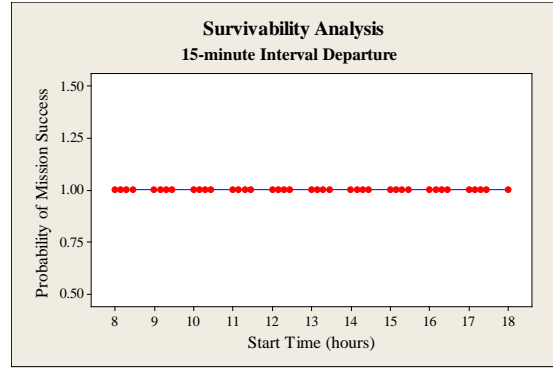

Figure 79. Graphic presenting the boat capability of surviving the supply mission under higher tree path condition throughout the complete route, emphasizing the importance of travel time, with 15-minute interval departure.

Cause-Effect Graphing

The second verification method compares the cause-and-effect relationships in the real world to those in the conceptual model (Dasso and Funes, 2007:172; Haug and others, 2001:47). Causes are events or conditions that may occur in the real world and the effects are the consequences or state changes that result from the causes. In this study, the most significant parameters that affect the enemy exposure level (either increase or decrease) are boat speed and width, as well as the actual riverine forest configuration on the network.

Changing boat speed gradually (figures 80 to 84) from small velocities to large ones, it is possible to identify smaller variation on both the travel risk and move survivability (figures 85 to 100). This fact is due to, outside the first hours of the morning as well as the lasts ones of the afternoon a boat's need to transverse the predefined network completely from node 1 to node 38 regardless of its speed. Since the move becomes faster it attains high-level risk locations earlier than if it was slower. Therefore,

considering the larger distances between each node, the unique way to perform a zero-risk travel is to move extremely fast over the river which, as a result, will require powerful and noisy engine. This results in unfeasible conduct for a stealthy movement.

The screenshot shows an Excel spreadsheet with the following data:

- time-zone: -3 daylight Saving, 0
- Sunrise: 7.218 hours
- Solarnoon: 13.272 hours
- Sunset: 19.326 hours
- Leap Year: 0
- Boat speed: 1.864113 miles/hour (highlighted in red)
- Ratio of the Earth: 3,963.17 miles
- Riverine forest height: 0.0062 miles, 32.888 feet, 10 meters, 393.7 inch
- geographic latitude and longitude for 24 points (Point 01 to Point 24).

Figure 80. Input Spreadsheet's Excel screenshot, with rate 1.86 miles per hour.

The screenshot shows an Excel spreadsheet titled "Fastest Path" with the following data:

- Columns: Path, Risk, Time, Survivability, Weighted Survivability, Start Time, Risk, Time, Survivability, Weighted Survivability.
- Row 2: Path 38, Risk 0.7729, Time 1.8017, Survivability 0.2271, Weighted Survivability 0.4091.
- Row 3: Path 32, Risk 0.0000, Time 1.1358, Survivability 1.0000, Weighted Survivability 1.1358.
- Row 4: Path 23, Risk 0.0000, Time 3.0245, Survivability 1.0000, Weighted Survivability 3.0245.
- Row 5: Path 18, Risk 0.0000, Time 1.9066, Survivability 1.0000, Weighted Survivability 1.9066.
- Row 6: Path 10, Risk 0.0000, Time 1.3999, Survivability 1.0000, Weighted Survivability 1.3999.
- Row 7: Path 5, Risk 0.0000, Time 1.2574, Survivability 1.0000, Weighted Survivability 1.2574.
- Row 8: Path 1, Risk 0.0000, Time 0.0000, Survivability 1.0000, Weighted Survivability 0.0000.
- Row 9: Path 7, Risk 0.0000, Time 10.5259, Survivability 0.2271, Weighted Survivability 0.8677.
- Row 10: Path 8, Risk 0.0000, Time 0.0000, Survivability 1.0000, Weighted Survivability 0.0000.
- Row 11: Path 8, Risk 0.0000, Time 0.4593, Survivability 1.0000, Weighted Survivability 0.4593.
- Row 12: Path 38, Risk 0.0000, Time 0.4593, Survivability 1.0000, Weighted Survivability 0.4593.
- Row 13: Path 37, Risk 0.0000, Time 0.8324, Survivability 1.0000, Weighted Survivability 0.8324.
- Row 14: Path 33, Risk 0.0000, Time 0.7919, Survivability 1.0000, Weighted Survivability 0.7919.
- Row 15: Path 32, Risk 0.0000, Time 1.1358, Survivability 1.0000, Weighted Survivability 1.1358.
- Row 16: Path 23, Risk 0.0000, Time 3.0245, Survivability 1.0000, Weighted Survivability 3.0245.
- Row 17: Path 18, Risk 0.0000, Time 1.9066, Survivability 1.0000, Weighted Survivability 1.9066.
- Row 18: Path 10, Risk 0.0000, Time 1.3999, Survivability 1.0000, Weighted Survivability 1.3999.
- Row 19: Path 5, Risk 0.0000, Time 1.2574, Survivability 1.0000, Weighted Survivability 1.2574.
- Row 20: Path 1, Risk 0.0000, Time 0.0000, Survivability 1.0000, Weighted Survivability 0.0000.
- Row 21: Path 7, Risk 0.0000, Time 10.5259, Survivability 1.0000, Weighted Survivability 1.0000.
- Row 22: Path 8, Risk 0.0000, Time 0.0000, Survivability 1.0000, Weighted Survivability 0.0000.
- Row 23: Path 8, Risk 0.0000, Time 0.4593, Survivability 1.0000, Weighted Survivability 0.4593.
- Row 24: Path 37, Risk 0.0000, Time 0.8324, Survivability 1.0000, Weighted Survivability 0.8324.
- Row 25: Path 33, Risk 0.0000, Time 0.7919, Survivability 1.0000, Weighted Survivability 0.7919.
- Row 26: Path 32, Risk 0.0000, Time 1.1358, Survivability 1.0000, Weighted Survivability 1.1358.
- Row 27: Path 23, Risk 0.0000, Time 3.0245, Survivability 1.0000, Weighted Survivability 3.0245.
- Row 28: Path 18, Risk 0.0000, Time 1.9066, Survivability 1.0000, Weighted Survivability 1.9066.
- Row 29: Path 10, Risk 0.0000, Time 1.3999, Survivability 1.0000, Weighted Survivability 1.3999.
- Row 30: Path 5, Risk 0.0000, Time 1.2574, Survivability 1.0000, Weighted Survivability 1.2574.

Figure 81. Output Spreadsheet's Excel screenshot, with rate 1.86 miles per hour.

| Fastest Path | | | | | | | | | | | | | | | | |
|--------------|------|--------|---------------|------------------------|------------------------|---|---|---|------------|--------|---------|---------------|------------------------|---|---|---|
| A | B | C | D | E | F | G | H | I | J | K | L | M | N | O | P | Q |
| Fastest Path | Risk | Time | Survivability | Weighted Survivability | | | | | Start Time | Risk | Time | Survivability | Weighted Survivability | | | |
| 1 | | | | | | | | | | | | | | | | |
| 2 | 38 | 0.7729 | 1.0810 | 0.2271 | 0.2455 | | | | 8:00 | 0.0000 | 6.4848 | 1.0000 | 1.0000 | | | |
| 3 | 32 | 0.0000 | 0.6815 | 1.0000 | 0.6815 | | | | 8:30 | 0.0000 | 6.4848 | 1.0000 | 1.0000 | | | |
| 4 | 23 | 0.0000 | 1.8147 | 1.0000 | 1.8147 | | | | 9:00 | 0.0000 | 18.2180 | 1.0000 | 1.0000 | | | |
| 5 | 18 | 0.0000 | 1.1440 | 1.0000 | 1.1440 | | | | 9:30 | 0.0000 | 12.4384 | 1.0000 | 1.0000 | | | |
| 6 | 10 | 0.0000 | 0.8400 | 1.0000 | 0.8400 | | | | 10:00 | 0.0000 | 12.4384 | 1.0000 | 1.0000 | | | |
| 7 | 5 | 0.0000 | 0.7545 | 1.0000 | 0.7545 | | | | 10:30 | 0.0000 | 12.6076 | 1.0000 | 1.0000 | | | |
| 8 | 1 | 0.0000 | 0.0000 | 1.0000 | 0.0000 | | | | 11:00 | 0.6178 | 12.6988 | 0.3822 | 0.9523 | | | |
| 9 | | | | | | | | | 11:30 | 0.8539 | 12.4653 | 0.4105 | 0.9412 | | | |
| 10 | | 0.7729 | 6.3156 | 0.2271 | 0.8677 | | | | 12:00 | 0.9626 | 12.3785 | 0.3163 | 0.9150 | | | |
| 11 | | | | | | | | | 12:30 | 1.8767 | 6.3492 | 0.0799 | 0.6748 | | | |
| 12 | Path | Risk | Time | Survivability | Weighted Survivability | | | | 13:00 | 0.2937 | 6.3492 | 0.7313 | 0.9455 | | | |
| 13 | 38 | 0.0000 | 0.2756 | 1.0000 | 0.2756 | | | | 13:30 | 1.1259 | 6.7551 | 0.2743 | 0.8437 | | | |
| 14 | 37 | 0.0000 | 0.4995 | 1.0000 | 0.4995 | | | | 14:00 | 2.0493 | 7.2673 | 0.0625 | 0.7418 | | | |
| 15 | 33 | 0.0000 | 0.4752 | 1.0000 | 0.4752 | | | | 14:30 | 0.1645 | 8.2059 | 0.8355 | 0.9839 | | | |
| 16 | 32 | 0.0000 | 0.6815 | 1.0000 | 0.6815 | | | | 15:00 | 0.2991 | 8.4875 | 0.7009 | 0.9717 | | | |
| 17 | 23 | 0.0000 | 1.8147 | 1.0000 | 1.8147 | | | | 15:30 | 0.0000 | 6.3156 | 1.0000 | 1.0000 | | | |
| 18 | 18 | 0.0000 | 1.1440 | 1.0000 | 1.1440 | | | | 16:00 | 0.0000 | 6.3156 | 1.0000 | 1.0000 | | | |
| 19 | 10 | 0.0000 | 0.8400 | 1.0000 | 0.8400 | | | | 16:30 | 0.0000 | 6.3156 | 1.0000 | 1.0000 | | | |
| 20 | 5 | 0.0000 | 0.7545 | 1.0000 | 0.7545 | | | | 17:00 | 0.0000 | 8.2059 | 1.0000 | 1.0000 | | | |
| 21 | 1 | 0.0000 | 0.0000 | 1.0000 | 0.0000 | | | | 17:30 | 0.0000 | 6.3156 | 1.0000 | 1.0000 | | | |
| 22 | | | | | | | | | 18:00 | 0.0000 | 6.3156 | 1.0000 | 1.0000 | | | |
| 23 | | 0.0000 | 6.4848 | 1.0000 | 1.0000 | | | | | | | | | | | |
| 24 | Path | Risk | Time | Survivability | Weighted Survivability | | | | | | | | | | | |
| 25 | 8:30 | | | | | | | | | | | | | | | |
| 26 | 38 | 0.0000 | 0.2756 | 1.0000 | 0.2756 | | | | | | | | | | | |
| 27 | 37 | 0.0000 | 0.4995 | 1.0000 | 0.4995 | | | | | | | | | | | |
| 28 | 33 | 0.0000 | 0.4752 | 1.0000 | 0.4752 | | | | | | | | | | | |
| 29 | 32 | 0.0000 | 0.6815 | 1.0000 | 0.6815 | | | | | | | | | | | |
| 30 | 23 | 0.0000 | 1.8147 | 1.0000 | 1.8147 | | | | | | | | | | | |
| 31 | 18 | 0.0000 | 1.1440 | 1.0000 | 1.1440 | | | | | | | | | | | |
| 32 | 10 | 0.0000 | 0.8400 | 1.0000 | 0.8400 | | | | | | | | | | | |
| 33 | 5 | 0.0000 | 0.7545 | 1.0000 | 0.7545 | | | | | | | | | | | |

Figure 82. Output Spreadsheet's Excel screenshot, with rate 3.11 miles per hour.

| Fastest Path | | | | | | | | | | | | | | | | |
|--------------|------|--------|---------------|------------------------|------------------------|---|---|---|------------|--------|--------|---------------|------------------------|---|---|---|
| A | B | C | D | E | F | G | H | I | J | K | L | M | N | O | P | Q |
| Fastest Path | Risk | Time | Survivability | Weighted Survivability | | | | | Start Time | Risk | Time | Survivability | Weighted Survivability | | | |
| 1 | | | | | | | | | | | | | | | | |
| 2 | 38 | 0.7729 | 0.5405 | 0.2271 | 0.1227 | | | | 8:00 | 0.0000 | 3.2424 | 1.0000 | 1.0000 | | | |
| 3 | 32 | 0.0000 | 0.3407 | 1.0000 | 0.3407 | | | | 8:30 | 0.0000 | 3.2424 | 1.0000 | 1.0000 | | | |
| 4 | 23 | 0.0000 | 0.9073 | 1.0000 | 0.9073 | | | | 9:00 | 0.0000 | 3.2424 | 1.0000 | 1.0000 | | | |
| 5 | 18 | 0.0000 | 0.5720 | 1.0000 | 0.5720 | | | | 9:30 | 0.1424 | 3.1578 | 0.8576 | 0.9756 | | | |
| 6 | 10 | 0.0000 | 0.4200 | 1.0000 | 0.4200 | | | | 10:00 | 0.0773 | 3.1578 | 0.9227 | 0.9868 | | | |
| 7 | 5 | 0.0000 | 0.3772 | 1.0000 | 0.3772 | | | | 10:30 | 0.0286 | 3.1578 | 0.9714 | 0.9951 | | | |
| 8 | 1 | 0.0000 | 0.0000 | 1.0000 | 0.0000 | | | | 11:00 | 0.7771 | 3.1578 | 0.2310 | 0.8594 | | | |
| 9 | | | | | | | | | 11:30 | 0.8905 | 3.1732 | 0.3134 | 0.8742 | | | |
| 10 | | 0.7729 | 3.1578 | 0.2271 | 0.8677 | | | | 12:00 | 2.0827 | 3.6846 | 0.0000 | 0.7771 | | | |
| 11 | | | | | | | | | 12:30 | 1.8767 | 3.1746 | 0.0799 | 0.6748 | | | |
| 12 | Path | Risk | Time | Survivability | Weighted Survivability | | | | 13:00 | 0.4222 | 3.1746 | 0.6373 | 0.9236 | | | |
| 13 | 38 | 0.0000 | 0.1378 | 1.0000 | 0.1378 | | | | 13:30 | 1.4276 | 3.6006 | 0.1952 | 0.7787 | | | |
| 14 | 37 | 0.0000 | 0.2497 | 1.0000 | 0.2497 | | | | 14:00 | 2.8934 | 6.4795 | 0.0097 | 0.7005 | | | |
| 15 | 33 | 0.0000 | 0.2376 | 1.0000 | 0.2376 | | | | 14:30 | 0.4117 | 8.6237 | 0.6290 | 0.9794 | | | |
| 16 | 32 | 0.0000 | 0.3407 | 1.0000 | 0.3407 | | | | 15:00 | 0.5944 | 4.2438 | 0.4939 | 0.9403 | | | |
| 17 | 23 | 0.0000 | 0.9073 | 1.0000 | 0.9073 | | | | 15:30 | 0.0000 | 6.3038 | 1.0000 | 1.0000 | | | |
| 18 | 18 | 0.0000 | 0.5720 | 1.0000 | 0.5720 | | | | 16:00 | 0.0000 | 3.4075 | 1.0000 | 1.0000 | | | |
| 19 | 10 | 0.0000 | 0.4200 | 1.0000 | 0.4200 | | | | 16:30 | 0.0000 | 3.4075 | 1.0000 | 1.0000 | | | |
| 20 | 5 | 0.0000 | 0.3772 | 1.0000 | 0.3772 | | | | 17:00 | 0.0000 | 4.1029 | 1.0000 | 1.0000 | | | |
| 21 | 1 | 0.0000 | 0.0000 | 1.0000 | 0.0000 | | | | 17:30 | 0.0000 | 3.1578 | 1.0000 | 1.0000 | | | |
| 22 | | | | | | | | | 18:00 | 0.0000 | 3.1578 | 1.0000 | 1.0000 | | | |
| 23 | | 0.0000 | 3.2424 | 1.0000 | 1.0000 | | | | | | | | | | | |
| 24 | Path | Risk | Time | Survivability | Weighted Survivability | | | | | | | | | | | |
| 25 | 8:30 | | | | | | | | | | | | | | | |
| 26 | 38 | 0.0000 | 0.1378 | 1.0000 | 0.1378 | | | | | | | | | | | |
| 27 | 37 | 0.0000 | 0.2497 | 1.0000 | 0.2497 | | | | | | | | | | | |
| 28 | 33 | 0.0000 | 0.2376 | 1.0000 | 0.2376 | | | | | | | | | | | |
| 29 | 32 | 0.0000 | 0.3407 | 1.0000 | 0.3407 | | | | | | | | | | | |
| 30 | 23 | 0.0000 | 0.9073 | 1.0000 | 0.9073 | | | | | | | | | | | |
| 31 | 18 | 0.0000 | 0.5720 | 1.0000 | 0.5720 | | | | | | | | | | | |
| 32 | 10 | 0.0000 | 0.4200 | 1.0000 | 0.4200 | | | | | | | | | | | |
| 33 | 5 | 0.0000 | 0.3772 | 1.0000 | 0.3772 | | | | | | | | | | | |

Figure 83. Output Spreadsheet's Excel screenshot, with rate 6.21 miles per hour.

| Fastest Path | | | | | | | | | | | | | | | |
|--------------|------|--------|---------------|------------------------|------------------------|------------|--------|--------|---------------|------------------------|--|--|--|--|--|
| Fastest Path | Risk | Time | Survivability | Weighted Survivability | | Start Time | Risk | Time | Survivability | Weighted Survivability | | | | | |
| 1 | | | | | | | | | | | | | | | |
| 2 | 33 | 0.4029 | 0.3603 | 0.5971 | 0.2152 | 8:30 | 0.0000 | 2.1616 | 1.0000 | 1.0000 | | | | | |
| 3 | 32 | 0.0000 | 0.2272 | 1.0000 | 0.2272 | 9:00 | 0.0000 | 2.1616 | 1.0000 | 1.0000 | | | | | |
| 4 | 23 | 0.0000 | 0.6049 | 1.0000 | 0.6049 | 9:30 | 0.1424 | 2.1052 | 0.8576 | 0.9756 | | | | | |
| 5 | 18 | 0.0000 | 0.3813 | 1.0000 | 0.3813 | 10:00 | 0.0773 | 2.1052 | 0.9227 | 0.9868 | | | | | |
| 6 | 10 | 0.0000 | 0.2800 | 1.0000 | 0.2800 | 10:30 | 0.0286 | 2.1052 | 0.9714 | 0.9951 | | | | | |
| 7 | 5 | 0.0000 | 0.2515 | 1.0000 | 0.2515 | 11:00 | 0.7771 | 2.1052 | 0.2310 | 0.8594 | | | | | |
| 8 | 1 | 0.0000 | 0.0000 | 1.0000 | 0.0000 | 11:30 | 0.8965 | 2.1155 | 0.3134 | 0.8742 | | | | | |
| 9 | | | | | | 12:00 | 2.8827 | 2.4564 | 0.0000 | 0.7771 | | | | | |
| 10 | | 0.4029 | 2.1052 | 0.5971 | 0.9310 | 12:30 | 1.8767 | 2.1164 | 0.0799 | 0.6748 | | | | | |
| 11 | | | | | | 13:00 | 0.4222 | 2.1164 | 0.6373 | 0.9236 | | | | | |
| 12 | Path | Risk | Time | Survivability | Weighted Survivability | 13:30 | 1.4276 | 2.3871 | 0.1952 | 0.7787 | | | | | |
| 13 | 38 | 0.0000 | 0.0919 | 1.0000 | 0.0919 | 14:00 | 3.0613 | 2.1164 | 0.0080 | 0.4787 | | | | | |
| 14 | 37 | 0.0000 | 0.1665 | 1.0000 | 0.1665 | 14:30 | 1.0089 | 3.3320 | 0.2534 | 0.8550 | | | | | |
| 15 | 33 | 0.0000 | 0.1584 | 1.0000 | 0.1584 | 15:00 | 0.5944 | 2.8292 | 0.4839 | 0.9403 | | | | | |
| 16 | 32 | 0.0000 | 0.2272 | 1.0000 | 0.2272 | 15:30 | 0.0000 | 5.3775 | 1.0000 | 1.0000 | | | | | |
| 17 | 23 | 0.0000 | 0.6049 | 1.0000 | 0.6049 | 16:00 | 0.0000 | 4.1461 | 1.0000 | 1.0000 | | | | | |
| 18 | 18 | 0.0000 | 0.3813 | 1.0000 | 0.3813 | 16:30 | 0.0000 | 2.2717 | 1.0000 | 1.0000 | | | | | |
| 19 | 10 | 0.0000 | 0.2800 | 1.0000 | 0.2800 | 17:00 | 0.0000 | 2.1616 | 1.0000 | 1.0000 | | | | | |
| 20 | 5 | 0.0000 | 0.2515 | 1.0000 | 0.2515 | 17:30 | 0.0000 | 2.1052 | 1.0000 | 1.0000 | | | | | |
| 21 | 1 | 0.0000 | 0.0000 | 1.0000 | 0.0000 | 18:00 | 0.0000 | 2.1052 | 1.0000 | 1.0000 | | | | | |
| 22 | | | | | | | | | | | | | | | |
| 23 | | 0.0000 | 2.1616 | 1.0000 | 1.0000 | | | | | | | | | | |
| 24 | Path | Risk | Time | Survivability | Weighted Survivability | | | | | | | | | | |
| 25 | 9:00 | | | | | | | | | | | | | | |
| 26 | 38 | 0.0000 | 0.0919 | 1.0000 | 0.0919 | | | | | | | | | | |
| 27 | 37 | 0.0000 | 0.1665 | 1.0000 | 0.1665 | | | | | | | | | | |
| 28 | 33 | 0.0000 | 0.1584 | 1.0000 | 0.1584 | | | | | | | | | | |
| 29 | 32 | 0.0000 | 0.2272 | 1.0000 | 0.2272 | | | | | | | | | | |
| 30 | 23 | 0.0000 | 0.6049 | 1.0000 | 0.6049 | | | | | | | | | | |
| 31 | 18 | 0.0000 | 0.3813 | 1.0000 | 0.3813 | | | | | | | | | | |
| 32 | 10 | 0.0000 | 0.2800 | 1.0000 | 0.2800 | | | | | | | | | | |
| 33 | 5 | 0.0000 | 0.2515 | 1.0000 | 0.2515 | | | | | | | | | | |

Figure 84. Output Spreadsheet's Excel screenshot, with rate 9.32 miles per hour.

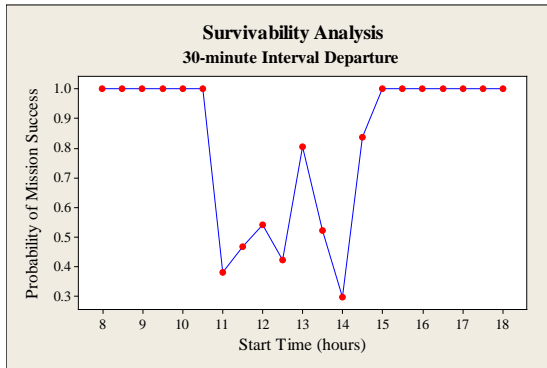

Figure 85. Graphic presenting the boat capability of surviving the supply mission, given rate 1.86 miles per hour, with 30-minute interval departure.

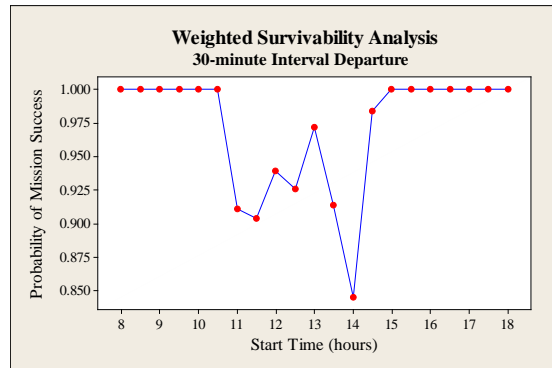

Figure 86. Graphic presenting the boat capability of surviving the supply mission, given rate 1.86 miles per hour, emphasizing the importance of travel time, with 30-minute interval departure.

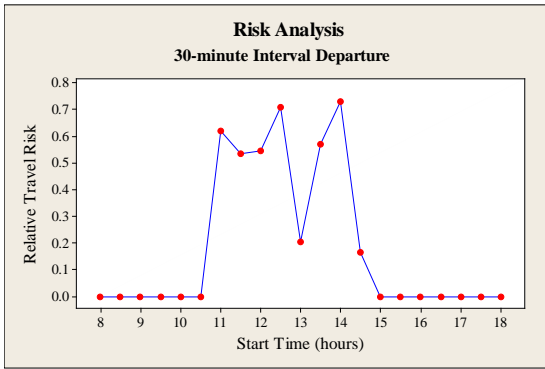

Figure 87. Graphic presenting the relative travel risk, given rate 1.86 miles per hour, with 30-minute interval departure.

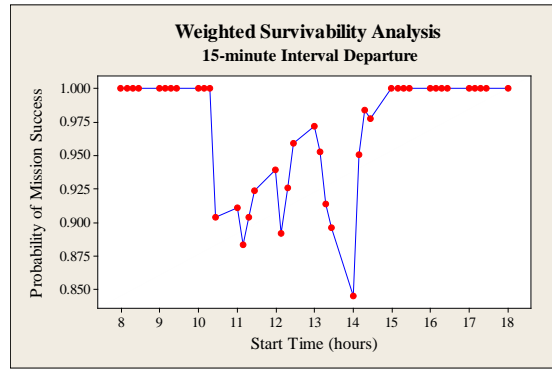

Figure 88. Graphic presenting the boat capability of surviving the supply mission, given rate 1.86 miles per hour, emphasizing the importance of travel time, with 15-minute interval departure.

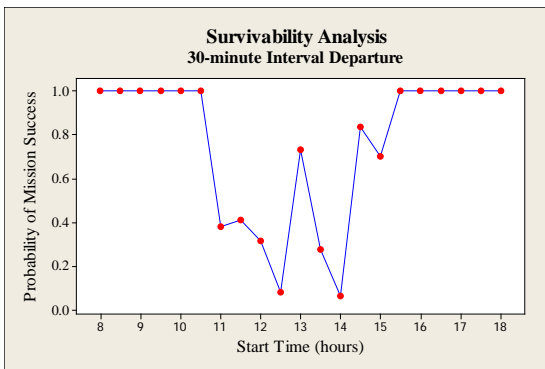

Figure 89. Graphic presenting the boat capability of surviving the supply mission, given rate 3.11 miles per hour, with 30-minute interval departure.

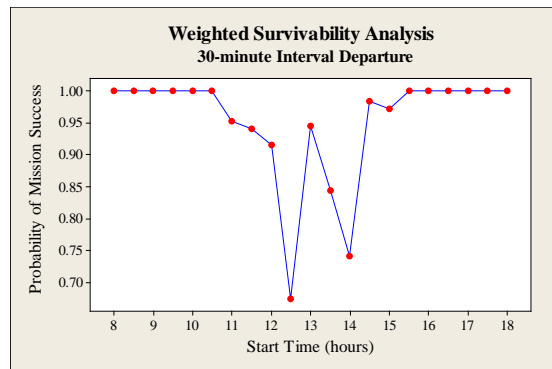

Figure 90. Graphic presenting the boat capability of surviving the supply mission, given rate 3.11 miles per hour, emphasizing the importance of travel time, with 30-minute interval departure.

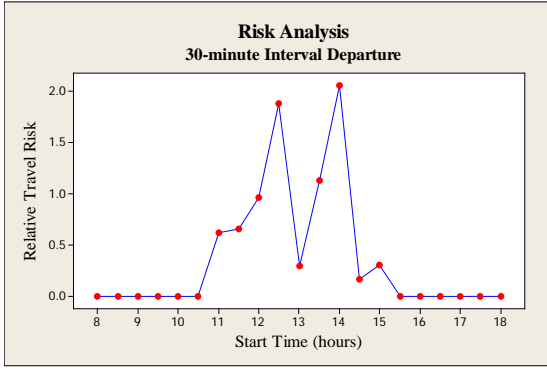

Figure 91. Graphic presenting the relative travel risk throughout the complete route, given rate 3.11 miles per hour, with 30-minute interval departure.

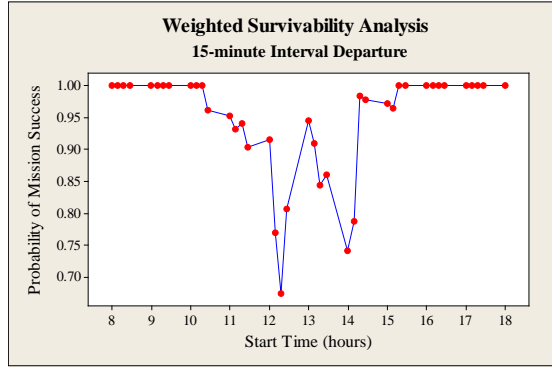

Figure 92. Graphic presenting the boat capability of surviving the supply mission, given rate 3.11 miles per hour, emphasizing the importance of travel time, with 15-minute interval departure.

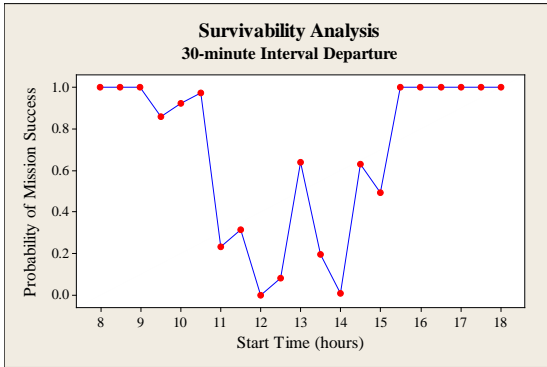

Figure 93. Graphic presenting the boat capability of surviving the supply mission, given rate 6.21 miles per hour, with 30-minute interval departure.

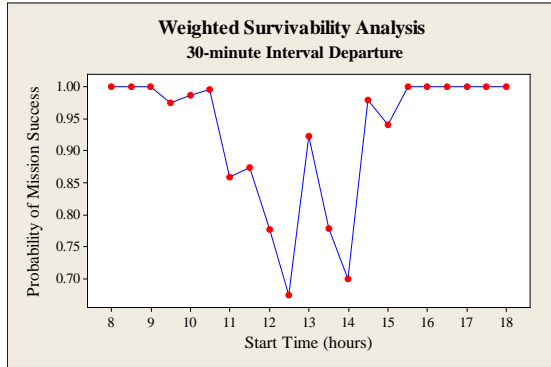

Figure 94. Graphic presenting the boat capability of surviving the supply mission, given rate 6.21 miles per hour, emphasizing the importance of travel time, with 30-minute interval departure.

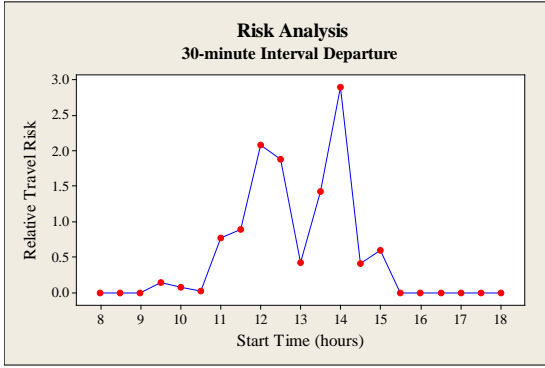

Figure 95. Graphic presenting the relative travel risk throughout the complete route, given rate 6.21 miles per hour, with 30-minute interval departure.

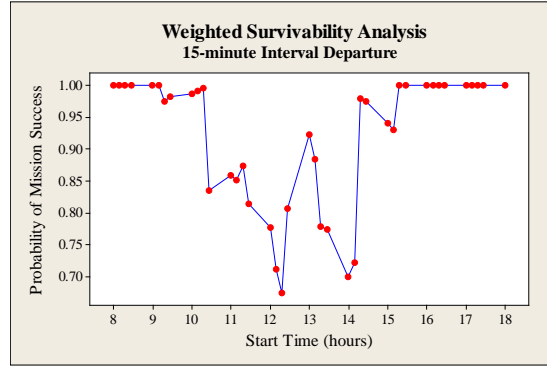

Figure 96. Graphic presenting the boat capability of surviving the supply mission, given rate 6.21 miles per hour, emphasizing the importance of travel time, with 15-minute interval departure.

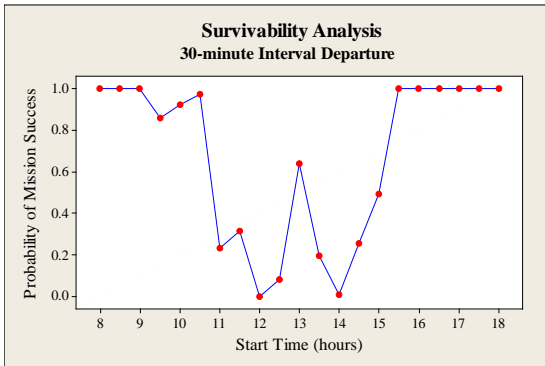

Figure 97. Graphic presenting the boat capability of surviving the supply mission, given rate 9.32 miles per hour, with 30-minute interval departure.

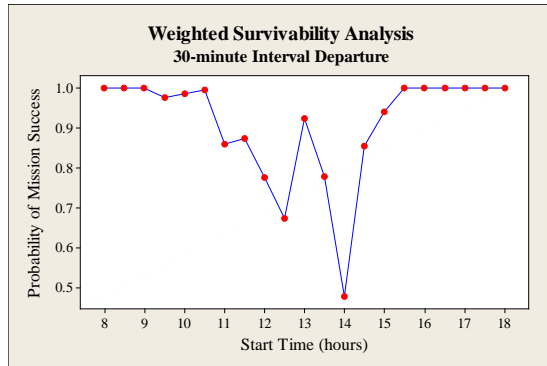

Figure 98. Graphic presenting the boat capability of surviving the supply mission, given rate 9.32 miles per hour, emphasizing the importance of travel time, with 30-minute interval departure.

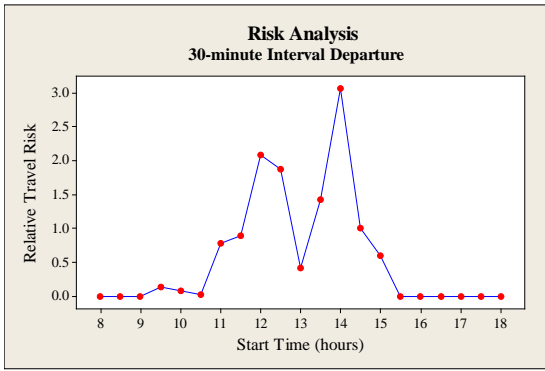

Figure 99. Graphic presenting the relative travel risk throughout the complete route, given rate 9.32 miles per hour, with 30-minute interval departure.

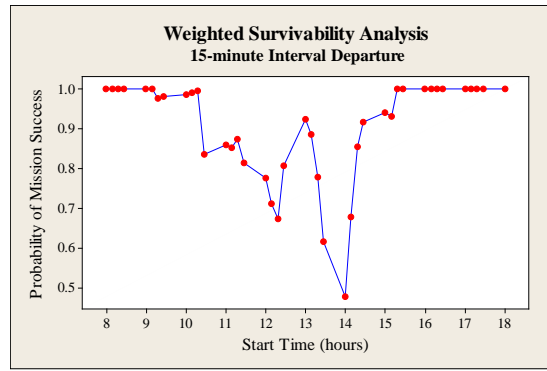

Figure 100. Graphic presenting the boat capability of surviving the supply mission, given rate 9.32 miles per hour, emphasizing the importance of travel time, with 15-minute interval departure.

Regardless of boat speed, any alteration on boat width (figure 101) causes significant variation on both the travel risk and travel survivability (figures 102 to 105). Analyzing the boat's behavior with distinct boat lengths highlights the increase in risk because of the enlarged exposure area figures (106 to 121).

| Nodes | geographic latitude | geographic longitude |
|-------------|---------------------|----------------------|
| 1 Point 01 | -1 -8 -33.39 | -62 -18 -2.93 |
| 2 Point 02 | -1 -8 -56.77 | -62 -20 -10.73 |
| 3 Point 03 | -1 -9 -20.87 | -62 -18 -14.87 |
| 4 Point 04 | -1 -10 -19.27 | -62 -16 -27.96 |
| 5 Point 05 | -1 -9 -38.05 | -62 -16 -19.46 |
| 6 Point 06 | -1 -8 -30.17 | -62 -15 -30.58 |
| 7 Point 07 | -1 -11 -50.28 | -62 -16 -18.18 |
| 8 Point 08 | -1 -9 -50.01 | -62 -14 -17.58 |
| 9 Point 09 | -1 -8 -47.25 | -62 -14 -2.39 |
| 10 Point 10 | -1 -10 -57.86 | -62 -14 -29.54 |
| 11 Point 11 | -1 -12 -12.48 | -62 -14 -38.15 |
| 12 Point 12 | -1 -10 -17.27 | -62 -12 -42.80 |
| 13 Point 13 | -1 -12 -48.08 | -62 -14 -53.47 |
| 14 Point 14 | -1 -13 -35.56 | -62 -15 -2.00 |
| 15 Point 15 | -1 -14 -19.68 | -62 -14 -45.10 |
| 16 Point 16 | -1 -14 -19.83 | -62 -12 -53.10 |
| 17 Point 17 | -1 -13 -57.84 | -62 -12 -19.15 |
| 18 Point 18 | -1 -11 -47.40 | -62 -11 -31.28 |
| 19 Point 19 | -1 -15 -58.30 | -62 -12 -58.26 |
| 20 Point 20 | -1 -9 -41.88 | -62 -10 -8.37 |
| 21 Point 21 | -1 -18 -9.03 | -62 -11 -52.29 |
| 22 Point 22 | -1 -15 -29.66 | -62 -10 -32.27 |
| 23 Point 23 | -1 -14 -42.42 | -62 -7 -25.71 |
| 24 Point 24 | -1 -11 -37.50 | -62 -8 -56.56 |

Figure 101. Input Spreadsheet's Excel screenshot, considering a boat width of 1.64 feet.

| Fastest Path | | | | | | | | | | | | | | | | |
|--------------|------|--------|---------------|------------------------|------------------------|---|---|---|------------|--------|---------|---------------|------------------------|---|---|---|
| A | B | C | D | E | F | G | H | I | J | K | L | M | N | O | P | Q |
| Fastest Path | Risk | Time | Survivability | Weighted Survivability | | | | | Start Time | Risk | Time | Survivability | Weighted Survivability | | | |
| 1 | | | | | | | | | | | | | | | | |
| 2 | 38 | 0.0000 | 1.8017 | 1.0000 | | | | | 8:00 | 0.0000 | 10.5259 | 1.0000 | 1.0000 | | | |
| 3 | 32 | 0.0000 | 1.1358 | 1.0000 | | | | | 8:30 | 0.0000 | 10.5259 | 1.0000 | 1.0000 | | | |
| 4 | 23 | 0.0000 | 3.0245 | 1.0000 | | | | | 9:00 | 0.0000 | 10.5259 | 1.0000 | 1.0000 | | | |
| 5 | 18 | 0.0000 | 1.9066 | 1.0000 | | | | | 9:30 | 0.0000 | 10.5259 | 1.0000 | 1.0000 | | | |
| 6 | 10 | 0.0000 | 1.3999 | 1.0000 | | | | | 10:00 | 0.0000 | 10.5259 | 1.0000 | 1.0000 | | | |
| 7 | 5 | 0.0000 | 1.2574 | 1.0000 | | | | | 10:30 | 0.0000 | 10.5259 | 1.0000 | 1.0000 | | | |
| 8 | 1 | 0.0000 | 0.0000 | 1.0000 | | | | | 11:00 | 0.0000 | 10.5259 | 1.0000 | 1.0000 | | | |
| 9 | | | | | | | | | 11:30 | 0.0000 | 10.5259 | 1.0000 | 1.0000 | | | |
| 10 | | 0.0000 | 10.5259 | 1.0000 | | | | | 12:00 | 0.0000 | 10.5259 | 1.0000 | 1.0000 | | | |
| 11 | | | | | | | | | 12:30 | 0.5600 | 10.5774 | 0.4400 | 0.8991 | | | |
| 12 | Path | Risk | Time | Survivability | Weighted Survivability | | | | 13:00 | 0.8124 | 10.6335 | 0.3009 | 0.8859 | | | |
| 13 | 38 | 0.0000 | 1.8017 | 1.0000 | 1.8017 | | | | 13:30 | 0.2812 | 14.0617 | 0.7188 | 0.9756 | | | |
| 14 | 32 | 0.0000 | 1.1358 | 1.0000 | 1.1358 | | | | 14:00 | 0.0000 | 10.5259 | 1.0000 | 1.0000 | | | |
| 15 | 23 | 0.0000 | 3.0245 | 1.0000 | 3.0245 | | | | 14:30 | 0.0000 | 11.0599 | 1.0000 | 1.0000 | | | |
| 16 | 18 | 0.0000 | 1.9066 | 1.0000 | 1.9066 | | | | 15:00 | 0.0000 | 10.5259 | 1.0000 | 1.0000 | | | |
| 17 | 10 | 0.0000 | 1.3999 | 1.0000 | 1.3999 | | | | 15:30 | 0.0000 | 10.5259 | 1.0000 | 1.0000 | | | |
| 18 | 5 | 0.0000 | 1.2574 | 1.0000 | 1.2574 | | | | 16:00 | 0.0000 | 10.5259 | 1.0000 | 1.0000 | | | |
| 19 | 1 | 0.0000 | 0.0000 | 1.0000 | 0.0000 | | | | 16:30 | 0.0000 | 10.5259 | 1.0000 | 1.0000 | | | |
| 20 | | | | | | | | | 17:00 | 0.0000 | 10.5259 | 1.0000 | 1.0000 | | | |
| 21 | | 0.0000 | 10.5259 | 1.0000 | 1.0000 | | | | 17:30 | 0.0000 | 10.5259 | 1.0000 | 1.0000 | | | |
| 22 | | | | | | | | | 18:00 | 0.0000 | 10.5259 | 1.0000 | 1.0000 | | | |
| 23 | Path | Risk | Time | Survivability | Weighted Survivability | | | | | | | | | | | |
| 24 | 38 | 0.0000 | 1.8017 | 1.0000 | 1.8017 | | | | | | | | | | | |
| 25 | 32 | 0.0000 | 1.1358 | 1.0000 | 1.1358 | | | | | | | | | | | |
| 26 | 23 | 0.0000 | 3.0245 | 1.0000 | 3.0245 | | | | | | | | | | | |
| 27 | 18 | 0.0000 | 1.9066 | 1.0000 | 1.9066 | | | | | | | | | | | |
| 28 | 10 | 0.0000 | 1.3999 | 1.0000 | 1.3999 | | | | | | | | | | | |
| 29 | 5 | 0.0000 | 1.2574 | 1.0000 | 1.2574 | | | | | | | | | | | |
| 30 | 1 | 0.0000 | 0.0000 | 1.0000 | 0.0000 | | | | | | | | | | | |
| 31 | | | | | | | | | | | | | | | | |
| 32 | | 0.0000 | 10.5259 | 1.0000 | 1.0000 | | | | | | | | | | | |
| 33 | | | | | | | | | | | | | | | | |

Figure 102. Output Spreadsheet's Excel screenshot, considering a boat width of 1.64 feet.

| Fastest Path | | | | | | | | | | | | | | | | |
|--------------|------|--------|---------------|------------------------|------------------------|---|---|---|------------|--------|---------|---------------|------------------------|---|---|---|
| A | B | C | D | E | F | G | H | I | J | K | L | M | N | O | P | Q |
| Fastest Path | Risk | Time | Survivability | Weighted Survivability | | | | | Start Time | Risk | Time | Survivability | Weighted Survivability | | | |
| 1 | | | | | | | | | | | | | | | | |
| 2 | 38 | 0.0000 | 1.8017 | 1.0000 | | | | | 8:00 | 0.0000 | 10.5259 | 1.0000 | 1.0000 | | | |
| 3 | 32 | 0.0000 | 1.1358 | 1.0000 | | | | | 8:30 | 0.0000 | 10.8079 | 1.0000 | 1.0000 | | | |
| 4 | 23 | 0.0000 | 3.0245 | 1.0000 | | | | | 9:00 | 0.0000 | 10.5259 | 1.0000 | 1.0000 | | | |
| 5 | 18 | 0.0000 | 1.9066 | 1.0000 | | | | | 9:30 | 0.0000 | 10.5259 | 1.0000 | 1.0000 | | | |
| 6 | 10 | 0.0000 | 1.3999 | 1.0000 | | | | | 10:00 | 0.0000 | 10.5259 | 1.0000 | 1.0000 | | | |
| 7 | 5 | 0.0000 | 1.2574 | 1.0000 | | | | | 10:30 | 0.0000 | 10.5259 | 1.0000 | 1.0000 | | | |
| 8 | 1 | 0.0000 | 0.0000 | 1.0000 | | | | | 11:00 | 0.0000 | 10.5259 | 1.0000 | 1.0000 | | | |
| 9 | | | | | | | | | 11:30 | 0.0000 | 10.5259 | 1.0000 | 1.0000 | | | |
| 10 | | 0.0000 | 10.5259 | 1.0000 | | | | | 12:00 | 0.8559 | 10.5774 | 0.3441 | 0.8818 | | | |
| 11 | | | | | | | | | 12:30 | 0.5397 | 12.2820 | 0.5497 | 0.9367 | | | |
| 12 | Path | Risk | Time | Survivability | Weighted Survivability | | | | 13:00 | 0.4062 | 10.6335 | 0.6224 | 0.9430 | | | |
| 13 | 38 | 0.0000 | 1.8017 | 1.0000 | 1.8017 | | | | 13:30 | 1.1366 | 13.7455 | 0.2125 | 0.8279 | | | |
| 14 | 32 | 0.0000 | 1.1358 | 1.0000 | 1.1358 | | | | 14:00 | 0.0810 | 13.6764 | 0.9190 | 0.9921 | | | |
| 15 | 23 | 0.0000 | 3.0245 | 1.0000 | 3.0245 | | | | 14:30 | 0.0000 | 10.5259 | 1.0000 | 1.0000 | | | |
| 16 | 18 | 0.0000 | 1.9066 | 1.0000 | 1.9066 | | | | 15:00 | 0.0000 | 10.5259 | 1.0000 | 1.0000 | | | |
| 17 | 10 | 0.0000 | 1.3999 | 1.0000 | 1.3999 | | | | 15:30 | 0.0000 | 14.0617 | 1.0000 | 1.0000 | | | |
| 18 | 5 | 0.0000 | 1.2574 | 1.0000 | 1.2574 | | | | 16:00 | 0.0000 | 10.5259 | 1.0000 | 1.0000 | | | |
| 19 | 1 | 0.0000 | 0.0000 | 1.0000 | 0.0000 | | | | 16:30 | 0.0000 | 10.5259 | 1.0000 | 1.0000 | | | |
| 20 | | | | | | | | | 17:00 | 0.0000 | 10.5259 | 1.0000 | 1.0000 | | | |
| 21 | | 0.0000 | 10.5259 | 1.0000 | 1.0000 | | | | 17:30 | 0.0000 | 10.5259 | 1.0000 | 1.0000 | | | |
| 22 | | | | | | | | | 18:00 | 0.0000 | 10.5259 | 1.0000 | 1.0000 | | | |
| 23 | Path | Risk | Time | Survivability | Weighted Survivability | | | | | | | | | | | |
| 24 | 38 | 0.0000 | 0.4593 | 1.0000 | 0.4593 | | | | | | | | | | | |
| 25 | 37 | 0.0000 | 0.8324 | 1.0000 | 0.8324 | | | | | | | | | | | |
| 26 | 33 | 0.0000 | 0.7919 | 1.0000 | 0.7919 | | | | | | | | | | | |
| 27 | 32 | 0.0000 | 1.1358 | 1.0000 | 1.1358 | | | | | | | | | | | |
| 28 | 23 | 0.0000 | 3.0245 | 1.0000 | 3.0245 | | | | | | | | | | | |
| 29 | 18 | 0.0000 | 1.9066 | 1.0000 | 1.9066 | | | | | | | | | | | |
| 30 | 10 | 0.0000 | 1.3999 | 1.0000 | 1.3999 | | | | | | | | | | | |
| 31 | 5 | 0.0000 | 1.2574 | 1.0000 | 1.2574 | | | | | | | | | | | |
| 32 | 1 | 0.0000 | 0.0000 | 1.0000 | 0.0000 | | | | | | | | | | | |
| 33 | | | | | | | | | | | | | | | | |

Figure 103. Output Spreadsheet's Excel screenshot, considering a boat width of 3.28 feet.

| Path | Risk | Time | Survivability | Weighted Survivability |
|---------|--------|---------|---------------|------------------------|
| 38 | 0.0000 | 1.8017 | 1.0000 | 1.8017 |
| 32 | 0.0000 | 1.1358 | 1.0000 | 1.1358 |
| 23 | 0.0000 | 3.0245 | 1.0000 | 3.0245 |
| 18 | 0.0000 | 1.9066 | 1.0000 | 1.9066 |
| 10 | 0.0000 | 1.3999 | 1.0000 | 1.3999 |
| 5 | 0.0000 | 1.2574 | 1.0000 | 1.2574 |
| 1 | 0.0000 | 0.0000 | 1.0000 | 0.0000 |
| 10.5259 | 0.0000 | 10.5259 | 1.0000 | 1.0000 |
| 8:00 | Risk | Time | Survivability | Weighted Survivability |
| 38 | 0.0000 | 1.8017 | 1.0000 | 1.8017 |
| 32 | 0.0000 | 1.1358 | 1.0000 | 1.1358 |
| 23 | 0.0000 | 3.0245 | 1.0000 | 3.0245 |
| 18 | 0.0000 | 1.9066 | 1.0000 | 1.9066 |
| 10 | 0.0000 | 1.3999 | 1.0000 | 1.3999 |
| 5 | 0.0000 | 1.2574 | 1.0000 | 1.2574 |
| 1 | 0.0000 | 0.0000 | 1.0000 | 0.0000 |
| 10.5259 | 0.0000 | 10.5259 | 1.0000 | 1.0000 |
| 8:30 | Risk | Time | Survivability | Weighted Survivability |
| 38 | 0.0000 | 0.4593 | 1.0000 | 0.4593 |
| 37 | 0.0000 | 0.8324 | 1.0000 | 0.8324 |
| 33 | 0.0000 | 0.7919 | 1.0000 | 0.7919 |
| 32 | 0.0000 | 1.1358 | 1.0000 | 1.1358 |
| 23 | 0.0000 | 3.0245 | 1.0000 | 3.0245 |
| 18 | 0.0000 | 1.9066 | 1.0000 | 1.9066 |
| 10 | 0.0000 | 1.3999 | 1.0000 | 1.3999 |
| 5 | 0.0000 | 1.2574 | 1.0000 | 1.2574 |
| 1 | 0.0000 | 0.0000 | 1.0000 | 0.0000 |

Figure 104. Output Spreadsheet's Excel screenshot, considering a boat width of 4.92 feet.

| Path | Risk | Time | Survivability | Weighted Survivability |
|---------|---------|---------|---------------|------------------------|
| 38 | 0.7729 | 1.8017 | 0.2271 | 0.4091 |
| 32 | 0.0000 | 1.1358 | 1.0000 | 1.1358 |
| 23 | 0.0000 | 3.0245 | 1.0000 | 3.0245 |
| 18 | 0.0000 | 1.9066 | 1.0000 | 1.9066 |
| 10 | 0.0000 | 1.3999 | 1.0000 | 1.3999 |
| 5 | 0.0000 | 1.2574 | 1.0000 | 1.2574 |
| 1 | 0.0000 | 0.0000 | 1.0000 | 0.0000 |
| 0.7729 | 10.5259 | 0.2271 | 0.8677 | |
| 8:00 | Risk | Time | Survivability | Weighted Survivability |
| 38 | 0.0000 | 0.4593 | 1.0000 | 0.4593 |
| 37 | 0.0000 | 0.8324 | 1.0000 | 0.8324 |
| 33 | 0.0000 | 0.7919 | 1.0000 | 0.7919 |
| 32 | 0.0000 | 1.1358 | 1.0000 | 1.1358 |
| 23 | 0.0000 | 3.0245 | 1.0000 | 3.0245 |
| 18 | 0.0000 | 1.9066 | 1.0000 | 1.9066 |
| 10 | 0.0000 | 1.3999 | 1.0000 | 1.3999 |
| 5 | 0.0000 | 1.2574 | 1.0000 | 1.2574 |
| 1 | 0.0000 | 0.0000 | 1.0000 | 0.0000 |
| 10.8079 | 0.0000 | 10.8079 | 1.0000 | 1.0000 |
| 8:30 | Risk | Time | Survivability | Weighted Survivability |
| 38 | 0.0000 | 0.4593 | 1.0000 | 0.4593 |
| 37 | 0.0000 | 0.8324 | 1.0000 | 0.8324 |
| 33 | 0.0000 | 0.7919 | 1.0000 | 0.7919 |
| 32 | 0.0000 | 1.1358 | 1.0000 | 1.1358 |
| 23 | 0.0000 | 3.0245 | 1.0000 | 3.0245 |
| 18 | 0.0000 | 1.9066 | 1.0000 | 1.9066 |
| 10 | 0.0000 | 1.3999 | 1.0000 | 1.3999 |
| 5 | 0.0000 | 1.2574 | 1.0000 | 1.2574 |

Figure 105. Output Spreadsheet's Excel screenshot, considering a boat width of 6.56 feet.

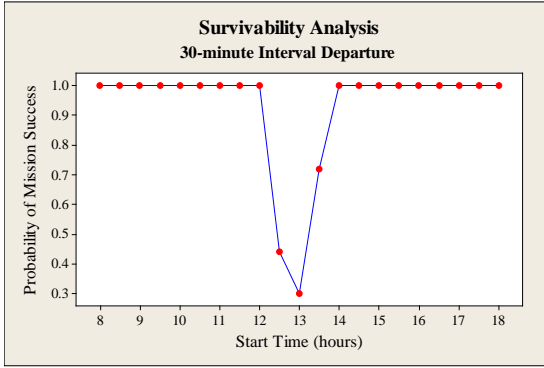

Figure 106. Graphic presenting the boat capability of surviving the supply mission, given 1.64 feet of width, with 30-minute interval departure.

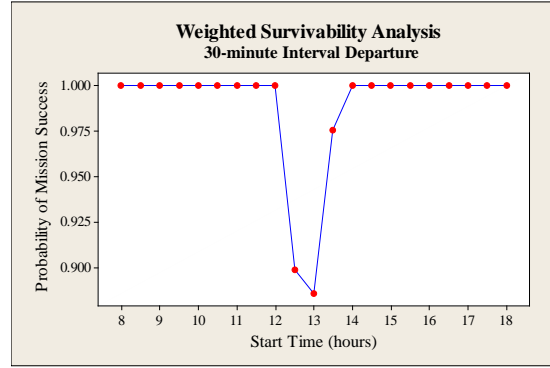

Figure 107. Graphic presenting the boat capability of surviving the supply mission, given 1.64 feet of width, emphasizing the importance of travel time, with 30-minute interval departure.

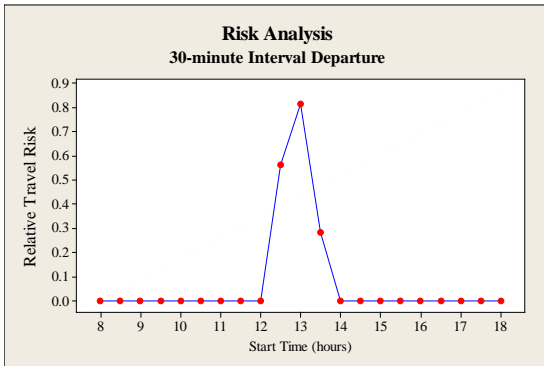

Figure 108. Graphic presenting the relative travel risk throughout the complete route, given 1.64 feet of width, with 30-minute interval departure.

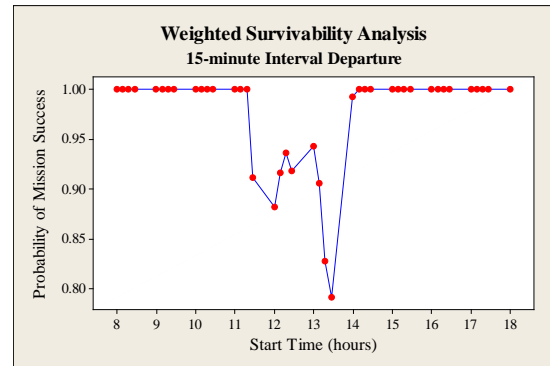

Figure 109. Graphic presenting the boat capability of surviving the supply mission, given 1.64 feet of width, emphasizing the importance of travel time, with 15-minute interval departure.

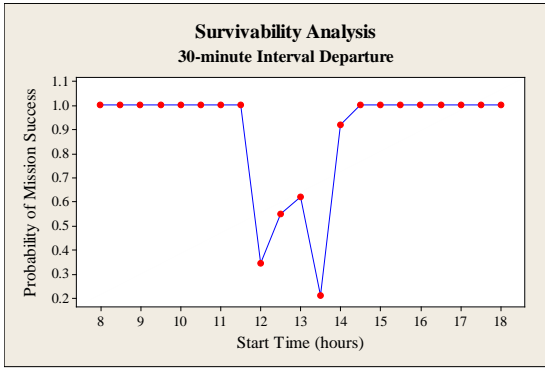

Figure 110. Graphic presenting the boat capability of surviving the supply mission, given 3.28 feet of width, with 30-minute interval departure.

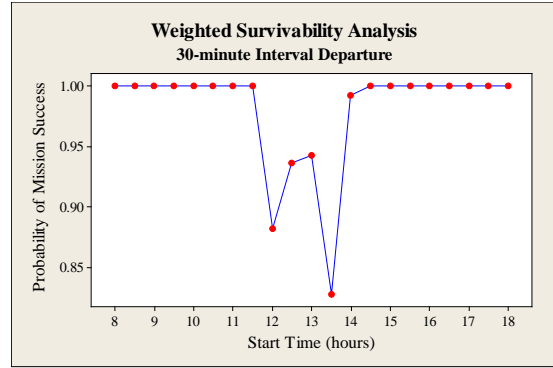

Figure 111. Graphic presenting the boat capability of surviving the supply mission, given 3.28 feet of width, emphasizing the importance of travel time, with 30-minute interval departure.

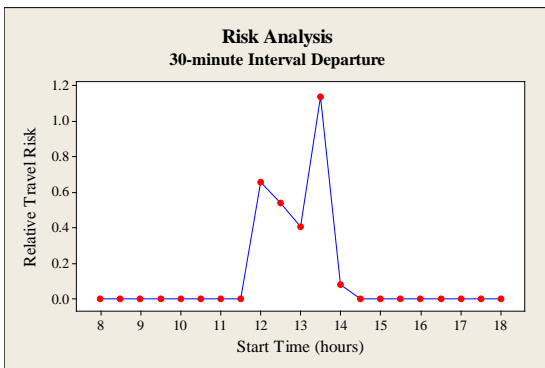

Figure 112. Graphic presenting the relative travel risk throughout the complete route, given 3.28 feet of width, with 30-minute interval departure.

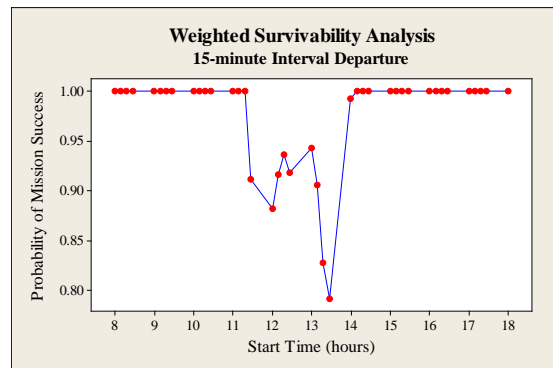

Figure 113. Graphic presenting the boat capability of surviving the supply mission, given 3.28 feet of width, emphasizing the importance of travel time, with 15-minute interval departure.

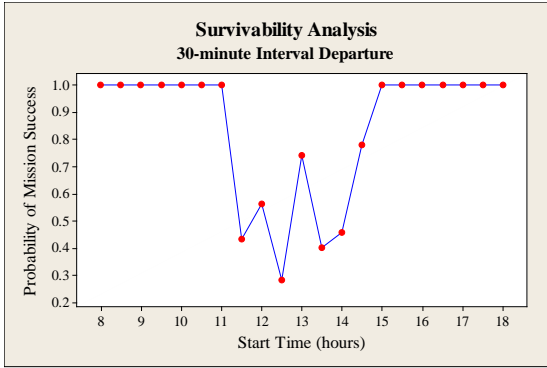

Figure 114. Graphic presenting the boat capability of surviving the supply mission, given 4.92 feet of width, with 30-minute interval departure.

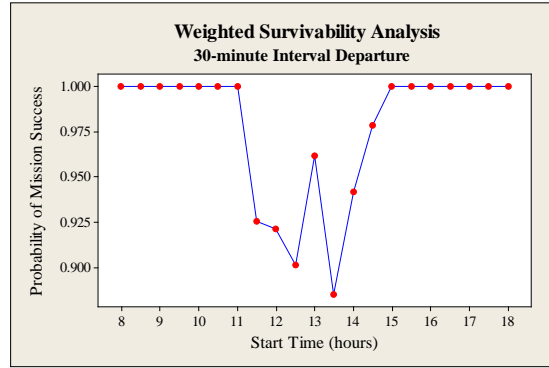

Figure 115. Graphic presenting the boat capability of surviving the supply mission, given 4.92 feet of width, emphasizing the importance of travel time, with 30-minute interval departure.

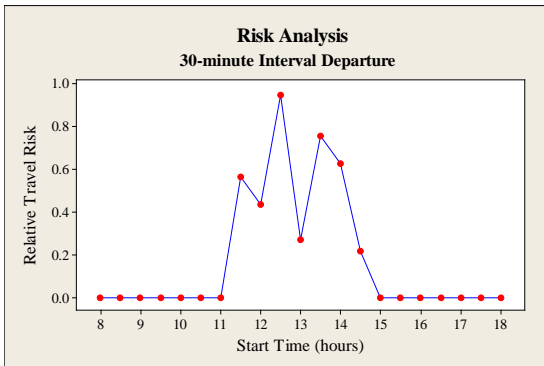

Figure 116. Graphic presenting the relative travel risk throughout the complete route, given 4.92 feet of width, with 30-minute interval departure.

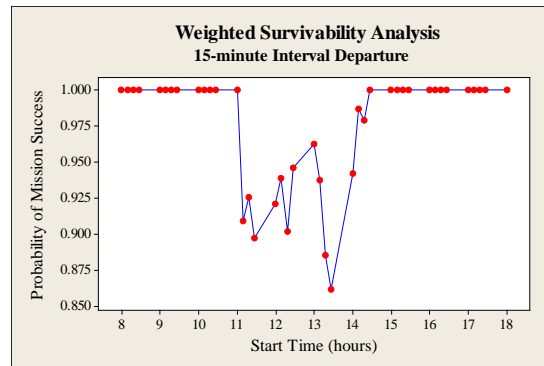

Figure 117. Graphic presenting the boat capability of surviving the supply mission, given 4.92 feet of width, emphasizing the importance of travel time, with 15-minute interval departure.

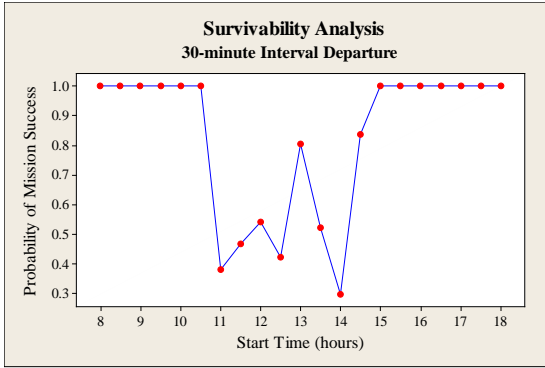

Figure 118. Graphic presenting the boat capability of surviving the supply mission, given 6.56 feet of width, with 30-minute interval departure.

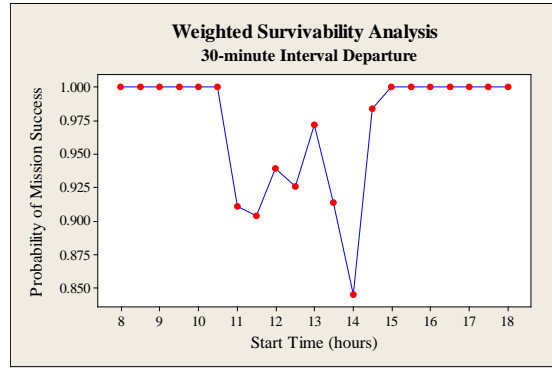

Figure 119. Graphic presenting the boat capability of surviving the supply mission, given 6.56 feet of width, emphasizing the importance of travel time, with 30-minute interval departure.

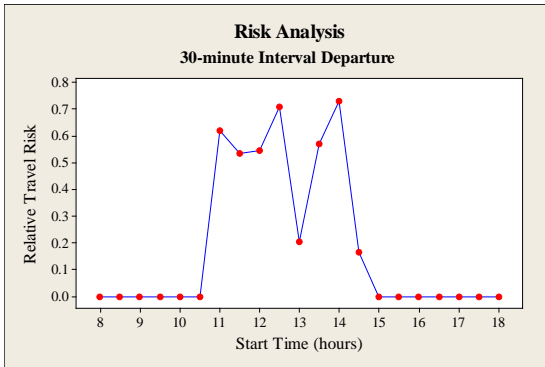

Figure 120. Graphic presenting the relative travel risk throughout the complete route, given 6.56 feet of width, with 30-minute interval departure.

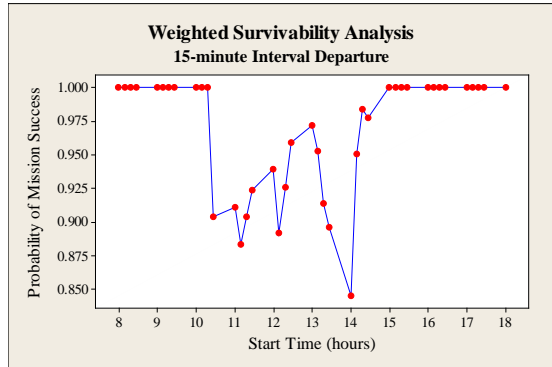

Figure 121. Graphic presenting the boat capability of surviving the supply mission, given 6.56 feet of width, emphasizing the importance of travel time, with 15-minute interval departure.

In this study the magnitude of the influence of the variable “boat width” on stealthy boat ability became evident. Therefore, the more dimensional analysis, conducted against risk/survivability assessment can help military planners designing stealthier watercraft models that could be employed in dense tropical forest streams in order to avoid or reduce aerial detection by enemy searchers. Also, analyzing the Excel output screenshot, it is possible to verify that faster travel, starting at earliest travel time, rarely produces optimal stealthy routes, except for the extreme conditions of either excessively high trees or powerful boat engines.

Predictive Validation

This tool is a dynamic verification procedure used to compare specific outcomes in the real world to corresponding outcomes in the model. It’s considered “a primary method for providing evidence that a simulation is an accurate representation of an actual system” (Ledin, 2001:217). Given some data, the model is executed with the same inputs and its results are compared with the historical or experimental data.

In this experiment, the model was ran, under ordinary conditions (figure 91), in order to assesses its result. After that, parameters directly related to the provided outcome will be replaced in order to verify how the model reacts to the new condition.

Once the model ran, the best routes chosen, i.e. these that provide null risk, were the following (figure 92):

- a) 1-5-10-18-23-32-33-37-38: starting between 8:00h and 8:45h;
- b) 1-5-10-12-20-25-34-36-48-51-57-59-55-47-39-29-38: starting between 9:00h and 9:15h;
- c) 1-5-10-12-20-25-34-36-48-48-51-49-43-38: starting between 9:30h and 10:30h;

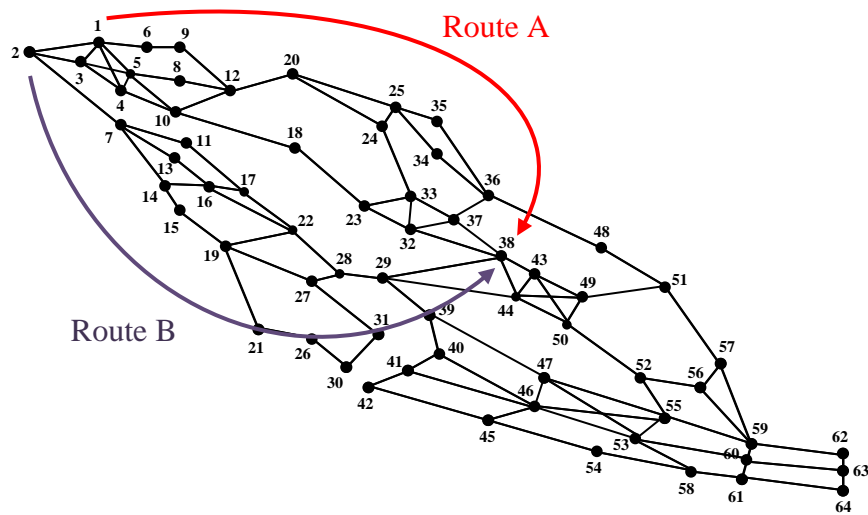

Figure 123. Theoretical network plot showing the two different scenarios.

| Fastest Path | | | | | | Start | | | | |
|--------------|--------|--------|---------------|------------------------|--|------------|--------|---------|---------------|------------------------|
| Fastest Path | Risk | Time | Survivability | Weighted Survivability | | Start Time | Risk | Time | Survivability | Weighted Survivability |
| 38 | 0.7729 | 1.0810 | 0.2271 | 0.2455 | | 8:00 | 0.0000 | 6.4848 | 1.0000 | 1.0000 |
| 32 | 0.0000 | 0.6815 | 1.0000 | 0.6815 | | 8:15 | 0.0000 | 6.4848 | 1.0000 | 1.0000 |
| 23 | 0.0000 | 1.8147 | 1.0000 | 1.8147 | | 8:30 | 0.0000 | 6.4848 | 1.0000 | 1.0000 |
| 18 | 0.0000 | 1.1440 | 1.0000 | 1.1440 | | 8:45 | 0.0000 | 6.4848 | 1.0000 | 1.0000 |
| 10 | 0.0000 | 0.8400 | 1.0000 | 0.8400 | | 9:00 | 0.0000 | 18.2180 | 1.0000 | 1.0000 |
| 5 | 0.0000 | 0.7545 | 1.0000 | 0.7545 | | 9:15 | 0.0000 | 18.2180 | 1.0000 | 1.0000 |
| 1 | 0.0000 | 0.0000 | 1.0000 | 0.0000 | | 9:30 | 0.0000 | 12.4384 | 1.0000 | 1.0000 |
| | 0.7729 | 6.3156 | 0.2271 | 0.8677 | | 9:45 | 0.0000 | 12.4384 | 1.0000 | 1.0000 |
| | | | | | | 10:00 | 0.0000 | 12.4384 | 1.0000 | 1.0000 |
| | | | | | | 10:15 | 0.0000 | 12.6076 | 1.0000 | 1.0000 |
| | | | | | | 10:30 | 0.0000 | 12.6076 | 1.0000 | 1.0000 |
| | | | | | | 10:45 | 0.7278 | 18.2180 | 0.2722 | 0.9609 |
| | | | | | | 11:00 | 0.8178 | 12.6868 | 0.3822 | 0.9523 |
| | | | | | | 11:15 | 0.7834 | 12.4693 | 0.3127 | 0.9312 |
| | | | | | | 11:30 | 0.6539 | 12.4693 | 0.4105 | 0.9412 |
| | | | | | | 11:45 | 1.0213 | 8.4875 | 0.0000 | 0.9031 |
| | | | | | | 12:00 | 0.9626 | 12.3785 | 0.3163 | 0.9150 |
| | | | | | | 12:15 | 2.2302 | 8.2491 | 0.0388 | 0.7703 |
| | | | | | | 12:30 | 1.8767 | 6.3492 | 0.0799 | 0.6748 |
| | | | | | | 12:45 | 1.1041 | 6.3492 | 0.2754 | 0.8073 |
| | | | | | | 13:00 | 0.2937 | 6.3492 | 0.7313 | 0.8455 |
| | | | | | | 13:15 | 0.5505 | 6.3492 | 0.5574 | 0.9091 |
| | | | | | | 13:30 | 1.1259 | 6.7551 | 0.2743 | 0.8437 |
| | | | | | | 13:45 | 1.6169 | 12.6173 | 0.1146 | 0.8611 |
| | | | | | | 14:00 | 2.0493 | 7.2673 | 0.0625 | 0.7418 |
| | | | | | | 14:15 | 1.1415 | 8.4241 | 0.0806 | 0.7878 |
| | | | | | | 14:30 | 0.1645 | 8.2059 | 0.8355 | 0.9839 |
| | | | | | | 14:45 | 0.2301 | 8.4375 | 0.7699 | 0.9792 |
| | | | | | | 15:00 | 0.2991 | 8.4875 | 0.7009 | 0.9717 |
| | | | | | | 15:15 | 0.3726 | 8.4875 | 0.6274 | 0.9647 |
| | | | | | | 15:30 | 0.0000 | 6.3156 | 1.0000 | 1.0000 |
| | | | | | | 15:45 | 0.0000 | 6.3156 | 1.0000 | 1.0000 |
| | | | | | | 16:00 | 0.0000 | 6.3156 | 1.0000 | 1.0000 |
| | | | | | | 16:15 | 0.0000 | 6.3156 | 1.0000 | 1.0000 |
| | | | | | | 16:30 | 0.0000 | 6.3156 | 1.0000 | 1.0000 |
| | | | | | | 16:45 | 0.0000 | 6.8150 | 1.0000 | 1.0000 |
| | | | | | | 17:00 | 0.0000 | 8.2059 | 1.0000 | 1.0000 |
| | | | | | | 17:15 | 0.0000 | 6.3156 | 1.0000 | 1.0000 |
| | | | | | | 17:30 | 0.0000 | 6.3156 | 1.0000 | 1.0000 |
| | | | | | | 17:45 | 0.0000 | 6.3156 | 1.0000 | 1.0000 |
| | | | | | | 18:00 | 0.0000 | 6.3156 | 1.0000 | 1.0000 |

Figure 124. Output Spreadsheet's Excel screenshot, considering a normal operational scenario.

| A1 | | fx | | | | | | | | | | | | | | | | | | | | | |
|----|-------------|---------------------|----------|---------------------|-----|----------------------|------------|-----------|--------|-------|---|---|---|---|---|---|---|---|---|---|---|---|--|
| A | B | C | D | E | F | G | H | I | J | K | L | M | N | O | P | Q | R | S | T | U | V | W | |
| 1 | | | | time-zone | -3 | aylight Saving | 0 | Sunrise | 7.218 | hours | | | | | | | | | | | | | |
| 2 | | Day | 21 | Hour | 8 | | | Solarnoon | 13.272 | hours | | | | | | | | | | | | | |
| 3 | | Month | 3 | Minute | 0 | Earliest Start | 8 | Sunset | 19.326 | hours | | | | | | | | | | | | | |
| 4 | | Year | 2010 | Second | 0 | Latest Start | 18 | | | | | | | | | | | | | | | | |
| 5 | | Leap Year | 0 | | | | | | | | | | | | | | | | | | | | |
| 6 | | Boat with= | 0.001242 | miles | 2 | meters | 6.56167979 | feet | | | | | | | | | | | | | | | |
| 7 | | Boat speed= | 3.106059 | miles/hour | 5 | Kmh | | | | | | | | | | | | | | | | | |
| 8 | | Ratio of the Earth= | 3,963.17 | miles | | | | | | | | | | | | | | | | | | | |
| 9 | | | | | | | | | | | | | | | | | | | | | | | |
| 10 | | | | | | | | | | | | | | | | | | | | | | | |
| 11 | | | | geographic latitude | | geographic longitude | | | | | | | | | | | | | | | | | |
| 12 | Nodes | D | M | S | D | M | S | | | | | | | | | | | | | | | | |
| 13 | 1 Point 01 | -1 | -8 | -33.39 | -62 | -18 | -2.93 | | | | | | | | | | | | | | | | |
| 14 | 2 Point 02 | -1 | -8 | -56.77 | -62 | -20 | -10.73 | | | | | | | | | | | | | | | | |
| 15 | 3 Point 03 | -1 | -9 | -20.87 | -62 | -18 | -14.87 | | | | | | | | | | | | | | | | |
| 16 | 4 Point 04 | -1 | -10 | -10.27 | -62 | -16 | -27.98 | | | | | | | | | | | | | | | | |
| 17 | 5 Point 05 | -1 | -9 | -38.05 | -62 | -16 | -19.46 | | | | | | | | | | | | | | | | |
| 18 | 6 Point 06 | -1 | -8 | -30.17 | -62 | -15 | -30.58 | | | | | | | | | | | | | | | | |
| 19 | 7 Point 07 | -1 | -11 | -59.28 | -62 | -16 | -18.18 | | | | | | | | | | | | | | | | |
| 20 | 8 Point 08 | -1 | -9 | -50.01 | -62 | -14 | -17.58 | | | | | | | | | | | | | | | | |
| 21 | 9 Point 09 | -1 | -8 | -47.25 | -62 | -14 | -2.39 | | | | | | | | | | | | | | | | |
| 22 | 10 Point 10 | -1 | -10 | -57.86 | -62 | -14 | -29.54 | | | | | | | | | | | | | | | | |
| 23 | 11 Point 11 | -1 | -12 | -12.48 | -62 | -14 | -38.15 | | | | | | | | | | | | | | | | |
| 24 | 12 Point 12 | -1 | -10 | -17.27 | -62 | -12 | -42.80 | | | | | | | | | | | | | | | | |
| 25 | 13 Point 13 | -1 | -12 | -48.08 | -62 | -14 | -53.47 | | | | | | | | | | | | | | | | |
| 26 | 14 Point 14 | -1 | -13 | -35.56 | -62 | -15 | -2.00 | | | | | | | | | | | | | | | | |
| 27 | 15 Point 15 | -1 | -14 | -19.68 | -62 | -14 | -45.10 | | | | | | | | | | | | | | | | |
| 28 | 16 Point 16 | -1 | -14 | -19.83 | -62 | -12 | -53.10 | | | | | | | | | | | | | | | | |
| 29 | 17 Point 17 | -1 | -13 | -57.84 | -62 | -12 | -19.15 | | | | | | | | | | | | | | | | |
| 30 | 18 Point 18 | -1 | -11 | -47.40 | -62 | -11 | -31.28 | | | | | | | | | | | | | | | | |
| 31 | 19 Point 19 | -1 | -15 | -58.30 | -62 | -12 | -58.26 | | | | | | | | | | | | | | | | |
| 32 | 20 Point 20 | -1 | -9 | -41.88 | -62 | -10 | -8.37 | | | | | | | | | | | | | | | | |
| 33 | 21 Point 21 | -1 | -18 | -9.03 | -62 | -11 | -52.29 | | | | | | | | | | | | | | | | |
| 34 | 22 Point 22 | -1 | -15 | -29.66 | -62 | -10 | -32.27 | | | | | | | | | | | | | | | | |
| 35 | 23 Point 23 | -1 | -14 | -42.42 | -62 | -7 | -35.71 | | | | | | | | | | | | | | | | |
| 36 | 24 Point 24 | -1 | -11 | -37.50 | -62 | -6 | -56.56 | | | | | | | | | | | | | | | | |

| ij | 1 | 2 | 3 | 4 | 5 | 6 | 7 | 8 | 9 | 10 | 11 |
|----|--------|--------|--------|--------|--------|--------|--------|--------|--------|--------|--------|
| 1 | 0.0000 | 0.0062 | 0.0062 | 0.0000 | 0.0000 | 0.0000 | 0.0000 | 0.0000 | 0.0000 | 0.0000 | 0.0000 |
| 2 | 0.0062 | 0.0062 | 0.0062 | 0.0062 | 0.0062 | 0.0062 | 0.0062 | 0.0062 | 0.0062 | 0.0062 | 0.0062 |
| 3 | 0.0000 | 0.0000 | 0.0000 | 0.0000 | 0.0000 | 0.0000 | 0.0000 | 0.0000 | 0.0000 | 0.0000 | 0.0000 |
| 4 | 0.0000 | 0.0000 | 0.0000 | 0.0000 | 0.0000 | 0.0000 | 0.0000 | 0.0000 | 0.0000 | 0.0000 | 0.0000 |
| 5 | 0.0000 | 0.0000 | 0.0000 | 0.0000 | 0.0000 | 0.0000 | 0.0000 | 0.0000 | 0.0000 | 0.0000 | 0.0000 |
| 6 | 0.0000 | 0.0000 | 0.0000 | 0.0000 | 0.0000 | 0.0000 | 0.0000 | 0.0000 | 0.0000 | 0.0000 | 0.0000 |
| 7 | 0.0062 | 0.0062 | 0.0062 | 0.0062 | 0.0062 | 0.0062 | 0.0062 | 0.0062 | 0.0062 | 0.0062 | 0.0062 |
| 8 | 0.0000 | 0.0000 | 0.0000 | 0.0000 | 0.0000 | 0.0000 | 0.0000 | 0.0000 | 0.0000 | 0.0000 | 0.0000 |
| 9 | 0.0000 | 0.0000 | 0.0000 | 0.0000 | 0.0000 | 0.0000 | 0.0000 | 0.0000 | 0.0000 | 0.0000 | 0.0000 |
| 10 | 0.0000 | 0.0000 | 0.0000 | 0.0000 | 0.0000 | 0.0000 | 0.0000 | 0.0000 | 0.0000 | 0.0000 | 0.0000 |
| 11 | 0.0062 | 0.0062 | 0.0062 | 0.0062 | 0.0062 | 0.0062 | 0.0062 | 0.0062 | 0.0062 | 0.0062 | 0.0062 |
| 12 | 0.0000 | 0.0000 | 0.0000 | 0.0000 | 0.0000 | 0.0000 | 0.0000 | 0.0000 | 0.0000 | 0.0000 | 0.0000 |
| 13 | 0.0062 | 0.0062 | 0.0062 | 0.0062 | 0.0062 | 0.0062 | 0.0062 | 0.0062 | 0.0062 | 0.0062 | 0.0062 |
| 14 | 0.0062 | 0.0062 | 0.0062 | 0.0062 | 0.0062 | 0.0062 | 0.0062 | 0.0062 | 0.0062 | 0.0062 | 0.0062 |
| 15 | 0.0062 | 0.0062 | 0.0062 | 0.0062 | 0.0062 | 0.0062 | 0.0062 | 0.0062 | 0.0062 | 0.0062 | 0.0062 |
| 16 | 0.0062 | 0.0062 | 0.0062 | 0.0062 | 0.0062 | 0.0062 | 0.0062 | 0.0062 | 0.0062 | 0.0062 | 0.0062 |
| 17 | 0.0062 | 0.0062 | 0.0062 | 0.0062 | 0.0062 | 0.0062 | 0.0062 | 0.0062 | 0.0062 | 0.0062 | 0.0062 |
| 18 | 0.0000 | 0.0000 | 0.0000 | 0.0000 | 0.0000 | 0.0000 | 0.0000 | 0.0000 | 0.0000 | 0.0000 | 0.0000 |
| 19 | 0.0062 | 0.0062 | 0.0062 | 0.0062 | 0.0062 | 0.0062 | 0.0062 | 0.0062 | 0.0062 | 0.0062 | 0.0062 |
| 20 | 0.0000 | 0.0000 | 0.0000 | 0.0000 | 0.0000 | 0.0000 | 0.0000 | 0.0000 | 0.0000 | 0.0000 | 0.0000 |
| 21 | 0.0062 | 0.0062 | 0.0062 | 0.0062 | 0.0062 | 0.0062 | 0.0062 | 0.0062 | 0.0062 | 0.0062 | 0.0062 |
| 22 | 0.0062 | 0.0062 | 0.0062 | 0.0062 | 0.0062 | 0.0062 | 0.0062 | 0.0062 | 0.0062 | 0.0062 | 0.0062 |
| 23 | 0.0000 | 0.0000 | 0.0000 | 0.0000 | 0.0000 | 0.0000 | 0.0000 | 0.0000 | 0.0000 | 0.0000 | 0.0000 |
| 24 | 0.0000 | 0.0000 | 0.0000 | 0.0000 | 0.0000 | 0.0000 | 0.0000 | 0.0000 | 0.0000 | 0.0000 | 0.0000 |

Figure 125. Input Spreadsheet's Excel screenshot, considering a new scenario configuration.

| A1 | | Fastest Path | | | | | | | | | | | | | | | | | |
|----|--------------|--------------|--------|---------------|------------------------|---|---|---|---|------------|--------|---------|---------------|------------------------|---|---|--|--|--|
| A | B | C | D | E | F | G | H | I | J | K | L | M | N | O | P | Q | | | |
| 1 | Fastest Path | Risk | Time | Survivability | Weighted Survivability | | | | | Start Time | Risk | Time | Survivability | Weighted Survivability | | | | | |
| 2 | 38 | 1.0000 | 1.0810 | 0.0000 | 0.0000 | | | | | 8:00 | 1.0000 | 8.2059 | 0.0000 | 0.9021 | | | | | |
| 3 | 32 | 1.0000 | 0.6815 | 0.0000 | 0.0000 | | | | | 8:15 | 1.9003 | 8.2059 | 0.0000 | 0.8032 | | | | | |
| 4 | 23 | 1.0000 | 1.8147 | 0.0000 | 0.0000 | | | | | 8:30 | 1.6839 | 8.2059 | 0.0000 | 0.8270 | | | | | |
| 5 | 18 | 1.0000 | 1.1440 | 0.0000 | 0.0000 | | | | | 8:45 | 1.5374 | 8.2059 | 0.0000 | 0.8431 | | | | | |
| 6 | 10 | 1.0000 | 0.8400 | 0.0000 | 0.0000 | | | | | 9:00 | 1.4307 | 8.2059 | 0.0000 | 0.8548 | | | | | |
| 7 | 5 | 1.0000 | 0.7454 | 0.0000 | 0.0000 | | | | | 9:15 | 1.3489 | 8.2059 | 0.0000 | 0.8638 | | | | | |
| 8 | 1 | 0.0000 | 0.0000 | 1.0000 | 0.0000 | | | | | 9:30 | 1.2837 | 8.2059 | 0.0000 | 0.8709 | | | | | |
| 9 | | | | | | | | | | 9:45 | 1.2299 | 8.2059 | 0.0000 | 0.8768 | | | | | |
| 10 | | 6.0000 | 6.3156 | 0.0000 | 0.0000 | | | | | 10:00 | 1.1845 | 8.2059 | 0.0000 | 0.8818 | | | | | |
| 11 | | | | | | | | | | 10:15 | 1.1452 | 8.2059 | 0.0000 | 0.8862 | | | | | |
| 12 | Path 8:00 | Risk | Time | Survivability | Weighted Survivability | | | | | 10:30 | 1.1106 | 8.2059 | 0.0000 | 0.8900 | | | | | |
| 13 | 38 | 0.0000 | 1.4196 | 1.0000 | 1.4196 | | | | | 10:45 | 1.0797 | 8.2059 | 0.0000 | 0.8934 | | | | | |
| 14 | 29 | 0.0000 | 0.9014 | 1.0000 | 0.9014 | | | | | 11:00 | 1.0515 | 8.2059 | 0.0000 | 0.8964 | | | | | |
| 15 | 28 | 0.0000 | 0.7454 | 1.0000 | 0.7454 | | | | | 11:15 | 1.0256 | 8.2059 | 0.0000 | 0.8993 | | | | | |
| 16 | 22 | 0.0000 | 0.9719 | 1.0000 | 0.9719 | | | | | 11:30 | 1.0015 | 8.4875 | 0.0000 | 0.9052 | | | | | |
| 17 | 16 | 0.0000 | 0.9359 | 1.0000 | 0.9359 | | | | | 11:45 | 1.0213 | 8.4875 | 0.0000 | 0.9031 | | | | | |
| 18 | 13 | 0.0000 | 0.6341 | 1.0000 | 0.6341 | | | | | 12:00 | 1.9217 | 11.4506 | 0.0000 | 0.7854 | | | | | |
| 19 | 7 | 0.0000 | 1.7941 | 1.0000 | 1.7941 | | | | | 12:15 | 2.5263 | 11.4506 | 0.0000 | 0.7547 | | | | | |
| 20 | 2 | 1.0000 | 0.8033 | 0.0000 | 0.0000 | | | | | 12:30 | 3.1713 | 8.2473 | 0.0000 | 0.6151 | | | | | |
| 21 | 1 | 0.0000 | 0.0000 | 1.0000 | 0.0000 | | | | | 12:45 | 2.2616 | 8.2473 | 0.0000 | 0.7335 | | | | | |
| 22 | | | | | | | | | | 13:00 | 1.4194 | 8.2059 | 0.0000 | 0.8490 | | | | | |
| 23 | | 1.0000 | 8.2059 | 0.0000 | 0.9021 | | | | | 13:15 | 1.2737 | 11.4506 | 0.0000 | 0.9030 | | | | | |
| 24 | | | | | | | | | | 13:30 | 1.1752 | 8.2473 | 0.2540 | 0.8423 | | | | | |
| 25 | Path 8:15 | Risk | Time | Survivability | Weighted Survivability | | | | | 13:45 | 1.6169 | 12.6173 | 0.1146 | 0.8611 | | | | | |
| 26 | 38 | 0.0000 | 1.4196 | 1.0000 | 1.4196 | | | | | 14:00 | 2.2332 | 12.6173 | 0.0259 | 0.8065 | | | | | |
| 27 | 29 | 0.9003 | 0.9014 | 0.9997 | 0.9099 | | | | | 14:15 | 1.1415 | 8.4241 | 0.0800 | 0.7878 | | | | | |
| 28 | 28 | 0.0000 | 0.7454 | 1.0000 | 0.7454 | | | | | 14:30 | 1.1645 | 8.2059 | 0.8355 | 0.9839 | | | | | |
| 29 | 22 | 0.0000 | 0.9719 | 1.0000 | 0.9719 | | | | | 14:45 | 0.2301 | 8.2 | | | | | | | |

Synthesis

The investigation performed on the computer program against the theoretical model proved conclusively its feasibility and performance in assessing move risk and survivability under stealthy movement in jungle environments.

The effects of path surroundings, such as riverine forest features, as well as inherent characteristics of boat, essentially its speed and width, influences stealth behavior movement. Both of them are travel start-time dependent. The solar noon move experiments greatly increase travel risk, since the sun is very far away from the earth. This is an essential element to be considered in the transverse planning process, as the main goal is to avoid enemy detection.

Another important consideration is referred to how many different risk assessment approaches are able to provide concise but significant insights to military planners about the safety routes and time-windows framework. At this time the military objective is the primary concern when choosing the risk evaluation method. Further, using properly the chosen tool is important. For example, selecting distinct time-range to start-time provides the user flexibility in identifying more convenient period to cross the network.

To sum up, the model reasonably achieved the purposed objective, providing a method to accurately calculate both routes and period of times that minimize detection probability taken into account the assumptions previously made.

V. Discussion

Introduction

This research provided a computational tool to calculate optimal routes and time window framework to supply a deployed jungle combat unit under restriction of an omnidirectional sensing searcher. This final chapter serves to sum up the entirety of this study as well as answer the research questions.

Insights

This research revealed valuable insights for future studies concerning combat logistics research topics, especially those concerned with travel risk assessment under enemy detection threat. The main insights are found in the following paragraphs.

First, it was evident the benefits of the concealment schemes employment for avoiding detection and movement tracking, in terms of position and speed taking. This technique, whose efficiency was historically proven, is an inherently military activity in which the major goal is to annul or reduce materiel and personnel loss due to enemy target acquisition. However, it also has been efficiently employed on civilian sectors, which have pursued performance improvements in artificial intelligence devices. Particularly in jungle warfare, because of the peculiar environmental conditions, hiding movements are relatively simple since movement is able to take advantage of shadows provided by botanical features. However, since this method conjugates both internal and external movement attributes such as boat dimension and forest features, respectively, optimal solutions arise from a balance between these two perspectives, which is quite difficult to achieve.

Second, changes in risk quantifier parameters don't affect proportionally and equally the boat vulnerability through the route. Increasing in boat speed, keeping its feasibility, for instance, demonstrates low impact in reducing boat vulnerability, since the distances between nodes are big and use of a powerful engine is impracticable because of disturbing stealthy behavior. On the other hand, a small variation on boat width produces large consequences for risk travel, being an important factor to be considered during the stealthy supply watercraft design process. Also, though riverine vegetation has a weighty influence on offering distinct shadow areas, there is no control over their facet, suggesting it has to be seen as a guideline to develop route strategies, travel machines models or depot location arrangements.

Third, the possibility of providing different analytic approaches to the same operational scenario contributes to a military planner, ability to attain simultaneously tactical and logistics objectives, since the outcomes are compatibly displayed with their goals. If a camp commander emphasizes the value of a zero-detection enemy travel, in transporting ammunitions, drugs or wounded soldiers, for example, the relative risk and survivability analysis are the best tools to be employed. However, if he has more freedom of action, both in space and time dimensions, to conduct his operations, as well as he pursues a better tactic-logistic integration, the weighted-survivability analysis is the outcome that can better help him during the trade-off process between available choices: faster delivery but more exposure of supplies, boats and its operator, or sacrificing the troops readiness against a guaranteed resupply.

Assumptions and Limitations

Some fundamental assumptions and limitations were presented in this study since its objective was to give quantitative visibility to solve a realistic, specific and well-defined military problem: supply combat units in jungle environment conditions.

The first logical constraint is related to set up a combat situation framework and its level of detail. These most typically occur when there is not sufficient information about the battle dynamics to simulate, or when a model is to be used to calculate a measure of effectiveness of analysis which may not be directly related to specific combat processes. As a result, in this research, the major path watercourse characteristics as well as height of riverine vegetation was considered constant, both in time and space dimensions, and whose values are simply estimates of the existent real-world entities. Also, since there is no information about the enemy behavior, its tactics, operational objectives, and available means to achieve them as well as their real capabilities, the worst scenario was modeled, in which enemy forces have total visibility of battlefield.

Although the model accurately calculates both safety routes and better start-time to perform a stealthy navigation to the deployed fight unit locations, these outcomes referenced the existence of solar radiation. Since the algorithm used in this research was a sun position calculator, the use of different environment light sources, such as luminosity of the moon, won't provide the same performance, for logical reasons. Therefore, this methodology is valid for travel performed during daylight.

As already mentioned, the dynamics of the watercourse network wasn't modeled. In the real world, the amount of variables that affect the aerial exposure level on the jungle environment is beyond the tree height and move features. The environmental

effect of fog at sunrise and sunset due to high humidity tropical rain forests, as well as the excessive condensation on dry seasons, was omitted, though both of them are low-visibility makers. Additionally, the river attributes (flow speed and depth) were also completely neglected in addition to the main riverine forest aspect concerning its fallen posture over streams, which reduce boat vulnerability due to large shadow areas originated near to its borders.

Another relevant aspect not modeled in this research is the return trip of the boat to the depot. The model ignores this action as well as its implications for future missions. Also, since the searcher has an omnidirectional sensing of observation, move evasive actions or deliberate route changes against the previous planned ones, after aerial enemy detection, were completely omitted.

Future Research

While this research serves to address some important questions related to stealthy supply navigation under jungle warfare constraints, it by no means answers all of them. Thus, suggestions for future analysis are the following:

- a) Keeping both a single-source and destination (combat unit), assess the performance of the Bellman-Ford algorithm in dealing with stealthy navigation problem;
- b) Increase the number of units deployed on battlefield and, as a result, evaluate the optimal start-time, boat dimensions;
- c) Also increase the number of different moves capable to support several locations, leaving the depot either simultaneously or at distinct times;

- d) Perform assessment under conditions of changing in time dependent environment features such as flow speed, on both direction and its intensity, and depth river, including seasonal alterations, which can affect boat transverse capability;
- e) Given a network, as well as the operations theater boundaries, evaluate the optimal fixed depot location able to minimize the total travel risk between an origin and the deployed fight forces;
- f) Include the moon luminosity influence on exposure level calculations during network night crossing;
- g) Conduct a random enemy aerial search strategy on the vulnerability evaluation, since the present study focused on omnidirectional sensing observer, which is a pessimistic as well as unrealistic (theoretical) construct;
- h) Develop other combat logistics effectiveness measures for assessing travel network vulnerability that include fuel consumption rate, defense posture, water searcher in addition to aerial ones.

Appendix A: Geographic Coordinates of the Theoretical Network Locations

| Nodes | | Geographic Latitude | | | Geographic Longitude | | |
|-------|---------|---------------------|--------|--------|----------------------|--------|--------|
| | | Degree | Minute | Second | Degree | Minute | Second |
| 1 | Node 01 | -1 | -8 | -33.39 | -62 | -18 | -2.93 |
| 2 | Node 02 | -1 | -8 | -56.77 | -62 | -20 | -10.73 |
| 3 | Node 03 | -1 | -9 | -20.87 | -62 | -18 | -14.87 |
| 4 | Node 04 | -1 | -10 | -10.27 | -62 | -16 | -27.98 |
| 5 | Node 05 | -1 | -9 | -38.05 | -62 | -16 | -19.46 |
| 6 | Node 06 | -1 | -8 | -30.17 | -62 | -15 | -30.58 |
| 7 | Node 07 | -1 | -11 | -50.28 | -62 | -16 | -18.18 |
| 8 | Node 08 | -1 | -9 | -50.01 | -62 | -14 | -17.58 |
| 9 | Node 09 | -1 | -8 | -47.25 | -62 | -14 | -2.39 |
| 10 | Node 10 | -1 | -10 | -57.86 | -62 | -14 | -29.54 |
| 11 | Node 11 | -1 | -12 | -12.48 | -62 | -14 | -38.15 |
| 12 | Node 12 | -1 | -10 | -17.27 | -62 | -12 | -42.80 |
| 13 | Node 13 | -1 | -12 | -48.08 | -62 | -14 | -53.47 |
| 14 | Node 14 | -1 | -13 | -35.56 | -62 | -15 | -2.00 |
| 15 | Node 15 | -1 | -14 | -19.68 | -62 | -14 | -45.10 |
| 16 | Node 16 | -1 | -14 | -19.83 | -62 | -12 | -53.10 |
| 17 | Node 17 | -1 | -13 | -57.84 | -62 | -12 | -19.15 |
| 18 | Node 18 | -1 | -11 | -47.40 | -62 | -11 | -31.28 |
| 19 | Node 19 | -1 | -15 | -58.30 | -62 | -12 | -58.26 |
| 20 | Node 20 | -1 | -9 | -41.88 | -62 | -10 | -8.37 |
| 21 | Node 21 | -1 | -18 | -9.03 | -62 | -11 | -52.29 |
| 22 | Node 22 | -1 | -15 | -29.66 | -62 | -10 | -32.27 |
| 23 | Node 23 | -1 | -14 | -42.42 | -62 | -7 | -35.71 |
| 24 | Node 24 | -1 | -11 | -37.50 | -62 | -6 | -56.56 |
| 25 | Node 25 | -1 | -10 | -56.82 | -62 | -6 | -25.95 |
| 26 | Node 26 | -1 | -18 | -15.82 | -62 | -10 | -14.37 |
| 27 | Node 27 | -1 | -17 | -14.76 | -62 | -4 | -55.59 |
| 28 | Node 28 | -1 | -16 | -46.10 | -62 | -8 | -59.06 |
| 29 | Node 29 | -1 | -16 | -54.72 | -62 | -6 | -33.52 |
| 30 | Node 30 | -1 | -19 | -29.02 | -62 | -7 | -22.95 |
| 31 | Node 31 | -1 | -18 | -31.40 | -62 | -6 | -45.54 |
| 32 | Node 32 | -1 | -15 | -24.97 | -62 | -5 | -54.04 |
| 33 | Node 33 | -1 | -14 | -41.00 | -62 | -4 | -51.02 |
| 34 | Node 34 | -1 | -12 | -0.55 | -62 | -5 | -18.47 |
| 35 | Node 35 | -1 | -12 | -11.75 | -62 | -4 | -32.33 |
| 36 | Node 36 | -1 | -14 | -19.11 | -62 | -2 | -42.22 |
| 37 | Node 37 | -1 | -15 | -25.17 | -62 | -3 | -43.39 |

| | | | | | | | |
|----|---------|----|-----|--------|-----|-----|--------|
| 38 | Node 38 | -1 | -16 | 28.01 | -62 | -2 | -59.34 |
| 39 | Node 39 | -1 | -18 | -43.43 | -62 | -4 | -56.95 |
| 40 | Node 40 | -1 | -19 | -55.78 | -62 | -4 | -58.65 |
| 41 | Node 41 | -1 | -20 | -35.41 | -62 | -5 | -32.12 |
| 42 | Node 42 | -1 | -20 | -47.91 | -62 | -5 | -56.56 |
| 43 | Node 43 | -1 | -17 | -7.34 | -62 | -1 | -15.74 |
| 44 | Node 44 | -1 | -18 | -14.14 | -62 | -1 | -47.97 |
| 45 | Node 45 | -1 | -22 | -21.48 | -62 | -2 | -43.31 |
| 46 | Node 46 | -1 | -21 | -31.52 | -62 | -1 | -0.17 |
| 47 | Node 47 | -1 | -20 | -59.15 | -62 | 0 | -42.50 |
| 48 | Node 48 | -1 | -15 | -56.90 | -61 | -58 | -28.26 |
| 49 | Node 49 | -1 | -17 | -53.75 | -61 | -59 | -36.82 |
| 50 | Node 50 | -1 | -18 | -31.37 | -62 | 0 | -7.76 |
| 51 | Node 51 | -1 | -18 | -10.76 | -61 | -55 | -56.94 |
| 52 | Node 52 | -1 | -20 | -59.00 | -61 | -57 | -13.60 |
| 53 | Node 53 | -1 | -22 | -50.83 | -61 | -58 | -56.76 |
| 54 | Node 54 | -1 | -23 | -34.97 | -61 | -59 | -35.09 |
| 55 | Node 55 | -1 | -22 | -15.64 | -61 | -56 | -23.47 |
| 56 | Node 56 | -1 | -21 | -19.71 | -61 | -55 | -39.29 |
| 57 | Node 57 | -1 | -20 | -11.71 | -61 | -54 | -39.91 |
| 58 | Node 58 | -1 | -23 | -55.82 | -61 | -55 | -33.35 |
| 59 | Node 59 | -1 | -22 | -48.18 | -61 | -53 | -44.36 |
| 60 | Node 60 | -1 | -23 | -44.12 | -61 | -53 | -56.14 |
| 61 | Node 61 | -1 | -24 | -31.23 | -61 | -54 | -4.97 |
| 62 | Node 62 | -1 | -23 | -23.71 | -61 | -50 | -24.02 |
| 63 | Node 63 | -1 | -24 | -7.87 | -61 | -50 | -21.08 |
| 64 | Node 64 | -1 | -25 | -0.86 | -61 | -50 | -29.91 |

Appendix B: Model Code

Option Explicit

Function radToDeg(angleRad)
'Convert Angles in Radians to ones in Degrees'

radToDeg = (180# * angleRad / Application.WorksheetFunction.pi())

End Function

Function degToRad(angleDeg)
'Convert Angles in Degrees to ones in Radians'

degToRad = (Application.WorksheetFunction.pi() * angleDeg / 180#)

End Function

Function calcJD(year, month, day)
'Calculate Julian Day from Calendary Day'

Dim A As Double 'Declarate Auxiliar Variable "A" to Calculate Julian Date'

Dim B As Double 'Declarate Auxiliar Variable "B" to Calculate Julian Date'

Dim JD As Double 'Declarate the Julian Day'

'Month: January = 1; Day: from 1 to 31'

If (month <= 2) Then

year = year - 1

month = month + 12

End If

A = Application.WorksheetFunction.Floor(year / 100, 1)

B = 2 - A + Application.WorksheetFunction.Floor(A / 4, 1)

JD = Application.WorksheetFunction.Floor(365.25 * (year + 4716), 1) +

Application.WorksheetFunction.Floor(30.6001 * (month + 1), 1) + day + B - 1524.5

calcJD = JD

'Correct Years and Months values to the Current Calendary pattern'

If month = 13 Then

month = 1

year = year + 1

End If

If month = 14 Then

month = 2

year = year + 1

End If

End Function

Function calcTimeJulianCent(JD)
'Calculate the Number of Julian centuries since J2000.0'

Dim t As Double 'Declare the number of Julian centuries since J2000.0'

t = (JD - 2451545#) / 36525#
calcTimeJulianCent = t

End Function

Function calcJDFromJulianCent(t)
'Convert J2000.0 to Julian Date'

Dim JD As Double 'Declare the Julian Day'

JD = t * 36525# + 2451545#
calcJDFromJulianCent = JD

End Function

Function calcGeomMeanLongSun(t)
'Calculate the Geometric Mean Longitude of the Sun in Degrees'

Dim l0 As Double 'Declare the Geometric Mean Longitude of the Sun'

l0 = 280.46646 + t * (36000.76983 + 0.0003032 * t)
Do
If (l0 <= 360) And (l0 >= 0) Then Exit Do
If l0 > 360 Then l0 = l0 - 360
If l0 < 0 Then l0 = l0 + 360
Loop
calcGeomMeanLongSun = l0

End Function

Function calcGeomMeanAnomalySun(t)
'Calculate the Geometric Mean Anomaly of the Sun in Degrees'

Dim m As Double 'Declare Geometric Mean Anomaly of the Sun'

m = 357.52911 + t * (35999.05029 - 0.0001537 * t)
calcGeomMeanAnomalySun = m

End Function

Function calcEccentricityEarthOrbit(t)
'Calculate the Eccentricity of the Earth's orbit'

Dim e As Double 'Declare the Eccentricity of the Earth's Orbit'

```
e = 0.016708634 - t * (0.000042037 + 0.0000001267 * t)
calcEccentricityEarthOrbit = e
```

End Function

Function calcSunEqOfCenter(t)

'Calculate the Equation of Center of the Sun in Degrees'

```
Dim m As Double      'Declare Geometric Mean Anomaly of the Sun in Degrees'
Dim mrad As Double   'Declare Geometric Mean Anomaly of the Sun in Radians'
Dim sinm As Double   'Declare the Sine of the "m" Angle'
Dim sin2m As Double  'Declare the Sin of the "2m" Angle'
Dim sin3m As Double  'Declare the Sin of the "3m" Angle'
Dim c As Double      'Declare the Equation of Center of the Sun in Degrees'
```

```
m = calcGeomMeanAnomalySun(t)
mrad = degToRad(m)
sinm = Sin(mrad)
sin2m = Sin(mrad + mrad)
sin3m = Sin(mrad + mrad + mrad)
```

```
c = sinm * (1.914602 - t * (0.004817 + 0.000014 * t)) + sin2m * (0.019993 - 0.000101 * t) +
sin3m * 0.000289
calcSunEqOfCenter = c
```

End Function

Function calcSunTrueLong(t)

'Calculate the True Longitude of the Sun in Degrees'

```
Dim l0 As Double     'Declare the Geometric Mean Longitude of the Sun'
Dim c As Double      'Declare the Equation of Center of the Sun in Degrees'
Dim O As Double      'Declare the True Longitude of the Sun in Degrees'
```

```
l0 = calcGeomMeanLongSun(t)
c = calcSunEqOfCenter(t)
```

```
O = l0 + c
calcSunTrueLong = O
```

End Function

Function calcSunTrueAnomaly(t)

'Calculate the True Anomaly of the Sun in Degrees'

```
Dim m As Double      'Declare Geometric Mean Anomaly of the Sun in Degrees'
Dim c As Double      'Declare the Equation of Center of the Sun in Degrees'
Dim v As Double      'Declare the True Anomaly of the Sun in Degrees'
```

```
m = calcGeomMeanAnomalySun(t)
c = calcSunEqOfCenter(t)
```

```
v = m + c
calcSunTrueAnomaly = v
```

End Function

Function calcSunRadVector(t)

'Calculate the Distance to the Sun in Astronomical Units (UA)'

```
Dim v As Double    'Declare the True Anomaly of the Sun in Degrees'
Dim e As Double    'Declare the Eccentricity of the Earth's orbit'
Dim R As Double    'Declare the Distance to the Sun in Astronomical Units (UA)'
```

```
v = calcSunTrueAnomaly(t)
e = calcEccentricityEarthOrbit(t)
```

```
R = (1.000001018 * (1 - e * e)) / (1 + e * Cos(degToRad(v)))
calcSunRadVector = R
```

End Function

Function calcSunApparentLong(t)

'Calculate the Apparent Longitude of the Sun in Degrees'

```
Dim O As Double    'Declare the True Longitude of the Sun in Degrees'
Dim omega As Double 'Declare the Geocentric Longitude of the Sun in Degree'
Dim lambda As Double 'Declare the Apparent Longitude of the Sun in Degrees'
```

```
O = calcSunTrueLong(t)
```

```
omega = 125.04 - 1934.136 * t
lambda = O - 0.00569 - 0.00478 * Sin(degToRad(omega))
calcSunApparentLong = lambda
```

End Function

Function calcMeanObliquityOfEcliptic(t)

'Calculate the Mean Obliquity of the Ecliptic'

```
Dim seconds As Double    'Declare seconds'
Dim e0 As Double         'Declare the Mean Obliquity of the Ecliptic'
```

```
seconds = 21.448 - t * (46.815 + t * (0.00059 - t * (0.001813)))
e0 = 23# + (26# + (seconds / 60#)) / 60#
calcMeanObliquityOfEcliptic = e0
```

End Function

Function calcObliquityCorrection(t)
'Calculate the Corrected Obliquity of the Ecliptic in Degrees'

Dim e0 As Double 'Declare the Mean Obliquity of the Ecliptic'
Dim omega As Double 'Declare the Geocentric Longitude of the Sun in Degree'
Dim e As Double 'Declare the Eccentricity of the Earth's orbit'

e0 = calcMeanObliquityOfEcliptic(t)

omega = 125.04 - 1934.136 * t
e = e0 + 0.00256 * Cos(degToRad(omega))
calcObliquityCorrection = e

End Function

Function calcSunRtAscension(t)
'Calculate the Right Ascension of the Sun in Degrees'

Dim e As Double 'Declare the Eccentricity of the Earth's orbit'
Dim lambda As Double 'Declare the Apparent Longitude of the Sun in Degrees'
Dim tananum As Double 'Declare the Numerator of the Auxiliar Variable "a"
Dim tanadenom As Double 'Declare the Denominator of the Auxiliar Variable "a"
Dim alpha As Double 'Declare the Right Ascension of the Sun in Degrees'

e = calcObliquityCorrection(t)
lambda = calcSunApparentLong(t)

tananum = (Cos(degToRad(e)) * Sin(degToRad(lambda)))
tanadenom = (Cos(degToRad(lambda)))

'Original NOAA code using javascript Math.Atan2(y,x) convention:
'a) var alpha = radToDeg(Math.atan2(tananum, tanadenom));'
'b) alpha = radToDeg(Application.WorksheetFunction.Atan2(tananum, tanadenom)).'

'Translated using Excel VBA Application.WorksheetFunction.Atan2(x,y) convention:
alpha = radToDeg(Application.WorksheetFunction.Atan2(tanadenom, tananum))

calcSunRtAscension = alpha

End Function

Function calcSunDeclination(t)
'Calculate the Declination of the Sun in Degrees'

Dim e As Double 'Declare the Eccentricity of the Earth's orbit'
Dim lambda As Double 'Declare the Apparent Longitude of the Sun in Degrees'
Dim sint As Double 'Declare the Auxiliar Variable which represents the produt of Earth's
orbit Eccentricity and the Sun Longitude'
Dim theta As Double 'Declare the Declination of the Sun in Degrees'

```

e = calcObliquityCorrection(t)
lambda = calcSunApparentLong(t)

sint = Sin(degToRad(e)) * Sin(degToRad(lambda))
theta = radToDeg(Application.WorksheetFunction.Asin(sint))
calcSunDeclination = theta

```

End Function

Function calcEquationOfTime(t)
'Calculate the Equation of Time in Degrees'

```

Dim epsilon As Double 'Declare the Corrected Obliquity of the Ecliptic in Degrees
Dim l0 As Double 'Declare the Geometric Mean Longitude of the Sun'
Dim e As Double 'Declare the Eccentricity of the Earth's Orbit'
Dim m As Double 'Declare the Geometric Mean Anomaly of the Sun in Degrees'
Dim y As Double 'Declare the Auxiliary Variable whic represents the Tangent of
Epsilon Value'

Dim sin2l0 As Double 'Declare the Sine Squared of the Geometric Mean Longitude of the
Sun'
Dim sinm As Double 'Declare the Sine of the Geometric Mean Anomaly of the Sun'
Dim cos2l0 As Double 'Declare the Cosine Squared of the Geometric Mean Longitude of
the Sun'
Dim sin4l0 As Double 'Declare the Cosine Fourth of the Geometric Mean Longitude of the
Sun'
Dim sin2m As Double 'Declare the Sin Squared of the Geometric Mean Anomaly of the
Sun'
Dim Etime As Double 'Declare the Equation of Time in Degrees'

```

```

epsilon = calcObliquityCorrection(t)
l0 = calcGeomMeanLongSun(t)
e = calcEccentricityEarthOrbit(t)
m = calcGeomMeanAnomalySun(t)

```

```

y = Tan(degToRad(epsilon) / 2#)
y = y ^ 2

```

```

sin2l0 = Sin(2# * degToRad(l0))
sinm = Sin(degToRad(m))
cos2l0 = Cos(2# * degToRad(l0))
sin4l0 = Sin(4# * degToRad(l0))
sin2m = Sin(2# * degToRad(m))

```

```

Etime = y * sin2l0 - 2# * e * sinm + 4# * e * y * sinm * cos2l0 - 0.5 * y * y * sin4l0 - 1.25 * e
* e * sin2m

```

```

calcEquationOfTime = radToDeg(Etime) * 4#

```

End Function

Function calcHourAngleDawn(lat, solarDec, solardepression)
'Calculate the Local Hour Angle of the Sun at Dawn in Radians'

Dim latRad As Double 'Declare the Local Latitude in Radians'
Dim sdRad As Double 'Declare the Solar Declination Angle in Degrees'
Dim HAarg As Double 'Declare the Auxiliar Variable to Calculate Local Hour Angle of t
the Sun at Dawn'
Dim HA As Double 'Declare the Local Hour Angle of the Sun at Dawn'

latRad = degToRad(lat)
sdRad = degToRad(solarDec)

HAarg = (Cos(degToRad(90 + solardepression)) / (Cos(latRad) * Cos(sdRad)) - Tan(latRad) *
Tan(sdRad))

HA = (Application.WorksheetFunction.Acos(Cos(degToRad(90 + solardepression)) /
(Cos(latRad) * Cos(sdRad)) - Tan(latRad) * Tan(sdRad)))

calcHourAngleDawn = HA

End Function

Function calcHourAngleSunrise(lat, solarDec)
'Calculate the Local Hour Angle of the Sun at Sunrise in Radians'

Dim latRad As Double 'Declare the Local Latitude in Radians'
Dim sdRad As Double 'Declare the Solar Declination Angle in Radians'
Dim HAarg As Double 'Declare the Auxiliar Variable to Calculate Local Hour Angle of the
Sun at Sunrise'
Dim HA As Double 'Declare the Local Hour Angle of the Sun at Sunrise in Radians'

latRad = degToRad(lat)
sdRad = degToRad(solarDec)

HAarg = (Cos(degToRad(90.833)) / (Cos(latRad) * Cos(sdRad)) - Tan(latRad) * Tan(sdRad))

HA = (Application.WorksheetFunction.Acos(Cos(degToRad(90.833)) / (Cos(latRad) *
Cos(sdRad)) - Tan(latRad) * Tan(sdRad)))

calcHourAngleSunrise = HA

End Function

Function calcHourAngleSunset(lat, solarDec)
'Calculate the Local Hour Angle of the Sun at Sunset in Radians'

Dim latRad As Double 'Declare the Local Latitude in Radians'
Dim sdRad As Double 'Declare the Solar Declination Angle in Radians'
Dim HAarg As Double 'Declare the Auxiliar Variable to Calculate Local Hour Angle of

Dim HA As Double 'the Sun at Sunset'
'Declarate the Local Hour Angle of the Sun at Sunset in Radians'

latRad = degToRad(lat)
sdRad = degToRad(solarDec)

HAarg = (Cos(degToRad(90.833)) / (Cos(latRad) * Cos(sdRad)) - Tan(latRad) * Tan(sdRad))

HA = (Application.WorksheetFunction.Acos(Cos(degToRad(90.833)) / (Cos(latRad) *
Cos(sdRad)) - Tan(latRad) * Tan(sdRad)))

calcHourAngleSunset = -HA

End Function

Function calcHourAngleDusk(lat, solarDec, solardepression)
'Calculate the Local Hour Angle of the Sun at Dusk'

Dim latRad As Double 'Declarate the Local Latitude in Radians
Dim sdRad As Double 'Declarate the Solar Declination Angle in Radians'
Dim HAarg As Double 'Declarate the Auxiliar Variable to Calculate Local Hour Angle of the
Sun at Dusk'
Dim HA As Double 'Declarate the Local Hour Angle of the Sun at Dusk in Radians

latRad = degToRad(lat)
sdRad = degToRad(solarDec)

HAarg = (Cos(degToRad(90 + solardepression)) / (Cos(latRad) * Cos(sdRad)) - Tan(latRad) *
Tan(sdRad))

HA = (Application.WorksheetFunction.Acos(Cos(degToRad(90 + solardepression)) /
(Cos(latRad) * Cos(sdRad)) - Tan(latRad) * Tan(sdRad)))

calcHourAngleDusk = -HA

End Function

Function calcDawnUTC(JD, latitude, longitude, solardepression)
'Calculate the Universal Coordinated Time of Dawn for a given Day and Location'

Dim t As Double 'Declarate the number of Julian centuries since J2000.0'
Dim eqtime As Double 'Declarate the Equation of Time in Degrees'
Dim solarDec As Double 'Declarate the Solar Declination in Degrees'
Dim hourangle As Double 'Declarate the Local Hour Angle at Sunrise, given a Latitude and
Solar Declination'
Dim delta As Double 'Declarate the difference between Local Longitude and Local
Hour Angle at Sunrise, in Radians'
Dim timeDiff As Double 'Declarate the 4 times Delta Value'
Dim timeUTC As Double 'Declarate the Universal Coordinated Time of Dawn in Minutes'

Dim newt As Double 'Declarate the new "t"

t = calcTimeJulianCent(JD)

'First pass to approximate Sunrise'

eqtime = calcEquationOfTime(t)

solarDec = calcSunDeclination(t)

hourangle = calcHourAngleSunrise(latitude, solarDec)

delta = longitude - radToDeg(hourangle)

timeDiff = 4 * delta

timeUTC = 720 + timeDiff - eqtime

'Second pass includes fractional Julian Day in Gamma calculation'

newt = calcTimeJulianCent(calcJDFromJulianCent(t) + timeUTC / 1440#)

eqtime = calcEquationOfTime(newt)

solarDec = calcSunDeclination(newt)

hourangle = calcHourAngleDawn(latitude, solarDec, solardepression)

delta = longitude - radToDeg(hourangle)

timeDiff = 4 * delta

timeUTC = 720 + timeDiff - eqtime

calcDawnUTC = timeUTC

End Function

Function calcSunriseUTC(JD, latitude, longitude)

'Calculate the Universal Coordinated Time (UTC) of Sunrise for the given Day and at the given Location on Earth'

Dim t As Double

'Declarate the number of Julian centuries since J2000.0'

Dim eqtime As Double

'Declarate the Equation of Time in Minutes'

Dim solarDec As Double

'Declarate the Solar Declination in Degrees'

Dim hourangle As Double

'Declarate the Local Hour Angle at Sunrise, given a Latitude and Solar Declination'

Dim delta As Double

'Declarate the difference between Local Longitude and Local Hour Angle at Sunrise, in Radians'

Dim timeDiff As Double

'Declarate 4 times Delta Value'

Dim timeUTC As Double

'Declarate the Universal Coordinated Time of Sunrise in Minutes'

Dim newt As Double

'Declarate the new "t"'

t = calcTimeJulianCent(JD)

'First pass to approximate Sunrise'

eqtime = calcEquationOfTime(t)

solarDec = calcSunDeclination(t)

hourangle = calcHourAngleSunrise(latitude, solarDec)

```

delta = longitude - radToDeg(hourangle)
timeDiff = 4 * delta
timeUTC = 720 + timeDiff - eqtime

```

'Second pass includes fractional Julian Day in Gamma calculation'

```

newt = calcTimeJulianCent(calcJDFromJulianCent(t) + timeUTC / 1440#)
eqtime = calcEquationOfTime(newt)
solarDec = calcSunDeclination(newt)
hourangle = calcHourAngleSunrise(latitude, solarDec)
delta = longitude - radToDeg(hourangle)
timeDiff = 4 * delta
timeUTC = 720 + timeDiff - eqtime

```

```

calcSunriseUTC = timeUTC

```

End Function

Function calcSolNoonUTC(t, longitude)

'Calculate the the Universal Coordinated Time of Solar Noon Declination for the given Day and at the given Location on Earth'

```

Dim newt As Double           'Declare the new "t"'
Dim eqtime As Double        'Declare the Equation of Time in Minutes'
Dim solarNoonDec As Double  'Declare the Solar Noon Declination'
Dim solNoonUTC As Double    'Declare the Solar Noon Declination at Universal
                             Coordinated Time'

```

```

newt = calcTimeJulianCent(calcJDFromJulianCent(t) + 0.5 + longitude / 360#)

```

```

eqtime = calcEquationOfTime(newt)
solarNoonDec = calcSunDeclination(newt)
solNoonUTC = 720 + (longitude * 4) - eqtime

```

```

calcSolNoonUTC = solNoonUTC

```

End Function

Function calcSunsetUTC(JD, latitude, longitude)

'Calculate the the Universal Coordinated Time of Sunset for the given Day and at the given Location on Earth'

```

Dim t As Double             'Declare the number of Julian centuries since J2000.0'
Dim eqtime As Double       'Declare the Equation of Time in Minutes'
Dim solarDec As Double     'Declare the Solar Declination Angle'
Dim hourangle As Double    'Declare the Local Hour Angle in Degrees at Sunset'
Dim delta As Double        'Declare the Difference between Local Longitude and Local
                             Hour Angle in Radians'
Dim timeDiff As Double     'Declare 4 times Delta Value'
Dim timeUTC As Double      'Declare the Universal Coordinated Time of Sunset in Minutes'

```



```
timeDiff = 4 * delta
timeUTC = 720 + timeDiff - eqtime
```

'First pass used to include fractional day in Gamma calculation'

```
newt = calcTimeJulianCent(calcJDFromJulianCent(t) + timeUTC / 1440#)
eqtime = calcEquationOfTime(newt)
solarDec = calcSunDeclination(newt)
hourangle = calcHourAngleDusk(latitude, solarDec, solardepression)
```

```
delta = longitude - radToDeg(hourangle)
timeDiff = 4 * delta
timeUTC = 720 + timeDiff - eqtime
```

```
calcDuskUTC = timeUTC
```

End Function

Function dawn(lat, lon, year, month, day, timezone, dlstime, solardepression)
'Calculate the Time of Dawn, in days, for a given Date and Location'

```
Dim longitude As Double      'Declare the Local Longitude in Degrees'
Dim latitude As Double       'Declare the Local Latitude in Degrees'
Dim JD As Double             'Declare the Julian Day'
Dim riseTimeGMT As Double    'Declare the Sunrise for this date'
Dim riseTimeLST As Double    'Declare the Sunrise for this date adjusting for the Time
                              Zone and Daylight Savings, in Minutes'
```

'Change the Sign Convention for Longitude from Negative to Positive in Western Hemisphere'

```
longitude = lon * -1
latitude = lat
If (latitude > 89.8) Then latitude = 89.8
If (latitude < -89.8) Then latitude = -89.8
```

```
JD = calcJD(year, month, day)
```

```
riseTimeGMT = calcDawnUTC(JD, latitude, longitude, solardepression)
```

'Adjusting for Time Zone and Daylight Savings Time in Minutes

```
riseTimeLST = riseTimeGMT + (60 * timezone) + (dlstime * 60)
```

'Convert the Dawn from Minutes to Days'

```
dawn = riseTimeLST / 1440
```

End Function

Function sunrise(lat, lon, year, month, day, timezone, dlstime)
'Calculate the Sunrise, in days, for a given Date and Location'

```
Dim longitude As Double      'Declare the Local Longitude in Degrees'
```

Dim latitude As Double 'Declarate the Local Latitude in Degrees'
 Dim JD As Double 'Declarate the Julian Day'
 Dim riseTimeGMT As Double 'Declarate the Sunrise time for this date'
 Dim riseTimeLST As Double 'Declarate the Sunrise on this date adjusting for the Time
 Zone and Daylight Savings, in Minutes'

'Change the Sign Convention for Longitude from Negative to Positive in Western Hemisphere'

longitude = lon * -1
 latitude = lat
 If (latitude > 89.8) Then latitude = 89.8
 If (latitude < -89.8) Then latitude = -89.8

JD = calcJD(year, month, day)

riseTimeGMT = calcSunriseUTC(JD, latitude, longitude)

'Adjusting for Time Zone and Daylight Savings Time in Minutes

riseTimeLST = riseTimeGMT + (60 * timezone) + (dlstime * 60)

'Convert the Sunrise from Minutes to Days'

sunrise = riseTimeLST / 1440

End Function

Function solarnoon(lat, lon, year, month, day, timezone, dlstime)

'Calculate the Universal Coordinated Time of Solar Noon, in days, for the given Day at the given
 Location on Earth'

Dim longitude As Double 'Declarate the Local Longitude in Degrees'
 Dim latitude As Double 'Declarate the Local Latitude in Degrees'
 Dim JD As Double 'Declarate the Julian Day'
 Dim t As Double 'Declarate the number of Julian centuries since J2000.0'
 Dim newt As Double 'Declarate the new "t"
 Dim eqtime As Double 'Declarate the Equation of Time'
 Dim solarNoonDec As Double 'Declarate the Solar Noon Declination Angle'
 Dim solNoonUTC As Double 'Declarate the Solar Noon on Universal Coordinated Time'

'Change the Sign Convention for Longitude from Negative to Positive in Western Hemisphere'

longitude = lon * -1
 latitude = lat
 If (latitude > 89.8) Then latitude = 89.8
 If (latitude < -89.8) Then latitude = -89.8

JD = calcJD(year, month, day)

t = calcTimeJulianCent(JD)

newt = calcTimeJulianCent(calcJDFromJulianCent(t) + 0.5 + longitude / 360#)

eqtime = calcEquationOfTime(newt)

```
solarNoonDec = calcSunDeclination(newt)
solNoonUTC = 720 + (longitude * 4) - eqtime
```

'Adjusting for Time Zone and Daylight Savings Time in Minutes

```
solarnoon = solNoonUTC + (60 * timezone) + (dlstime * 60)
```

'Convert the Sunrise from Minutes to Days'

```
solarnoon = solarnoon / 1440
```

End Function

Function sunset(lat, lon, year, month, day, timezone, dlstime)

'Calculate the time of Sunset, in days, for the given Date and Location.

Dim longitude As Double

'Declare the Local Longitude in Degrees'

Dim latitude As Double

'Declare the Local Latitude in Degrees'

Dim JD As Double

'Declare the Julian Day'

Dim setTimeGMT As Double

'Declare the Sunset time of this Date'

Dim setTimeLST As Double

'Declare the the Sunset time for the given Date and Location.

'Change the Sign Convention for Longitude from Negative to Positive in Western Hemisphere'

```
longitude = lon * -1
```

```
latitude = lat
```

```
If (latitude > 89.8) Then latitude = 89.8
```

```
If (latitude < -89.8) Then latitude = -89.8
```

```
JD = calcJD(year, month, day)
```

```
setTimeGMT = calcSunsetUTC(JD, latitude, longitude)
```

'Adjusting for Time Zone and Daylight Savings Time in Minutes

```
setTimeLST = setTimeGMT + (60 * timezone) + (dlstime * 60)
```

'Convert the Sunrise from Minutes to Days'

```
sunset = setTimeLST / 1440
```

End Function

Function dusk(lat, lon, year, month, day, timezone, dlstime, solardepression)

'Calculate the Time of Dusk, in days, for a given Date and Location'

Dim longitude As Double

'Declare the Local Longitude in Degrees'

Dim latitude As Double

'Declare the Local Latitude in Degrees'

Dim JD As Double

'Declare the Julian Day'

Dim setTimeGMT As Double

'Declare the Sunset for this day'

Dim setTimeLST As Double

'Declare the the Time of Dusk, in days, for a given Date and Location'

'Change the Sign Convention for Longitude from Negative to Positive in Western Hemisphere'

longitude = lon * -1

latitude = lat

If (latitude > 89.8) Then latitude = 89.8

If (latitude < -89.8) Then latitude = -89.8

JD = calcJD(year, month, day)

setTimeGMT = calcDuskUTC(JD, latitude, longitude, solardepression)

'Adjusting for Time Zone and Daylight Savings Time in Minutes

setTimeLST = setTimeGMT + (60 * timezone) + (dlstime * 60)

'Convert the Sunrise from Minutes to Days'

dusk = setTimeLST / 1440

End Function

Function solarazimuth(lat, lon, year, month, day, hours, minutes, seconds, timezone, dlstime)

'Calculate the Solar Azimuth Angle (Degrees from North) for a given Date and Location.

| | |
|-----------------------------|---|
| Dim longitude As Double | 'Declare the Local Longitude in Degrees' |
| Dim latitude As Double | 'Declare the Local Latitude in Degrees' |
| Dim zone As Double | 'Declare the Time Zone in Hours' |
| Dim daySavings As Double | 'Declare the Daylight Savings (0 = no or 1 = yes)' |
| Dim hh As Double | 'Declare the Local Hour' |
| Dim mm As Double | 'Declare the Local Minute' |
| Dim ss As Double | 'Declare the Local Second' |
| Dim timenow As Double | 'Declare the Time in Hours (GMT)' |
| Dim JD As Double | 'Declare the Julian Day' |
| Dim t As Double | 'Declare the number of Julian centuries since J2000.0' |
| Dim R As Double | 'Declare the Distance to the Sun in Astronomical Units (UA)' |
| Dim alpha As Double | 'Declare the Right Ascension of the Sun in Degrees' |
| Dim theta As Double | 'Declare the Declination of the Sun in Degrees' |
| Dim Etime As Double | 'Declare the Equation of Time in Radians' |
| Dim eqtime As Double | 'Declare the Equation of Time in Degrees' |
| Dim solarDec As Double | 'Declare the Solar Declination Angle' |
| Dim earthRadVec As Double | 'Declare the Earth's Radius Vector' |
| Dim solarTimeFix As Double | 'Declare the Corrected Solar Time, in Minutes, using Equation of Time' |
| Dim trueSolarTime As Double | 'Declare the True Solar Time in Minutes' |
| Dim hourangle As Double | 'Declare the Local Hour Angle at Sunrise, given a Latitude and Solar Declination, in Degrees' |
| Dim harad As Double | 'Declare the Local Hour Angle in Radians' |
| Dim csz As Double | 'Declare the Solar Zenith in Radians' |
| Dim zenith As Double | 'Declare the Solar Zenith in Degrees' |
| Dim azDenom As Double | 'Declare the Denominator' |
| Dim azRad As Double | 'Declare the Solar Azimuth in Radians' |
| Dim azimuth As Double | 'Declare the Solar Azimuth Angle' |

| | |
|------------------------------------|---|
| Dim exoatmElevation As Double | 'Declare the Differente between 90 degrees and Zenith' |
| Dim step1 As Double | 'Declare the Auxiliar Variable "step1"' |
| Dim step2 As Double | 'Declare the Auxiliar Variable "step2"' |
| Dim step3 As Double | 'Declare the Auxiliar Variable "step3"' |
| Dim refractionCorrection As Double | 'Declare the Refraction Correction' |
| Dim te As Double | 'Declare the Tangent of the Differente between 90 degrees and Zenith' |
| Dim solarzen As Double | 'Declare the Solar Zenith after the Refraction Correction' |

'Change the Sign Convention for Longitude from Negative to Positive in Western Hemisphere'

```

longitude = lon * -1
latitude = lat
If (latitude > 89.8) Then latitude = 89.8
If (latitude < -89.8) Then latitude = -89.8

```

'Change Time Zone to Positive hours in Western Hemisphere'

```

zone = timezone * -1
daySavings = dlstime * 60
hh = hours - (daySavings / 60)
mm = minutes
ss = seconds

timenow = hh + mm / 60 + ss / 3600 + zone

```

```

JD = calcJD(year, month, day)
t = calcTimeJulianCent(JD + timenow / 24#)
R = calcSunRadVector(t)
alpha = calcSunRtAscension(t)
theta = calcSunDeclination(t)
Etime = calcEquationOfTime(t)

```

```

eqtime = Etime
solarDec = theta
earthRadVec = R

```

```

solarTimeFix = eqtime - 4# * longitude + 60# * zone
trueSolarTime = hh * 60# + mm + ss / 60# + solarTimeFix

```

```

Do While (trueSolarTime > 1440)
    trueSolarTime = trueSolarTime - 1440
Loop

```

```

hourangle = trueSolarTime / 4# - 180#
If (hourangle < -180) Then hourangle = hourangle + 360#

```

```

harad = degToRad(hourangle)

```

```

csz = Sin(degToRad(latitude)) * Sin(degToRad(solarDec)) + Cos(degToRad(latitude)) *
Cos(degToRad(solarDec)) * Cos(harad)

If (csz > 1#) Then
    csz = 1#
    ElseIf (csz < -1#) Then
        csz = -1#
    End If

zenith = radToDeg(Application.WorksheetFunction.Acos(csz))

azDenom = (Cos(degToRad(latitude)) * Sin(degToRad(zenith)))

If (Abs(azDenom) > 0.001) Then
    azRad = ((Sin(degToRad(latitude)) * Cos(degToRad(zenith))) - Sin(degToRad(solarDec))) /
azDenom
    If (Abs(azRad) > 1#) Then
        If (azRad < 0) Then
            azRad = -1#
        Else
            azRad = 1#
        End If
    End If

azimuth = 180# - radToDeg(Application.WorksheetFunction.Acos(azRad))

If (hourangle > 0#) Then
    azimuth = -azimuth
End If
Else
    If (latitude > 0#) Then
        azimuth = 180#
    Else
        azimuth = 0#
    End If
End If
If (azimuth < 0#) Then
    azimuth = azimuth + 360#
End If

exoatmElevation = 90# - zenith

If (exoatmElevation > 85#) Then
    refractionCorrection = 0#
Else
    te = Tan(degToRad(exoatmElevation))
    If (exoatmElevation > 5#) Then
        refractionCorrection = 58.1 / te - 0.07 / (te * te * te) + 0.000086 / (te * te * te * te * te)
    ElseIf (exoatmElevation > -0.575) Then

```



```

    step1 = (-12.79 + exoatmElevation * 0.711)
    step2 = (103.4 + exoatmElevation * (step1))
    step3 = (-518.2 + exoatmElevation * (step2))
    refractionCorrection = 1735# + exoatmElevation * (step3)
Else: refractionCorrection = -20.774 / te
End If
    refractionCorrection = refractionCorrection / 3600#
End If

solarzen = zenith - refractionCorrection

solarazimuth = azimuth

```

End Function

Function solarelevation(lat, lon, year, month, day, hours, minutes, seconds, timezone, dlstime)
'Calculate the Solar Elevation or Altitude (Degrees from North) for a given Date, Time, and Location'

| | |
|-------------------------------|---|
| Dim longitude As Double | 'Declare the Local Longitude in Degrees' |
| Dim latitude As Double | 'Declare the Local Latitude in Degrees' |
| Dim zone As Double | 'Declare the Time Zone in Hours' |
| Dim daySavings As Double | 'Declare the Daylight Savings (0 = no or 1 = yes)' |
| Dim hh As Double | 'Declare the Local Hour' |
| Dim mm As Double | 'Declare the Local Minute' |
| Dim ss As Double | 'Declare the Local Second' |
| Dim timenow As Double | 'Declare the Time in Hours (GMT)' |
| Dim JD As Double | 'Declare the Julian Day' |
| Dim t As Double | 'Declare the number of Julian centuries since J2000.0' |
| Dim R As Double | 'Declare the Distance to the Sun in Astronomical Units (UA)' |
| Dim alpha As Double | 'Declare the Right Ascension of the Sun in Degrees' |
| Dim theta As Double | 'Declare the Declination of the Sun in Degrees' |
| Dim Etime As Double | 'Declare the Equation of Time in Radians' |
| Dim eqtime As Double | 'Declare the Equation of Time in Degrees' |
| Dim solarDec As Double | 'Declare the Solar Declination Angle' |
| Dim earthRadVec As Double | 'Declare the Earth's Radius Vector' |
| Dim solarTimeFix As Double | 'Declare the Corrected Solar Time, in Minutes, using Equation of Time' |
| Dim trueSolarTime As Double | 'Declare the True Solar Time in Minutes' |
| Dim hourangle As Double | 'Declare the Local Hour Angle at Sunrise, given a Latitude and Solar Declination, in Degrees' |
| Dim harad As Double | 'Declare the Local Hour Angle in Radians' |
| Dim csz As Double | 'Declare the Solar Zenith in Radians' |
| Dim zenith As Double | 'Declare the Solar Zenith in Degrees' |
| Dim azDenom As Double | 'Declare the Denominator' |
| Dim azRad As Double | 'Declare the Solar Azimuth in Radians' |
| Dim azimuth As Double | 'Declare the Solar Azimuth Angle' |
| Dim exoatmElevation As Double | 'Declare the Different between 90 degrees and Zenith' |

| | |
|------------------------------------|--|
| Dim step1 As Double | 'Declare the Auxiliar Variable "step1"' |
| Dim step2 As Double | 'Declare the Auxiliar Variable "step2"' |
| Dim step3 As Double | 'Declare the Auxiliar Variable "step3"' |
| Dim refractionCorrection As Double | 'Declare the Refraction Correction' |
| Dim te As Double | 'Declare the Tangent of the Different between 90 degrees and Zenith' |
| Dim solarzen As Double | 'Declare the Solar Zenith after the Refraction Correction' |

'Change the Sign Convention for Longitude from Negative to Positive in Western Hemisphere'

```

longitude = lon * -1
latitude = lat
If (latitude > 89.8) Then latitude = 89.8
If (latitude < -89.8) Then latitude = -89.8

```

'Change the Time Zone to Positive hours in Western Hemisphere'

```

zone = timezone * -1
daySavings = dlstime * 60
hh = hours - (daySavings / 60)
mm = minutes
ss = seconds

timenow = hh + mm / 60 + ss / 3600 + zone

```

```

JD = calcJD(year, month, day)
t = calcTimeJulianCent(JD + timenow / 24#)
R = calcSunRadVector(t)
alpha = calcSunRtAscension(t)
theta = calcSunDeclination(t)
Etime = calcEquationOfTime(t)

```

```

eqtime = Etime
solarDec = theta
earthRadVec = R

```

```

solarTimeFix = eqtime - 4# * longitude + 60# * zone
trueSolarTime = hh * 60# + mm + ss / 60# + solarTimeFix

```

```

Do While (trueSolarTime > 1440)
  trueSolarTime = trueSolarTime - 1440
Loop

```

```

hourangle = trueSolarTime / 4# - 180#
If (hourangle < -180) Then hourangle = hourangle + 360#

```

```

harad = degToRad(hourangle)

```

```

csz = Sin(degToRad(latitude)) * Sin(degToRad(solarDec)) + Cos(degToRad(latitude)) *
Cos(degToRad(solarDec)) * Cos(harad)

```

```

If (csz > 1#) Then
    csz = 1#
ElseIf (csz < -1#) Then
    csz = -1#
End If

zenith = radToDeg(Application.WorksheetFunction.Acos(csz))

azDenom = (Cos(degToRad(latitude)) * Sin(degToRad(zenith)))

If (Abs(azDenom) > 0.001) Then
    azRad = ((Sin(degToRad(latitude)) * _
        Cos(degToRad(zenith))) - _
        Sin(degToRad(solarDec))) / azDenom
If (Abs(azRad) > 1#) Then
    If (azRad < 0) Then
        azRad = -1#
    Else
        azRad = 1#
    End If
End If

    azimuth = 180# - radToDeg(Application.WorksheetFunction.Acos(azRad))

If (hourangle > 0#) Then
    azimuth = -azimuth
End If
Else
    If (latitude > 0#) Then
        azimuth = 180#
    Else
        azimuth = 0#
    End If
End If
If (azimuth < 0#) Then
    azimuth = azimuth + 360#
End If

exoatmElevation = 90# - zenith

If (exoatmElevation > 85#) Then
    refractionCorrection = 0#
Else
    te = Tan(degToRad(exoatmElevation))
    If (exoatmElevation > 5#) Then
        refractionCorrection = 58.1 / te - 0.07 / (te * te * te) + 0.000086 / (te * te * te * te * te)
    ElseIf (exoatmElevation > -0.575) Then
        step1 = (-12.79 + exoatmElevation * 0.711)

```

```

step2 = (103.4 + exoatmElevation * (step1))
step3 = (-518.2 + exoatmElevation * (step2))
refractionCorrection = 1735# + exoatmElevation * (step3)
Else
refractionCorrection = -20.774 / te
End If
refractionCorrection = refractionCorrection / 3600#
End If

solarzen = zenith - refractionCorrection

solarelevation = 90# - solarzen

```

End Function

Sub solarposition(lat, lon, year, month, day, hours, minutes, seconds, timezone, dlstime, solarazimuth, solarelevation)

'Calculate the Solar Position given a Date, Time and Location'

| | |
|-------------------------------|---|
| Dim longitude As Double | 'Declare the Local Longitude in Degrees' |
| Dim latitude As Double | 'Declare the Local Latitude in Degrees' |
| Dim zone As Double | 'Declare the Time Zone in Hours' |
| Dim daySavings As Double | 'Declare the Daylight Savings (0 = no or 1 = yes)' |
| Dim hh As Double | 'Declare the Local Hour' |
| Dim mm As Double | 'Declare the Local Minute' |
| Dim ss As Double | 'Declare the Local Second' |
| Dim timenow As Double | 'Declare the Time in Hours (GMT)' |
| Dim JD As Double | 'Declare the Julian Day' |
| Dim t As Double | 'Declare the number of Julian centuries since J2000.0' |
| Dim R As Double | 'Declare the Distance to the Sun in Astronomical Units (UA)' |
| Dim alpha As Double | 'Declare the Right Ascension of the Sun in Degrees' |
| Dim theta As Double | 'Declare the Declination of the Sun in Degrees' |
| Dim Etime As Double | 'Declare the Equation of Time in Radians' |
| Dim eqtime As Double | 'Declare the Equation of Time in Degrees' |
| Dim solarDec As Double | 'Declare the Solar Declination Angle' |
| Dim earthRadVec As Double | 'Declare the Earth's Radius Vector' |
| Dim solarTimeFix As Double | 'Declare the Corrected Solar Time, in Minutes, using Equation of Time' |
| Dim trueSolarTime As Double | 'Declare the True Solar Time in Minutes' |
| Dim hourangle As Double | 'Declare the Local Hour Angle at Sunrise, given a Latitude and Solar Declination, in Degrees' |
| Dim harad As Double | 'Declare the Local Hour Angle in Radians' |
| Dim csz As Double | 'Declare the Solar Zenith in Radians' |
| Dim zenith As Double | 'Declare the Solar Zenith in Degrees' |
| Dim azDenom As Double | 'Declare the Denominator' |
| Dim azRad As Double | 'Declare the Solar Azimuth in Radians' |
| Dim azimuth As Double | 'Declare the Solar Azimuth Angle' |
| Dim exoatmElevation As Double | 'Declare the Difference between 90 degrees and Zenith' |

| | |
|------------------------------------|---|
| Dim step1 As Double | 'Declare the Auxiliar Variable "step1"' |
| Dim step2 As Double | 'Declare the Auxiliar Variable "step2"' |
| Dim step3 As Double | 'Declare the Auxiliar Variable "step3"' |
| Dim refractionCorrection As Double | 'Declare the Refraction Correction' |
| Dim te As Double | 'Declare the Tangent of the Differente between 90 degrees and Zenith' |
| Dim solarzen As Double | 'Declare the Solar Zenith after the Refraction Correction' |

'Change the Sign Convention for Longitude from Negative to Positive in Western Hemisphere'

```

longitude = lon * -1
latitude = lat
If (latitude > 89.8) Then latitude = 89.8
If (latitude < -89.8) Then latitude = -89.8

```

'Change the Time Zone to Positive hours in Western Hemisphere'

```

zone = timezone * -1
daySavings = dlstime * 60
hh = hours - (daySavings / 60)
mm = minutes
ss = seconds

timenow = hh + mm / 60 + ss / 3600 + zone

```

```

JD = calcJD(year, month, day)
t = calcTimeJulianCent(JD + timenow / 24#)
R = calcSunRadVector(t)
alpha = calcSunRtAscension(t)
theta = calcSunDeclination(t)
Etime = calcEquationOfTime(t)

```

```

eqtime = Etime
solarDec = theta
earthRadVec = R

```

```

solarTimeFix = eqtime - 4# * longitude + 60# * zone
trueSolarTime = hh * 60# + mm + ss / 60# + solarTimeFix

```

```

Do While (trueSolarTime > 1440)
  trueSolarTime = trueSolarTime - 1440
Loop

```

```

hourangle = trueSolarTime / 4# - 180#
If (hourangle < -180) Then hourangle = hourangle + 360#

```

```

harad = degToRad(hourangle)

```

```

csz = Sin(degToRad(latitude)) * Sin(degToRad(solarDec)) + Cos(degToRad(latitude)) *
Cos(degToRad(solarDec)) * Cos(harad)

```

```

If (csz > 1#) Then
    csz = 1#
ElseIf (csz < -1#) Then
    csz = -1#
End If

zenith = radToDeg(Application.WorksheetFunction.Acos(csz))

azDenom = (Cos(degToRad(latitude)) * Sin(degToRad(zenith)))

If (Abs(azDenom) > 0.001) Then
    azRad = ((Sin(degToRad(latitude)) * _
        Cos(degToRad(zenith))) - _
        Sin(degToRad(solarDec))) / azDenom
    If (Abs(azRad) > 1#) Then
        If (azRad < 0) Then
            azRad = -1#
        Else
            azRad = 1#
        End If
    End If
End If

azimuth = 180# - radToDeg(Application.WorksheetFunction.Acos(azRad))

If (hourangle > 0#) Then
    azimuth = -azimuth
End If
Else
    If (latitude > 0#) Then
        azimuth = 180#
    Else
        azimuth = 0#
    End If
End If
If (azimuth < 0#) Then
    azimuth = azimuth + 360#
End If

exoatmElevation = 90# - zenith

If (exoatmElevation > 85#) Then
    refractionCorrection = 0#
Else
    te = Tan(degToRad(exoatmElevation))
    If (exoatmElevation > 5#) Then
        refractionCorrection = 58.1 / te - 0.07 / (te * te * te) + 0.000086 / (te * te * te * te * te)
    ElseIf (exoatmElevation > -0.575) Then
        step1 = (-12.79 + exoatmElevation * 0.711)
        step2 = (103.4 + exoatmElevation * (step1))
    End If
End If

```

```

    step3 = (-518.2 + exoatmElevation * (step2))
    refractionCorrection = 1735# + exoatmElevation * (step3)
Else
    refractionCorrection = -20.774 / te
End If
    refractionCorrection = refractionCorrection / 3600#
End If

```

```

solarzen = zenith - refractionCorrection

```

```

solarazimuth = azimuth
solarelevation = 90# - solarzen

```

```

End Sub

```

Function travel_risk(start_point As Double, end_point As Integer, JD As Double) As Double
'Calculate the total risk during travel on the Military network'

```

Dim i As Long           'Declare the Start Point'
Dim j As Integer       'Declare the End Point'
Dim hour As Double    'Declare Hours'
Dim min As Double     'Declare Minutes'
Dim sec As Double     'Declare Seconds'
Dim day As Double     'Declarate Day'
Dim month As Double   'Declare Month'
Dim year As Double    'Declare Year'
Dim LY As Integer     'Declare Leap Year'
Dim TZ As Integer     'Declare Time-Zone'
Dim D As Integer      'Declare Daylight Savings'
Dim avg_lat As Double 'Declare Average Latitude in Radians'
Dim avg_lon As Double 'Declare Average Longitude in Radians'
Dim shadow_proj As Double 'Declare Solar Projection'
Dim diff_AZij_solAZ As Double 'Declare the Difference between Path Azimuth and Solar Azimuth'

Dim SolAz As Double   'Declare Solar Azimuth Angle'
Dim AZij As Double    'Declare Azimuth between Points "i" and "j"'
Dim Sol_alt As Double 'Declare Solar Altitude'
Dim SolAz_d As Double 'Declare Solar Azimuth in Degrees'
Dim Real_shadow As Double 'Declare Real Shadow Lenght'
Dim virtual_shadow As Double 'Declare Virtual Shadow Lenght'
Dim tree As Double    'Declare Riverine Forest Height'
Dim boat_speed As Double 'Declare Boat Speed'
Dim boat_width As Double 'Declare Boat Width'
Dim river_speed As Double 'Declare River Speed'
Dim ratio_earth As Double 'Declare Ratio Earth'
Dim pi As Double      'Declare the Mathematical Constant Pi'
Dim e As Double       'Declare the Mathematical Constant Euler's number e'
Dim point(65, 10) As Double 'Point[i][1] Latitute degrees at point "i"'
                          'Point[i][2] Latitute minutes at point "i"'

```

'Point[i][3] Latitude seconds at point "i"
 'Point[i][4] Longitude degrees at point "i"
 'Point[i][5] Longitude minutes at point "i"
 'Point[i][6] Longitude seconds at point "i"
 'Point[i][7] Solar Azimuth at point "i"
 'Point[i][8] Solar Altitude at point "i"
 'Point[i][9] Geocentric Latitude of point "i"
 'Point[i][10] Longitude of Point "i"

Dim lat_d As Double 'Declare Degrees of Latitude of Point "i"
 Dim lat_m As Double 'Declare Minutes of Latitude of Point "i"
 Dim lat_s As Double 'Declare Seconds of Latitude of Point "i"
 Dim lat As Double 'Declare Latitude of Point "i" in Radians'
 Dim lon_d As Double 'Declare Degrees of Latitude of Point "i"
 Dim lon_m As Double 'Declare Minutes of Latitude of Point "i"
 Dim lon_s As Double 'Declare Seconds of Latitude of Point "i"
 Dim lon As Double 'Declare Longitude of Point "i" in Radians'
 Dim Rad_lon_i As Double 'Declare Longitude of Point "i" in Radians'
 Dim Rad_lon_j As Double 'Declare Longitude of Point "j" in Radians'
 Dim Rad_lat_i As Double 'Declare Latitude of Point "i" in Radians'
 Dim Rad_lat_j As Double 'Declare Latitude of Point "j" in Radians'
 Dim DD_lat_i As Double 'Declare Latitude of Point "i" in Degrees'
 Dim DD_lon_i As Double 'Declare Longitude of Point "i" in Degrees'
 Dim DD_lat_j As Double 'Declare Latitude of Point "j" in Degrees'
 Dim DD_lon_j As Double 'Declare Longitude of Point "j" in Degrees'
 Dim LC As Double 'Declare Longitude Correction'
 Dim RL As Double 'Declare Reference Longitude'
 Dim COSS As Double 'Declare Cosine of Distance between Points "i" and "j"
 Dim ACOSS As Double 'Declare ArcCosine of Distance between Points "i" and "j"
 Dim DISTS As Double 'Declare Cosine of Distance between Points "i" and "j"
 Dim travel_time As Double 'Declare travel time between points "i" and "j"
 e = Exp(1)

i = start_point 'Declare the start point'
 j = end_point 'Declare the end point'

'Get variables'

TZ = Worksheets("Input").Cells(2, 6).Value 'Get Time-Zone'
 LY = Worksheets("Input").Cells(6, 4).Value 'Get Leap Year'
 D = Worksheets("Input").Cells(2, 8).Value 'Get Daylight Savings'
 hour = Worksheets("Input").Cells(3, 6).Value 'Get Hour'
 min = Worksheets("Input").Cells(4, 6).Value 'Get Minute'
 sec = Worksheets("Input").Cells(5, 6).Value 'Get Second'
 day = Worksheets("Input").Cells(3, 4).Value 'Get Day'
 month = Worksheets("Input").Cells(4, 4).Value 'Get Month'
 year = Worksheets("Input").Cells(5, 4).Value 'Get Year'
 boat_width = Worksheets("Input").Cells(7, 4).Value 'Get Boat width'
 boat_speed = Worksheets("Input").Cells(8, 4).Value 'Get Boat Speed'
 ratio_earth = Worksheets("Input").Cells(9, 4).Value 'Get the Ratio of Earth'

pi = Application.WorksheetFunction.pi()

'Get the Mathematical constant Pi'

'Calculate Geocentric Latitude and Longitude of Start Point in Radians'

point(i, 1) = Worksheets("Input").Cells(12 + i, 4).Value 'Get Degrees of Latitude of Point "i"'

lat_d = point(i, 1)

point(i, 2) = Worksheets("Input").Cells(12 + i, 5).Value 'Get Minutes of Latitude of Point "i"'

lat_m = point(i, 2)

point(i, 3) = Worksheets("Input").Cells(12 + i, 6).Value 'Get Seconds of Latitude of Point "i"'

lat_s = point(i, 3)

point(i, 4) = Worksheets("Input").Cells(12 + i, 7).Value 'Get Degrees of Longitude of Point "i"'

lon_d = point(i, 4)

point(i, 5) = Worksheets("Input").Cells(12 + i, 8).Value 'Get Minutes of Longitude of Point "i"'

lon_m = point(i, 5)

point(i, 6) = Worksheets("Input").Cells(12 + i, 9).Value 'Get Seconds of Longitude of Point "i"'

lon_s = point(i, 6)

'Calculate Latitude of Start Point in Degrees'

DD_lat_i = lat_d + lat_m / 60 + lat_s / 3600

'Calculate Latitude of Start Point in Radians'

Rad_lat_i = WorksheetFunction.Radians(DD_lat_i)

'Calculate Longitude of Start Point in Degrees'

DD_lon_i = lon_d + lon_m / 60 + lon_s / 3600

'Calculate Longitude of Start Point in Radians'

Rad_lon_i = WorksheetFunction.Radians(DD_lon_i)

point(i, 10) = Rad_lon_i

'Calculate Geocentric Latitude of Start Point in Radians'

lat = Atn((1 - (1 / 2983) ^ 2) * Tan(Rad_lat_i))

point(i, 9) = lat

'Calculate Geocentric Latitude and Longitude of End Point in Radians'

point(j, 1) = Worksheets("Input").Cells(12 + j, 4).Value 'Get Degrees of Latitude of Point "i"'

lat_d = point(j, 1)

point(j, 2) = Worksheets("Input").Cells(12 + j, 5).Value 'Get Minutes of Latitude of Point "i"'

lat_m = point(j, 2)

point(j, 3) = Worksheets("Input").Cells(12 + j, 6).Value 'Get Seconds of Latitude of Point "i"'

lat_s = point(j, 3)

point(j, 4) = Worksheets("Input").Cells(12 + j, 7).Value 'Get Degrees of Longitude of Point "i"'

lon_d = point(j, 4)

point(j, 5) = Worksheets("Input").Cells(12 + j, 8).Value 'Get Minutes of Longitude of Point "i"'

lon_m = point(j, 5)

point(j, 6) = Worksheets("Input").Cells(12 + j, 9).Value 'Get Seconds of Longitude of Point "i"'

lon_s = point(j, 6)

'Calculate Latitude of End Point in Degrees'

DD_lat_j = lat_d + lat_m / 60 + lat_s / 3600

'Calculate Latitude of End Point in Radians'

Rad_lat_j = WorksheetFunction.Radians(DD_lat_j)

'Calculate Longitude of End Point in Degrees'

DD_lon_j = lon_d + lon_m / 60 + lon_s / 3600

'Calculate Longitude of End Point in Radians'

Rad_lon_j = WorksheetFunction.Radians(DD_lon_j)

point(j, 10) = Rad_lon_j

'Calculate Geocentric Latitude of End Point in Radians'

lat = Atn((1 - (1 / 2983) ^ 2) * Tan(Rad_lat_j))

point(j, 9) = lat

'Calculate Cosine of Distance between Points i and j'

COSS = Sin(point(j, 9)) * Sin(point(i, 9)) + Cos(point(j, 9)) * Cos(point(i, 9)) * Cos(point(j, 10) - point(i, 10))

'Calculate Distance between Points i and j'

ACOSS = Application.WorksheetFunction.Acos(COSS)

'Calculate Distance between Points i and j in miles'

DISTS = ACOSS * ratio_earth

'Calculate Path Azimuth (between Points i and j)'

AZij = Application.WorksheetFunction.Asin(Sin(pi / 2 - point(j, 9)) * Sin(point(j, 10) - point(i, 10)) / Sin(ACOSS))

If AZij < 0 Then AZij = AZij + 2 * pi

'Calculate Path Azimuth in Degrees'

Dim AZij_d As Double

AZij_d = AZij * 180 / pi

'Get information about hight riverine forest'

tree = Worksheets("Input").Cells(12 + i, 12 + j).Value 'Get Riverine Forest Height'

'Calculate Average Latitude between Points i and j'

avg_lat = (Rad_lat_i + Rad_lat_j) / 2

'Calculate Solar Azimuth'

SolAz_d = solarazimuth(DD_lat_j, DD_lon_j, year, month, day, hour, min, sec, TZ, D)

SolAz = SolAz_d * pi / 180

'Calculate Solar Altitude'

Dim Sol_alt_d As Double

Sol_alt_d = solarelevation(DD_lat_j, DD_lon_j, year, month, day, hour, min, sec, TZ, D)

$Sol_alt = Sol_alt_d * \pi / 180$

'Calculate the Difference between Solar Azimuth and Path Azimuth'

'Both Solar and Path Azimuths are in first quadrant'

```
If AZij <= pi / 2 And SolAz <= pi / 2 Then
  If SolAz > AZij Then
    diff_AZij_solAZ = SolAz - AZij
  Else: diff_AZij_solAZ = AZij - SolAz
  End If
End If
```

'Path Azimuth is in the first quadrant and Solar Azimuth is in the second one'

```
If AZij <= pi / 2 And SolAz >= pi / 2 And SolAz <= pi Then
  If (SolAz - pi / 2) < AZij Then
    diff_AZij_solAZ = SolAz - AZij
  Else: diff_AZij_solAZ = pi - SolAz + AZij
  End If
End If
```

'Path Azimuth is in the first quadrant and Solar Azimuth is in the third one'

```
If AZij <= pi / 2 And SolAz >= pi And SolAz <= pi Then
  If (SolAz - pi) > AZij Then
    diff_AZij_solAZ = SolAz - pi - AZij
  Else: diff_AZij_solAZ = AZij - (SolAz - pi)
  End If
End If
```

'Path Azimuth is in the first quadrant and Solar Azimuth is in the fourth one'

```
If AZij <= pi / 2 And SolAz >= 3 * pi / 2 Then
  If (SolAz - 3 * pi / 2) < AZij Then
    diff_AZij_solAZ = SolAz - AZij - pi
  Else: diff_AZij_solAZ = 2 * pi - SolAz + AZij
  End If
End If
```

'Solar Azimuth is in the first quadrant and Path Azimuth is in the second one'

```
If AZij >= pi / 2 And AZij <= pi And SolAz <= pi / 2 Then
  If (AZij - pi / 2) < SolAz Then
    diff_AZij_solAZ = pi - AZij + SolAz
  Else: diff_AZij_solAZ = AZij - SolAz
  End If
End If
```

'Solar Azimuth is in the first quadrant and Path Azimuth is in the third one'

```
If AZij >= pi And AZij <= 3 * pi / 2 And SolAz <= pi / 2 Then
  If (AZij - pi) < SolAz Then
    diff_AZij_solAZ = AZij - pi - SolAz
  Else: diff_AZij_solAZ = SolAz - (AZij - pi)
  End If
End If
```

End If
End If

'Both Solar Azimuth and Path Azimuth are in the second quadrant'

If AZij >= pi / 2 And AZij <= pi And SolAz >= pi / 2 And SolAz <= pi Then
If AZij < SolAz Then
diff_AZij_solAZ = SolAz - AZij
Else: diff_AZij_solAZ = AZij - SolAz
End If
End If

'Solar Azimuth is in second quadrant and Path Azimuth is in the third one'

If AZij >= pi And AZij <= 3 * pi / 2 And SolAz >= pi / 2 And SolAz <= pi Then
If AZij > SolAz Then
diff_AZij_solAZ = AZij - SolAz
Else: diff_AZij_solAZ = SolAz - (AZij - pi)
End If
End If

'Both Solar and Path Azimuths are in the third quadrant'

If AZij >= pi And AZij <= 3 * pi / 2 And SolAz >= pi And SolAz <= 3 * pi / 2 Then
If SolAz > AZij Then
diff_AZij_solAZ = SolAz - AZij
Else: diff_AZij_solAZ = AZij - SolAz
End If
End If

'Path Azimuths is in the third quadrant and Solar Azimuth is in the fourth one'

If AZij <= 3 * pi / 2 And AZij >= pi And SolAz >= 3 * pi / 2 Then
If SolAz > AZij Then
diff_AZij_solAZ = SolAz - AZij
Else: diff_AZij_solAZ = (2 * pi - SolAz) + (AZij - pi)
End If
End If

'Both Path and Solar Azimuths are in the fourth quadrant'

If AZij >= 3 * pi / 2 And SolAz >= 3 * pi / 2 Then
If SolAz > AZij Then
diff_AZij_solAZ = SolAz - AZij
Else: diff_AZij_solAZ = AZij - SolAz
End If
End If

'Calculate Risk between Points i and j'

'Calculate Shadow length'

If Sol_alt < pi / 2 Or Sol_alt > pi / 2 Then
shadow_proj = tree / Tan(Sol_alt)
If Sol_alt = pi / 2 Then shadow_proj = 0

End If

'Calculate Virtual Shadow Length'

virtual_shadow = shadow_proj * Sin(diff_AZij_solAZ)

'Calculate Real Shadow Length'

Real_shadow = Application.WorksheetFunction.Max(0, virtual_shadow)

If Real_shadow / boat_width > 1 Then

travel_risk = 0

ElseIf Real_shadow / boat_width > 0 Then

travel_risk = Real_shadow / boat_width

ElseIf Real_shadow / boat_width = 0 Then

travel_risk = 1

End If

'Current time'

Dim cur_time As Double

Dim DS As Double

DS = Sheets("input").Cells(2, 8)

TZ = Sheets("input").Cells(2, 6)

cur_time = (JD - Int(JD)) * 24 + 12 - DS + TZ

If cur_time > 24 Then cur_time = cur_time - 24

If cur_time < Sheets("input").Cells(2, 10) Then

travel_risk = 0

ElseIf cur_time > Sheets("input").Cells(4, 10) Then

travel_risk = 0

End If

End Function

Sub Dijkstra_time()

Dim Rad_lat_i As Double

Dim Rad_lat_j As Double

Dim Rad_lon_i As Double

Dim Rad_lon_j As Double

Dim DD_lat_i As Double

Dim DD_lon_i As Double

Dim DD_lat_j As Double

Dim DD_lon_j As Double

Dim COSS As Double

Dim ACOSS As Double

Dim DISTs As Double

Dim lat_d As Double

Dim lat_m As Double

'Declare Latitude of Point "i" in Radians'

'Declare Latitude of Point "j" in Radians'

'Declare Longitude of Point "i" in Radians'

'Declare Longitude of Point "j" in Radians'

'Declare Latitude of Point "i" in degrees'

'Declare Longitude of Point "i" in Degrees'

'Declare Latitude of Point "j" in Degrees'

'Declare Longitude of Point "j" in Degrees'

'Declare Cosine of Distance between Points "i" and "j"'

'Declare ArcCosine of Distance between Points "i" and "j"'

'Declare Cosine of Distance between Points "i" and "j"'

'Declare Degrees of Latitude of Point "i"'

'Declare Minutes of Latitude of Point "i"'

| | |
|---------------------------|--|
| Dim lat_s As Double | 'Declare Seconds of Latitude of Point "i"' |
| Dim lat As Double | 'Declare Latitude of Point "i" in Radians' |
| Dim lon_d As Double | 'Declare Degrees of Latitude of Point "i"' |
| Dim lon_m As Double | 'Declare Minutes of Latitude of Point "i"' |
| Dim lon_s As Double | 'Declare Seconds of Latitude of Point "i"' |
| Dim lon As Double | 'Declare Longitude of Point "i" in Radians' |
| Dim point() As Double | 'Point[i][1] Latitude degrees at point "i"' |
| | 'Point[i][2] Latitude minutes at point "i"' |
| | 'Point[i][3] Latitude seconds at point "i"' |
| | 'Point[i][4] Longitude degrees at point "i"' |
| | 'Point[i][5] Longitude minutes at point "i"' |
| | 'Point[i][6] Longitude seconds at point "i"' |
| | 'Point[i][7] Solar Azimuth at point "i"' |
| | 'Point[i][8] Solar Altitude at point i' |
| | 'Point[i][9] Geocentric Latitude of point i' |
| | 'Point[i][10] Longitude of point i' |
| | |
| Dim boat_speed As Double | 'Declare the Boat Speed' |
| Dim boat_width As Double | 'Declare the Boat Width' |
| Dim river_speed As Double | 'Declare the River Speed' |
| Dim ratio_earth As Double | 'Declare the Ratio Earth' |
| Dim pi As Double | 'Declare the Mathematical Constant Pi' |
| Dim hour As Double | 'Declare Hours' |
| Dim min As Double | 'Declare Minutes' |
| Dim sec As Double | 'Declare Seconds' |
| Dim day As Double | 'Declarate Day' |
| Dim month As Double | 'Declare Month' |
| Dim year As Double | 'Declare Year' |
| Dim JD As Double | 'Declare the Julian Date' |
| Dim start_time As Double | 'Declare Start Time' |
| Dim UT As Double | 'Declare Universal Time' |
| Dim DS As Integer | 'Declare Daylight Saving' |
| Dim t As Double | 'Declare Auxiliar Variable "t"' |
| Dim numnodes As Long | 'Declare the Total Number of Nodes' |
| Dim Q() As Double | 'Declare the Set Q' |
| Dim adj() As Integer | 'Declare the Adjacent Node' |
| Dim adj_risk() As Double | 'Declare the Risk of Adjacent Node' |
| Dim adj_time() As Double | 'Declare the Time between Adjacent Nodes' |
| Dim previous() As Long | 'Declare the Previous Node' |
| Dim risk() As Double | 'Declare the Risk' |
| Dim time() As Double | 'Declare the Time' |
| Dim old_time() As Double | 'Declare the Old Time' |
| Dim gap As Integer | 'Declare the Gap' |
| Dim k As Integer | 'Declare the Auxiliar Variable "k"' |
| Dim m As Integer | 'Declare the Auxiliar Variable "m"' |
| Dim i As Integer | 'Declare the Node "i"' |
| Dim j As Integer | 'Declare the Node "j"' |
| Dim infity As Double | 'Declare the Infinity value' |
| Dim count As Double | 'Declare the Counter' |

| | |
|---------------------------|--|
| Dim TZ As Double | 'Declare the Time-Zone' |
| Dim Source As Integer | 'Declare the Source Node' |
| Dim temp1 As Double | 'Declare the Auxiliar Variable "temp 1"' |
| Dim temp2 As Double | 'Declare the Auxiliar Variable "temp 2"' |
| Dim temptime As Double | 'Declare the Auxiliar Variable "temptime"' |
| Dim alt_risk As Double | 'Declare the Auxiliar Variable "Alt Risk"' |
| Dim sink As Integer | 'Declare the Auxiliar Variable "sink"' |
| Dim rownum As Integer | 'Declare Row Number' |
| Dim firstnode As Integer | 'Declare the First Node to be Visited' |
| Dim secondnode As Integer | 'Declare the Second Node to be Visited' |
| Dim temp As Integer | 'Declare Auxiliar Variable "temp"' |

'Count Number of Nodes'

```
numnodes = 13
While Sheets("Input").Cells(numnodes, 2) <> ""
    numnodes = numnodes + 1
Wend
numnodes = numnodes - 13
Sheets("output").Range("A1:E65000").ClearContents
```

```
Sheets("output").Range("J2:n5000").ClearContents
```

'Redimension variables'

| | |
|--|--|
| ReDim Q(numnodes, 2) As Double | 'Redimension of number of nodes' |
| ReDim adj(numnodes, numnodes) As Integer | 'Redimension of the Adjacent Node' |
| ReDim adj_risk(numnodes, numnodes) As Double | 'Redimension of the Risk of Adjacent Node' |
| ReDim adj_time(numnodes, numnodes) As Double | 'Redimension of the Time related to the Adjacent Node' |
| ReDim previous(numnodes) As Long | 'Redimension of the Previous Node' |
| ReDim risk(numnodes) As Double | 'Redimension of the Risk' |
| ReDim time(numnodes) As Double | 'Redimension of the Time' |
| ReDim old_time(numnodes) As Double | 'Redimension of the Old Time' |
| ReDim point(numnodes, 10) | 'Redimension of the Point Number' |

'Get variables'

| | |
|---|------------------------------|
| TZ = Worksheets("Input").Cells(2, 6).Value | 'Get Time Zone' |
| DS = Worksheets("Input").Cells(2, 8).Value | 'Get Daylight Savings' |
| hour = Worksheets("Input").Cells(3, 6).Value | 'Get Hour' |
| min = Worksheets("Input").Cells(4, 6).Value | 'Get Minute' |
| sec = Worksheets("Input").Cells(5, 6).Value | 'Get Second' |
| day = Worksheets("Input").Cells(3, 4).Value | 'Get Day' |
| month = Worksheets("Input").Cells(4, 4).Value | 'Get Month' |
| year = Worksheets("Input").Cells(5, 4).Value | 'Get Year' |
| boat_width = Worksheets("Input").Cells(7, 4).Value | 'Get the Boat Width' |
| boat_speed = Worksheets("Input").Cells(8, 4).Value | 'Get the Boat Speed' |
| ratio_earth = Worksheets("Input").Cells(9, 4).Value | 'Get the Ratio of the Earth' |
| pi = Application.WorksheetFunction.pi() | 'Get the pi value' |

For i = 1 To numnodes

'Calculate Geocentric Latitude and Longitude of Start Point in Radians'

```
point(i, 1) = Worksheets("Input").Cells(12 + i, 4).Value 'Get Degrees of Latitude of Point "i"'
lat_d = point(i, 1)
point(i, 2) = Worksheets("Input").Cells(12 + i, 5).Value 'Get Minutes of Latitude of Point "i"'
lat_m = point(i, 2)
point(i, 3) = Worksheets("Input").Cells(12 + i, 6).Value 'Get Seconds of Latitude of Point "i"'
lat_s = point(i, 3)
point(i, 4) = Worksheets("Input").Cells(12 + i, 7).Value 'Get Degrees of Longitude of Point "i"'
lon_d = point(i, 4)
point(i, 5) = Worksheets("Input").Cells(12 + i, 8).Value 'Get Minutes of Longitude of Point "i"'
lon_m = point(i, 5)
point(i, 6) = Worksheets("Input").Cells(12 + i, 9).Value 'Get Seconds of Longitude of Point "i"'
lon_s = point(i, 6)
```

'Calculate Latitude of Start Point in Degrees'

```
DD_lat_i = lat_d + lat_m / 60 + lat_s / 3600
```

'Calculate Latitude of Start Point in Radians'

```
Rad_lat_i = WorksheetFunction.Radians(DD_lat_i)
```

'Calculate Longitude of Start Point in Degrees'

```
DD_lon_i = lon_d + lon_m / 60 + lon_s / 3600
```

'Calculate Longitude of Start Point in Radians'

```
Rad_lon_i = WorksheetFunction.Radians(DD_lon_i)
point(i, 10) = Rad_lon_i
```

'Calculate Geocentric Latitude of Start Point in Radians'

```
lat = Atn((1 - (1 / 2983) ^ 2) * Tan(Rad_lat_i))
point(i, 9) = lat
```

Next i

```
infty = 9999999
```

'Get adjacency matrix and put in adj(I,j)

```
count = 81
While Sheets("Input").Cells(count, 2) <> ""
adj(Sheets("Input").Cells(count, 2), Sheets("Input").Cells(count, 3)) = 1
adj(Sheets("Input").Cells(count, 3), Sheets("Input").Cells(count, 2)) = 1
count = count + 1
Wend
```

'Initialize Variables'

'Calculate Universal Time'

```
If (hour + min / 60 + sec / 3600 + DS - TZ) < 0 Then
    UT = (hour + min / 60 + sec / 3600 + DS - TZ) + 24
ElseIf (hour + min / 60 + sec / 3600 + DS - TZ) > 24 Then
```



```

    UT = (hour + min / 60 + sec / 3600 + DS - TZ) - 24
Else
    UT = (hour + min / 60 + sec / 3600 + DS - TZ)
End If

```

'Calculate the Julian Date'

```

JD = 367 * year - Int(7 * (year + Int((month + 9) / 12)) / 4) - Int(3 * (Int((year + (month - 9) / 7) / 100) + 1) / 4) + Int(275 * month / 9) + day + 1721028.5 + UT / 24

```

```

start_time = JD

```

```

Source = InputBox("Enter number of node to start at", "Start Node", 1) 'Get start node

```

```

Sheets("input").Cells(2, 10) = (sunrise(radToDeg(point(Source, 9)), radToDeg(point(Source, 10)), year, month, day, TZ, DS)) * 24

```

```

Sheets("input").Cells(3, 10) = (solarnoon(radToDeg(point(Source, 9)), radToDeg(point(Source, 10)), year, month, day, TZ, DS)) * 24

```

```

Sheets("input").Cells(4, 10) = (sunset(radToDeg(point(Source, 9)), radToDeg(point(Source, 10)), year, month, day, TZ, DS)) * 24

```

```

For i = 0 To numnodes
    'Initialization Procedures'
    Q(i, 1) = i           'Put all nodes in Q'
    Q(i, 2) = infty     'Unknown distance function from source to vertice "v"'
    risk(i) = infty     'Total risk of shortest path to node "i"'
    previous(i) = infty 'Node from which traveled to node "i" in optimal path from source'
    time(i) = infty     'Travel time to node "i"'
    old_time(i) = start_time 'Travel time to node "i"'
    time(Source) = start_time 'Set source start time to beginin time'
    time(0) = start_time 'Set time at beginning to begin time'
Next i

```

'Start the Algorithm'

```

risk(Source) = 0           'Distance from source to source'

```

```

Q(Source, 2) = 0

```

```

Q(0, 2) = -1 * infty

```

```

previous(Source) = 0

```

```

Do
    'The main loop'

```

'Sort Q by risk'

```

gap = (numnodes - 1) / 2

```

```

While (gap > 0)

```

```

    For k = gap To numnodes

```

```

        For m = k - gap To 0 Step -gap

```

```

            If (Q(m, 2) > Q(m + gap, 2)) Then

```

```

                temp2 = Q(m, 2)

```

```

                temp1 = Q(m, 1)

```

```

                Q(m, 2) = Q(m + gap, 2)

```

```

                Q(m + gap, 2) = temp2

```

```

                Q(m, 1) = Q(m + gap, 1)

```

```

        Q(m + gap, 1) = temp1
    End If
Next m
Next k
gap = gap / 2
Wend

If Q(1, 2) = infity Then
Exit Do          'All remaining vertices are inaccessible from source'
End If
Q(1, 2) = infity      'Remove "u" from Q sets dist to infinity so wont appear in sort'

'Removes "u" from adjacency matrix for next operation
For i = 1 To numnodes
    adj(Q(1, 1), i) = 0
Next i

'For each neighbor "v" of "u": where "v" has not yet been removed from Q.'
For i = 1 To numnodes
If adj(i, Q(1, 1)) = 1 Then

'Compute risk for time(q(1,1)) based on coming from node Q(1,1) to node "i".

    'Calculate Cosine of Distance between Points "i" and "j"'
    COSS = Sin(point(i, 9)) * Sin(point(Q(1, 1), 9)) + Cos(point(i, 9)) * Cos(point(Q(1, 1),
9)) * Cos(point(i, 10) - point(Q(1, 1), 10))

    'Calculate Distance between Points "i" and "j"'
    ACOSS = Application.WorksheetFunction.Acos(COSS)

    'Calculate Distance between Points "i" and "j" in miles'
    DISTS = ACOSS * ratio_earth

    temptime = time(Q(1, 1)) + (DISTS / boat_speed) / 24
    alt_risk = risk(Q(1, 1)) + travel_risk(Q(1, 1), i, temptime)

    If temptime < time(i) Then      'Relax (u,v,a)'
        old_time(i) = temptime
        time(i) = temptime
        previous(i) = Q(1, 1)

        For j = 1 To numnodes
            If Q(j, 1) = i Then Q(j, 2) = time(i)
        Next j
        risk(i) = alt_risk
    End If
End If
Next i
Loop Until numnodes < 0 ' loop until all nodes have been evaluated

```

'Get apth risk and time traveled'

```
Sheets("output").Cells(1, 1) = "Fastest Path"  
Sheets("output").Cells(1, 2) = "Risk"  
Sheets("output").Cells(1, 3) = "Time"  
Sheets("output").Cells(1, 4) = "Survivability"  
Sheets("output").Cells(1, 5) = "Weighted Survivability"
```

```
sink = InputBox("Enter node number for drop off of supplies", "Supply Drop Off Node",  
numnodes)
```

```
rownum = 2  
Sheets("output").Cells(rownum, 1) = sink  
Sheets("output").Cells(rownum, 2) = risk(sink) - risk(previous(sink))  
Sheets("output").Cells(rownum, 3) = (time(sink) - time(previous(sink))) * 24  
Sheets("output").Cells(rownum, 4) = 1 - Sheets("output").Cells(rownum, 2)  
Sheets("output").Cells(rownum, 5) = Sheets("output").Cells(rownum, 3) *  
Sheets("output").Cells(rownum, 4)  
Sheets("output").Cells(rownum, 5) = Sheets("output").Cells(rownum, 3) *  
Sheets("output").Cells(rownum, 4)
```

```
rownum = rownum + 1  
count = previous(sink)  
While count > 0  
    Sheets("output").Cells(rownum, 1) = count  
    Sheets("output").Cells(rownum, 2) = risk(count) - risk(previous(count))  
    Sheets("output").Cells(rownum, 3) = (time(count) - time(previous(count))) * 24  
    Sheets("output").Cells(rownum, 4) = 1 - Sheets("output").Cells(rownum, 2)  
    Sheets("output").Cells(rownum, 5) = Sheets("output").Cells(rownum, 3) *  
Sheets("output").Cells(rownum, 4)  
    rownum = rownum + 1  
    count = previous(count)  
Wend  
Sheets("output").Cells(rownum - 1, 2) = 0  
Sheets("output").Cells(rownum - 1, 4) = 1
```

```
rownum = rownum + 1  
Sheets("output").Cells(rownum, 2) = "=sum(b2:" & "b" & rownum - 1 & ")"  
Sheets("output").Cells(rownum, 3) = "=sum(c2:" & "c" & rownum - 1 & ")"  
Sheets("output").Cells(rownum, 4) = "=product(d2:" & "d" & rownum - 1 & ")"  
Sheets("output").Cells(rownum, 5) = "=sum(e2:" & "e" & rownum - 3 & ")/sum(c2:" & "c" &  
rownum - 3 & ")"  
rownum = rownum + 2
```

'Get shortest risk paths'

```
Call Dijkstra(Source, sink, rownum)  
Call getalldata  
End Sub
```

Sub Dijkstra(start_node As Integer, end_node As Integer, rownum2 As Integer)

| | |
|---------------------------|---|
| Dim Rad_lat_i As Double | 'Declare Latitude of Point "i" in Radians' |
| Dim Rad_lat_j As Double | 'Declare Latitude of Point "j" in Radians' |
| Dim Rad_lon_i As Double | 'Declare Longitude of Point "i" in Radians' |
| Dim Rad_lon_j As Double | 'Declare Longitude of Point "j" in Radians' |
| Dim DD_lat_i As Double | 'Declare Latitude of Point "i" in Degrees' |
| Dim DD_lon_i As Double | 'Declare Longitude of Point "i" in Degrees' |
| Dim DD_lat_j As Double | 'Declare Latitude of Point "j" in Degrees' |
| Dim DD_lon_j As Double | 'Declare Longitude of Point "j" in Degrees' |
| Dim COSS As Double | 'Declare Cosine of Distance between Points "i" and "j"' |
| Dim ACOSS As Double | 'Declare ArcCosine of Distance between Points "i" and "j"' |
| Dim DISTs As Double | 'Declare Cosine of Distance between Points "i" and "j"' |
| Dim lat_d As Double | 'Declare Degrees of Latitude of Point "i"' |
| Dim lat_m As Double | 'Declare Minutes of Latitude of Point "i"' |
| Dim lat_s As Double | 'Declare Seconds of Latitude of Point "i"' |
| Dim lat As Double | 'Declare Latitude of Point "i" in Radians' |
| Dim lon_d As Double | 'Declare Degrees of Latitude of Point "i"' |
| Dim lon_m As Double | 'Declare Minutes of Latitude of Point "i"' |
| Dim lon_s As Double | 'Declare Seconds of Latitude of Point "i"' |
| Dim lon As Double | 'Declare Longitude of Point "i" in Radians' |
| Dim point() As Double | Point[i][1] Latitude degrees at point "i" Point[i][2] Latitude minutes at point "i" Point[i][3] Latitude seconds at point "i" Point[i][4] Longitude degrees at point "i" Point[i][5] Longitude minutes at point "i" Point[i][6] Longitude seconds at point "i" Point[i][7] Solar Azimuth at point "i" Point[i][8] Solar Altitude at point "i" Point[i][9] Geocentric Latitude of point "i" Point[i][10] Longitude of point "i" |
| Dim boat_speed As Double | 'Declare Boat Speed' |
| Dim boat_width As Double | 'Declare Boat Width' |
| Dim river_speed As Double | 'Declare River Speed' |
| Dim ratio_earth As Double | 'Declare Ratio Earth' |
| Dim pi As Double | 'Declare the Mathematical Constant Pi' |
| Dim hour As Double | 'Declare Hours' |
| Dim min As Double | 'Declare Minutes' |
| Dim sec As Double | 'Declare Seconds' |
| Dim day As Double | 'Declarate Day' |
| Dim month As Double | 'Declare Month' |
| Dim year As Double | 'Declare Year' |
| Dim JD As Double | 'Declare Julian Date' |
| Dim start_time As Double | 'Declare Start Time' |
| Dim UT As Double | 'Declare Universal Time' |
| Dim DS As Integer | 'Declare Daylight Saving' |
| Dim t As Double | 'Declare the Auxiliari Variable "t"' |
| Dim numnodes As Long | 'Declare the Total Number of Nodes' |

| | |
|--------------------------------|---|
| Dim Q() As Double | 'Declare the set Q' |
| Dim adj() As Integer | 'Declare the Adjacent Node' |
| Dim adj_risk() As Double | 'Declare the Risk of Adjacent Node' |
| Dim adj_time() As Double | 'Declare the Time between Adjacent Nodes' |
| Dim previous() As Long | 'Declare the Previous node' |
| Dim risk() As Double | 'Declare the Risk' |
| Dim time() As Double | 'Declare the time' |
| Dim gap As Integer | 'Declare the Gap' |
| Dim k As Integer | 'Declare the Auxiliar Variable "k"' |
| Dim m As Integer | 'Declare the Auxiliar Variable "m"' |
| Dim i As Integer | 'Declare the node "i"' |
| Dim j As Integer | 'Declare the node "j"' |
| Dim infity As Double | 'Declare the infinity number' |
| Dim count As Double | 'Declare the counter' |
| Dim TZ As Double | 'Declare the Time-Zone' |
| Dim Source As Integer | 'Declare the Source Node' |
| Dim temp1 As Double | 'Declare the Auxiliar Variable "temp 1"' |
| Dim temp2 As Double | 'Declare the Auxiliar Variable "temp 2"' |
| Dim temptime As Double | 'Declare the Auxiliar Variable "temp"' |
| Dim alt_risk As Double | 'Declare the Auxiliar Variable "alt_risk"' |
| Dim sink As Integer | 'Declare the Auxiliar Variable "sink"' |
| Dim rownum As Integer | 'Declare the Row Number' |
| Dim firstnode As Integer | 'Declare the First Node to be visited' |
| Dim secondnode As Integer | 'Declare the Second Node to be visited' |
| Dim temp As Integer | 'Declare the Auxiliar Variable "temp"' |
| Dim timestep As Integer | 'Declare the Auxiliar Variable "timestep"' |
| Dim startsum As Integer | 'Declare the Auxiliar Variable "startsum"' |
| Dim minutes_between As Integer | 'Declare the Auxiliar Variable "minutes_between"' |

```

minutes_between = CInt(InputBox("Enter the number of minutes between each test path",
"Time between Paths", 15))
'Count Number of Nodes'
numnodes = 13
While Sheets("Input").Cells(numnodes, 2) <> ""
numnodes = numnodes + 1
Wend
numnodes = numnodes - 13

```

'Redimension variables'

| | |
|--|--|
| ReDim Q(numnodes, 2) As Double | 'Redimension of the number of Nodes' |
| ReDim adj(numnodes, numnodes) As Integer | 'Redimension of the Adjacent Node' |
| ReDim adj_risk(numnodes, numnodes) As Double | 'Redimension of the Risk of the Adjacent Nodes' |
| ReDim adj_time(numnodes, numnodes) As Double | 'Redimension of the Time between Adjacent Nodes' |
| ReDim previous(numnodes) As Long | 'Redimension of the Previous Node' |
| ReDim risk(numnodes) As Double | 'Redimension of the Risk' |
| ReDim time(numnodes) As Double | 'Redimension of the Time' |
| ReDim point(numnodes, 10) | 'Redimension of the Node' |

rownum = rownum2

While (Sheets("Input").Cells(3, 6) + (Sheets("Input").Cells(4, 6) / 60)) <= Sheets("Input").Cells(5, 8)

'Get variables'

TZ = Worksheets("Input").Cells(2, 6).Value
DS = Worksheets("Input").Cells(2, 8).Value
hour = Worksheets("Input").Cells(3, 6).Value
min = Worksheets("Input").Cells(4, 6).Value
sec = Worksheets("Input").Cells(5, 6).Value
day = Worksheets("Input").Cells(3, 4).Value
month = Worksheets("Input").Cells(4, 4).Value
year = Worksheets("Input").Cells(5, 4).Value
boat_width = Worksheets("Input").Cells(7, 4).Value
boat_speed = Worksheets("Input").Cells(8, 4).Value
ratio_earth = Worksheets("Input").Cells(9, 4).Value
pi = Application.WorksheetFunction.pi()

'Get Time Zone'

'Get Daylight Savings'

'Get Hours'

'Get Minutes'

'Get Seconds'

'Get Days'

'Get Months'

'Get Years'

'Get the Boath Width'

'Get the Boat Speed'

'Get the Ratio of the Earth'

'Get the the Mathematical constant Pi '

For i = 1 To numnodes

'Calculate Geocentric Latitude and Longitude of Start Point in Radians'

point(i, 1) = Worksheets("Input").Cells(12 + i, 4).Value 'Get Degrees of Latitude of Point "i"
lat_d = point(i, 1)
point(i, 2) = Worksheets("Input").Cells(12 + i, 5).Value 'Get Minutes of Latitude of Point "i"
lat_m = point(i, 2)
point(i, 3) = Worksheets("Input").Cells(12 + i, 6).Value 'Get Seconds of Latitude of Point "i"
lat_s = point(i, 3)
point(i, 4) = Worksheets("Input").Cells(12 + i, 7).Value 'Get Degrees of Longitude of Point "i"
lon_d = point(i, 4)
point(i, 5) = Worksheets("Input").Cells(12 + i, 8).Value 'Get Minutes of Longitude of Point "i"
lon_m = point(i, 5)
point(i, 6) = Worksheets("Input").Cells(12 + i, 9).Value 'Get Seconds of Longitude of Point "i"
lon_s = point(i, 6)

'Calculate Latitude of Start Point in Degrees'

DD_lat_i = lat_d + lat_m / 60 + lat_s / 3600

'Calculate Latitude of Start Point in Radians'

Rad_lat_i = WorksheetFunction.Radians(DD_lat_i)

'Calculate Longitude of Start Point in Degrees'

DD_lon_i = lon_d + lon_m / 60 + lon_s / 3600

'Calculate Longitude of Start Point in Radians'

Rad_lon_i = WorksheetFunction.Radians(DD_lon_i)
point(i, 10) = Rad_lon_i

'Calculate Geocentric Latitude of Start Point in Radians'

```
lat = Atn((1 - (1 / 2983) ^ 2) * Tan(Rad_lat_i))
point(i, 9) = lat
Next i
```

infty = 9999999

'Get adjacency matrix and put in adj(I,j)'

```
count = 81
While Sheets("Input").Cells(count, 2) <> ""
    adj(Sheets("Input").Cells(count, 2), Sheets("Input").Cells(count, 3)) = 1
    adj(Sheets("Input").Cells(count, 3), Sheets("Input").Cells(count, 2)) = 1
    count = count + 1
Wend
```

'Initalize Variables'

'Calculate Universal Time (UT)'

```
If (hour + min / 60 + sec / 3600 + DS - TZ) < 0 Then
    UT = (hour + min / 60 + sec / 3600 + DS - TZ) + 24
ElseIf (hour + min / 60 + sec / 3600 + DS - TZ) > 24 Then
    UT = (hour + min / 60 + sec / 3600 + DS - TZ) - 24
Else
    UT = (hour + min / 60 + sec / 3600 + DS - TZ)
End If
```

'Calculate the Julian Date'

```
JD = 367 * year - Int(7 * (year + Int((month + 9) / 12)) / 4) - Int(3 * (Int((year + (month - 9) / 7) / 100) + 1) / 4) + Int(275 * month / 9) + day + 1721028.5 + UT / 24
```

start_time = JD

Source = start_node 'get start node

For i = 0 To numnodes

Q(i, 1) = i

Q(i, 2) = infty

risk(i) = infty

previous(i) = infty

time(i) = start_time

Next i

'Initialization Procedures'

'Put all nodes in Q'

'Unknown distance function from source to "v"'

'Total risk of shortest path to node "i"'

'Node from which traveled to node "i" in optimal path from source'

'Travel time to node "i"'

'Start the Algorithm

risk(Source) = 0

Q(Source, 2) = 0

Q(0, 2) = -1 * infty

previous(Source) = 0

'Distance from source to source'

Do

'The main loop'

'Sort Q by risk'

```
gap = (numnodes - 1) / 2
While (gap > 0)
  For k = gap To numnodes
    For m = k - gap To 0 Step -gap
      If (Q(m, 2) > Q(m + gap, 2)) Then
        temp2 = Q(m, 2)
        temp1 = Q(m, 1)
        Q(m, 2) = Q(m + gap, 2)
        Q(m + gap, 2) = temp2
        Q(m, 1) = Q(m + gap, 1)
        Q(m + gap, 1) = temp1
      End If
    Next m
  Next k
  gap = gap / 2
Wend
```

```
If Q(1, 2) = infity Then
  Exit Do          'All remaining vertices are inaccessible from source'
End If
Q(1, 2) = infity  'Remove u from Q sets dist to infinity so wont appear in sort'
```

'Removes "u" from adjacency matrix for next operation'

```
For i = 1 To numnodes
  adj(Q(1, 1), i) = 0
Next i
```

'For each neighbor "v" of "u": where "v" has not yet been removed from Q'

```
For i = 1 To numnodes
  If adj(i, Q(1, 1)) = 1 Then
```

'Compute risk for time(q(1,1)) based on coming from node Q(1,1) to node "i"'

'Calculate Cosine of Distance between Points "i" and "j"'

```
COSS = Sin(point(i, 9)) * Sin(point(Q(1, 1), 9)) + Cos(point(i, 9)) * Cos(point(Q(1, 1), 9)) *
Cos(point(i, 10) - point(Q(1, 1), 10))
```

'Calculate Distance between Points "i" and "j"'

```
ACOSS = Application.WorksheetFunction.Acos(COSS)
```

'Calculate Distance between Points "i" and "j" in miles'

```
DISTS = ACOSS * ratio_earth
```

```
temptime = time(Q(1, 1)) + (DISTS / boat_speed) / 24
```

```
alt_risk = risk(Q(1, 1)) + travel_risk(Q(1, 1), i, temptime)
```

```
If alt_risk < risk(i) Then 'Relax (u,v,a)'
```



```
risk(i) = alt_risk
previous(i) = Q(1, 1)
```

```
For j = 1 To numnodes
  If Q(j, 1) = i Then Q(j, 2) = risk(i)
Next j
time(i) = temptime
ElseIf alt_risk = risk(i) And temptime < time(i) Then
  risk(i) = alt_risk
  previous(i) = Q(1, 1)
  For j = 1 To numnodes
    If Q(j, 1) = i Then Q(j, 2) = risk(i)
  Next j
  time(i) = temptime
```

```
End If
End If
```

```
Next i
```

```
Loop Until numnodes < 0
```

'Loop until all nodes have been evaluated'

```
'Get apth risk and time traveled'
Sheets("output").Cells(rownum, 1) = "Path " & Sheets("Input").Cells(3, 6) & ":" &
Format(Sheets("Input").Cells(4, 6), "00")
Sheets("output").Cells(rownum, 2) = "Risk"
Sheets("output").Cells(rownum, 3) = "Time"
Sheets("output").Cells(rownum, 4) = "Survivability"
Sheets("output").Cells(rownum, 5) = "Weighted Survivability"
Sheets("output").Cells(rownum, 5) = "Weighted Survivability"
```

```
sink = end_node
rownum = rownum + 1
startsum = rownum
Sheets("output").Cells(rownum, 1) = sink
Sheets("output").Cells(rownum, 2) = risk(sink) - risk(previous(sink))
Sheets("output").Cells(rownum, 3) = (time(sink) - time(previous(sink))) * 24
Sheets("output").Cells(rownum, 4) = 1 - Sheets("output").Cells(rownum, 2)
Sheets("output").Cells(rownum, 5) = Sheets("output").Cells(rownum, 3) *
Sheets("output").Cells(rownum, 4)
```

```
rownum = rownum + 1
count = previous(sink)
While count > 0
  Sheets("output").Cells(rownum, 1) = count
  Sheets("output").Cells(rownum, 2) = risk(count) - risk(previous(count))
  Sheets("output").Cells(rownum, 3) = (time(count) - time(previous(count))) * 24
  Sheets("output").Cells(rownum, 4) = 1 - Sheets("output").Cells(rownum, 2)
  Sheets("output").Cells(rownum, 5) = Sheets("output").Cells(rownum, 3) *
Sheets("output").Cells(rownum, 4)
  rownum = rownum + 1
  count = previous(count)
```

```

Wend
Sheets("output").Cells(rownum - 1, 2) = 0
Sheets("output").Cells(rownum - 1, 4) = 1

rownum = rownum + 1
Sheets("output").Cells(rownum, 2) = "=sum(b" & startsum & ":" & "b" & rownum - 1 & ")"
Sheets("output").Cells(rownum, 3) = "=sum(c" & startsum & ":" & "c" & rownum - 1 & ")"
Sheets("output").Cells(rownum, 4) = "=product(d" & startsum & ":" & "d" & rownum - 1 &
")"
Sheets("output").Cells(rownum, 5) = "=sum(e" & startsum & ":" & "e" & rownum - 3 &
)/sum(c" & startsum & ":" & "c" & rownum - 3 & ")"
rownum = rownum + 2
If Sheets("Input").Cells(4, 6) = 60 - minutes_between Then
    Sheets("Input").Cells(4, 6) = 0
    Sheets("Input").Cells(3, 6) = Sheets("Input").Cells(3, 6) + 1
Else
    Sheets("Input").Cells(4, 6) = Sheets("Input").Cells(4, 6) + minutes_between
End If
Wend
End Sub

```

```

Sub getalldata()

```

```

'Create coluns on the "Output Spreadsheet" with the Total Calculated Outcomes'

```

```

On Error GoTo 100

```

```

Dim count As Integer

```

```

Dim rownum As Integer

```

```

count = 2

```

```

rownum = 2

```

```

While count < 50000

```

```

    While Left(Sheets("Output").Cells(count, 1), 4) <> "Path"

```

```

        count = count + 1

```

```

    Wend

```

```

    Sheets("output").Cells(rownum, 10) = LTrim(Right(Sheets("output").Cells(count, 1), 5))

```

```

    While Sheets("output").Cells(count, 1) <> ""

```

```

        count = count + 1

```

```

    Wend

```

```

    Sheets("output").Cells(rownum, 11) = Sheets("output").Cells(count + 1, 2)

```

```

    Sheets("output").Cells(rownum, 12) = Sheets("output").Cells(count + 1, 3)

```

```

    Sheets("output").Cells(rownum, 13) = Sheets("output").Cells(count + 1, 4)

```

```

    Sheets("output").Cells(rownum, 14) = Sheets("output").Cells(count + 1, 5)

```

```

    rownum = rownum + 1

```

```

    count = count + 1

```

```

    Wend

```

```

100

```

```

End Sub

```

Appendix C: Blue Dart

Fabio Ayres Cardoso, Captain, Brazilian Air Force
(55-21) 2453-0604, cardosoaf@yahoo.com.br
word count:

Stealthy River Navigation in Jungle Combat Conditions

It's common sense that logistics is fundamental for conducting war at the operational level. To keep fighting in the inherently chaotic and frictional environment, combat units need to be constantly supported and resupplied of items that are consumed during the battle. In certain places, like the jungle and tropical rainforests, terrain conditions and climate offer an extra dimension to military operations which needs to be carefully considered in addition to enemy actions. However, if local features are exploited they can become a notable ally to sustain and prolong military campaigns.

For example, under a logistic perspective, jungle surroundings provide excellent camouflage for stationary entities like storage depots, airfields, and camps. The jungle camouflage also provides a means to effectively hide and cover mobile units such as trucks, airplanes, and boats. These deny and deceive strategies are especially important to protect the supply chains set up between depots and combat forces which opposing forces are constantly trying to disrupt. A key aspect of military logistics is to preserve lines of communication and supply between suppliers and deployed troops under enemy threat.

The above mentioned covert conduct of logistics, also called stealthy navigation, uses local attributes to conceal movement. In jungle areas, the most obvious method to avoid enemy detection is to take advantage of shadows or dark areas provided by large and dense vegetation. However, it requires both good knowledge of the actual

environment as well as skills and judgment to maximize benefits. Nowadays, this kind of discernment can be obtained using computational models which combine local characteristics with optimization tools. This research combines a solar position calculator to estimate shade areas along a river and a graph algorithms to compute combinations of available paths. When combined, it's possible to schedule sorties over a river network in a jungle context reducing the likelihood of detection by enemy forces and the confiscation or destruction of supplies.

That approach offers different and complementary advantages:

- a) It presents a way to save military assets in combat zones by reducing the demand for armed escort across watercourses. These forces are now available for offensive actions.
- b) It matches the strategy employed by jungle warriors in terms of furtive actions, covert movements, and denied existence.
- c) It provides a means to greatly reduce supply chain costs. By using the local environment to conceal movement, boats do not have to be made of technologically advanced materials that provide very weak radar returns.

Key words: jungle warfare, travel risk minimization, river network, stealthy navigation.

“Captain Fabio Ayres Cardoso is Master’s degree student from the Air Force Institute of Technology.”

Appendix D: Quad Chart



Stealthy River Navigation in Jungle Combat Conditions





PROBLEM STATEMENT

A small deployed combat force requires time-dependent resupply in a hostile jungle environment, under the constraints of exposure to enemy fire (aircraft, helicopters, and unmanned aerial vehicles). Planners must select among the available watercourses ones that provide stealthy navigation to the combat force location where the requested supplies are safely unloaded.

LIMITATIONS AND ASSUMPTIONS

- Chaos (chance and uncertainty) and friction (resistance and antagonism) are essential elements of the battlefield, but aren't modeled.
- The dynamic nature of the watercourse network isn't modeled. The environmental effect of fog at sunrise and sunset due to the high humidity of tropical rain forests, as well as the excessive condensation on dry seasons is not modeled. Additionally, the major river attributes (flow speed and depth) as well as the forest riverine feature variations through the path are also completely neglected.
- The risk calculation which considers an omnipresent enemy exacerbates the potential sources of mission non-fulfillment creating the most pessimistic scenario, which is, by definition, very improbable.
- The model accurately calculates both safe routes and better start-times for delivery of supplies to deployed units only during daylight travel.
- The model ignores the return trip of the boat to the depot as well as its implications for future missions.

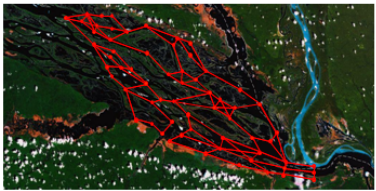

Plotted Network Diagram used in Model Development
(Satellite photo of Amazon River basin)

Capt. Fabio Ayres Cardoso
AFIT/ENS
ADVISOR
Dr. Alan Johnson
READER
Major Daniel Mattiotta, PhD

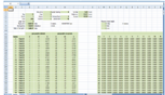

Input interface

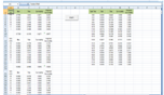

Output interface

$$\sum_{i=j}^N \lambda_{it} \text{ Total Risk}$$

$$\prod_{i=j}^N (1 - \lambda_{it}) \text{ Survivability (probability of mission success)}$$

$$\sum_{i=j}^N \frac{(1 - \lambda_{it}) \tau_i}{T} \text{ Weighted-Survivability (importance of time exposure)}$$

Legend:
 λ_{it} : Risk on ac J at time t
 τ_i : Travel time on ac J
 T : Total travel time.

MODEL TESTING
(Data Analysis, Extreme Conditions Tests, Cause and Effect Graphing and Predictive Validation)

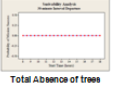

Total Absence of trees

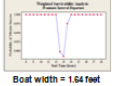

Boat width = 1.64 feet

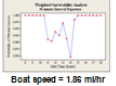

Boat speed = 1.98 mi/hr



Total Absence of trees

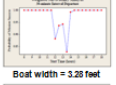

Boat width = 3.20 feet

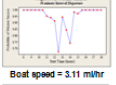

Boat speed = 3.11 mi/hr

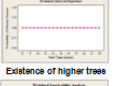

Existence of higher trees

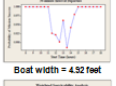

Boat width = 4.92 feet



Boat speed = 6.21 mi/hr

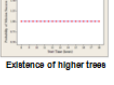

Existence of higher trees



Boat width = 6.56 feet

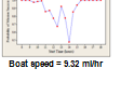

Boat speed = 9.32 mi/hr

INSIGHTS

- Research identifies benefits of concealment schemes used to avoid detection and movement tracking in terms of position and speed.
- Changes in risk quantifier parameters don't affect proportionally and equally the boat vulnerability through the route. Increasing boat speed demonstrates low impact in reducing boat vulnerability. On the other hand, small variations on boat width produces large consequences for risk travel. Thus, boat width is an important consideration during the stealthy supply watercraft design process.
- Different analytic approaches to the same operational scenario provides military planners the ability to attain simultaneously tactical and logistics objectives. The outcomes are compatibly displayed with their goals.

FUTURE RESEARCH

- Increase the number of units deployed on the battlefield to evaluate the optimal start-time and boat dimensions.
- Change environment features such as river flow speed (direction and intensity), and river depth (include seasonal alterations) which can affect boat transit capability.
- Evaluate the optimal depot location to minimize total travel risk between the depot and the deployed fighting forces given a network and theater operations boundaries.
- Include the moon luminosity influence on exposure level calculations during network night crossing.
- Develop other combat logistics effectiveness measures for assessing travel network vulnerability to include fuel consumption rate, defense posture, and detection avoidance from water and aerial searches.

DEPARTMENT OF OPERATIONAL SCIENCES

Bibliography

Abu-Taieh, Evon and others. *Handbook of Research on Discrete Event Simulation Environments: Technologies and Applications*. Hershey PA: Information Science Reference 2009.

Anderson, Charles Robert. *Leyte: U.S. Army Campaigns of World War II (Pamphlet)*. U.S. Army Campaigns of World War II, CMH Pub. 72-27, Army Center of Military History, 1994.

Anderson, Charles Robert. *Guadalcanal: U.S. Army Campaigns of World War II (Pamphlet)*. U.S. Army Campaigns of World War II, CMH Pub. 72-8, Army Center of Military History, 1993.

Asner, Gregory P. and others. "Estimating Canopy Structure in an Amazon Forest from Laser Range Finder and IKONOS Satellite Observations". *Biotropica*, 34(4):483-492 (2002).

Asprey, Robert B. *War in Shadows: The Guerilla History – Volume II*. Lincoln NE: iUniverse Inc, 2002.

Astor, Gerald. *The Jungle Warfare: Maverick, Marauders, and Madmen in the China-Burma-India Theater of WWII*. Hoboken NJ: John Wiley & Sons, Inc, 2004.

Avron, Arnon and others. *Pillars of Computer Science: Essays Dedicated to Boris (Boaz) Trakhtenbrot on the Occasion of His 85th Birthday (Lecture Notes in Computer Science / Theoretical Computer Science and General Issues)*. New York NY: Springer, 2008.

Bennett, Thomas B. *Night Jungle Operations*. Monograph, School of Advanced Military Studies, United States Army Command and General Staff College, Fort Leavenworth KS, 1993.

Birgersson, Emil and others. "Toward Stealthy Behavior". Las Vegas, NV: *IEEE/RSJ International Conference on Intelligent Robots and Systems*, 1703-1708 (2003).

Bronstein, I. N. and others. *Handbook of Mathematics*. New York NY: Springer, 2007.

Bubak, Marian and others. "Computational Science - ICCS 2004: 4th International Conference, Kraków, Poland, June 6-9, 2004". *Proceedings, Part IV: Lecture Notes in Computer Science*. New York NY: Springer, July 2004.

Bull, Stephen. *World War II Jungle Warfare Tactics*. Oxford United Kingdom: Osprey Publishing, 2007.

Calow, Peter P. *Blackwell's Concise Encyclopedia of Environmental Management*. Sheffield, England: Wiley-Blackwell, August 1999.

Camm, Frank and Victory A. Greefield. "How Should the Army Use Contractors on the Battlefield? Assessing Comparative Risk in Sourcing Decisions". Santa Monica CA: *RAND Monograph*. RAND Corporation, 2005.

Cambridge. *Cambridge Advanced Learner's Dictionary with CD-ROM*. United Kingdom Cambridge: Cambridge University Press, 3rd Edition, 2008.

Campbell, James. *The Ghost Mountain Boys: Their Epic March and the Terrifying Battle for New Guinea –The Forgotten War of the South Pacific*. New York NY: Three Rivers Press, September 2008.

Carruthers D, Uloth C. and Roy G. G. *An Evaluation of Formulae for Solar Declination and the Equation of Time*. Research Report No RR17, School of Architecture, The University of Western Australia, January 1990.

Castillo, Enrique and others. *Expert Systems and Probabilistic Network Models (Monographs in Computer Science)*. New York NY: Springer, December 1996.

Chambers. *The Chambers Dictionary*. United Kingdom Edinburgh: Chambers Harrap Publishers Ltd, 11th Edition, 2008.

Chung, Christopher A. *Simulation Modeling Handbook: A Practical Approach*. New York NY: CRC Press, 2006

Clausewitz, Carl Von. *On War*. Penguin Classics, Abridged edition, November 1982.

Coffin, Timothy R. *Company Level Logistics on the Future Battlefield*. Monograph, School of Advanced Military Studies, United States Army Command and General Staff College, Fort Leavenworth KS, 1993.

Collins, John M. "Going to Tchepone: OPLAN El Paso". Washington DC: Institute for National Strategic Studies, National Defense University, *Joint Force Quarterly*, N° 17, Autumn/Winter, 1997/1998.

Cormen, Thomas and others. *Introduction to Algorithms*. MIT Press, 2nd Edition, 2001.

Correll, John T. "The Ho Chi Minh Trail". *Air Force Magazine*. Volume 88, N° 11, November, 2005.

Cross, J. P. *Jungle Warfare: Experiences & Encounters*. Annapolis MD: Naval Institute Press, 2007.

Dasso, Aristides and Ana Funes. *Verification, Validation and Testing in Software Engineering*. Hershey PA: Idea Group Publishing, 2007.

Department of the Army. *The Armored Cavalry Regiment and Squadron – Field Manual 17-95-10*. Washington DC: Government Printing Office, 1993.

Department of the Army. *US Army Guerrilla Warfare Handbook*. New York NY: Skyhorse Publishing Inc, 2009.

Department of the Navy. *Jungle Warfare. Fleet Marine Force Reference Publication (FMFRP) 12-9*. Washington DC: April 1989.

Dobbie, James M. “Some Search Problems with False Contacts”. *Operations Research*, 21:907-919 (1973)

Drea, Edward J. *New Guinea: The U.S. Army Campaigns of World War II (Pamphlet)*. U.S. Army Campaigns of World War II, CMH Pub. 72-9, Army Center of Military History, 2008.

Du, Ding-Zhu and others. *Combinatorial Optimization and Applications: Third International Conference, COCOA 2009, Huangshan, China, June 2009, Proceedings*. New York NY: Springer, 2009.

Duffett-Smith, Peter. *Practical Astronomy with your Calculator*. Cambridge CB: Cambridge University Press, March 1988.

Dupuy, T. N. *Numbers, Predictions and War: Using History to Evaluate Combat Factors and Predict the Outcome of Armed Conflict*. Fairfax VA: Hero Books, 1985.

Eccles, Henry. *Logistics in the National Defense*. Westport CT: Greenwood Press Publishers, 1981.

Epstein, Joshua M. *The Calculus of Conventional War: Dynamic Analysis without Lanchester Theory*. Washington DC: The Brookings Institution, 1985.

Gardiner, Juliet. *The Animals' War: Animals in Wartime from the First World War to the Present Day*. Portrait, May 2006.

Gregory, Charles R. *Guerrilla Force: Can We Support Them?* Monograph, School of Advanced Military Studies, United States Army Command and General Staff College, Fort Leavenworth KS, 1987.

Grena, Roberto. “An Algorithm for the computation of solar position”. *Solar Energy*: 462-470 (2008).

Gross, Jonathan L. and Jay Yellen. *Graph Theory and Its Applications*. Boca Raton FL: CRC Press, December 1998.

Guarino, Nicola. "Concepts, Attributes, and Arbitrary Relations: Some Linguistic and Ontological Criteria for Structuring Knowledge Bases". *Data and Knowledge Engineering*, 8: 249-261 (1992).

Haldi, Stacy Bergstrom. "The Influence of Logistics on War Widening". *Defense & Security Analysis*, 18:3-14 (2002).

Hansson, Sven Ove. *Philosophical Perspectives on Risk*. Stockholm: Royal Institute of Technology. 2002.

Harcourt, Houghton Mifflin. *American Heritage Dictionary of the English Language*. Houghton Mifflin Harcourt. April 2006.

Haug, Michael and others. *Software Quality Approaches: Testing, Verification and Validation*. New York NY: Springer, 2001.

Heiser, Joseph. *Logistics Support Vietnam Studies*. Vietnam Studies, CMH Pub. 90-15, Army Center of Military History, 1974.

Hong, Sung-Pil and others. "A Pseudo-polynomial Heuristic for Path-constrained Discrete-time Markovian-target Search". *European Journal of Operational Research*, 193: 351-364 (2009).

Hornby, Albert Sydney. *Oxford Advanced Learner's Dictionary: Of Current English*. United Kingdom Oxford: Oxford University Press, 7th Edition, 2007.

Iqbal, Muhammad. *An Introduction to Solar Radiation*. Academic Press Inc, 1983.

Kane, Thomas. *Military Logistics and Strategic Performance (Class Series – Strategy and History)*. Portland OR: Frank Cass Publishers, 2001.

Kant, Kamal and Steven W. Zucker, "Toward Efficient Trajectory Planning: The Path-velocity Decomposition" *Int. Robotics Res*, 5:72-89 (1987).

Kent, Allen and James G. Williams. *Encyclopedia of Computer Science and Technology: Volume 23 – Supplement 8: Approximation: Optimization, and Computing to Visual Thinking*. CRC Press, August 1990.

Kheir, Naim A. *Systems Modeling and Computer Simulation*. New York NY: Marcel Decker Inc., 1996.

Kress, Moshe. *Operational Logistics: The Art and Science of Supporting Military Operations*. Norwel MA: Kluwer Academic Publishers, 2002.

LaValle, Steven Michael. *Planning Algorithms*. New York NY: Cambridge University Press, 2006.

Law, Averill M. *Simulation Modeling and Analysis*. New York NY: McGraw-Hill Higher Education, Fourth Edition, 2007.

Lawson, William. *Outlines of Mathematical and Physical Geography*. Edinburgh London: Oxford University. Reprinted from 1864 edition, 2008.

Ledin, Jim. *Simulation Engineering*. Berkeley CA: CPM Books, 2001.

Leedy, Paul D. and Jeanne Ells Ormrod. *Practical Research: Planning and Desing*. Boston MA: Pearson Education Inc, 2009.

Lenhard, Johannes and others. *Simulation: Pragmatic Construction of Reality*. Dordrecht Netherlands: Springer, 2006.

Marion, Ore J. and others. *On the Canal: The Marines of L-3-5 on Guadalcanal, 1942*. Mechanicsburg PA: Stackpole Military History Series. 2004.

McClain, Michael and others. *The Biogeochemistry of the Amazon Basin*. New York NY: Oxford University Press, 2001.

Merriam-Webster. *Merriam-Webster's Collegiate Dictionary*. Merriam-Webster Inc. 11th Edition, 2003.

Michalsky, Joseph J. "The Astronomical Almanac's Algorithm for Approximate Solar Position (1950–2050)". *Solar Energy* 40: 227–235 (1988).

Moore, Michael L. *A Review of Search and Reconnaissance Theory Literature*. The University of Michigan and Ann Arbor Systems Research Laboratory. January 1970.

Morse, Philip M. and George E. Kimball. *Methods of Operations Research*. Alexandria VA: Military Operations Research Society. 1998.

Moreman, Tim. *The Jungle, Japanese and the British Commonwealth Armies at War, 1941-45: Fighting Methods, Doctrine and Training for Jungle Warfare (Military History and Policy)*. New York NY: Frank Cass, 2005.

Nalty, Bernard C. *The War Against Trucks: Aerial Interdiction in Southern Laos (1968-1972)*. Washington DC: United States Air Force History and Museum Program, 2005.

Newell, Clayton R. *The Framework of Operational Warfare*. New York NY: Routledge, 1991.

O'Hanlon, Michael E. *The Science of War: Defense Budgeting, Military Technology, Logistics, and Combat Outcomes*. Oxfordshire United Kingdom: Princeton University Press, 2009.

O'Sullivan, Patrick Michael and Jesse Miller. *The Geography of Warfare*. New York NY: St. Martin's Press, 1983.

Papadimitriou, Christos H. and Kenneth Steiglitz. *Combinatorial Optimization: Algorithms and Complexity*. Mineola NY: Dover Publications, 1998.

Pinkston, B. *Logistics and Nonlinearity: A Philosophical Dilemma*. Monograph, School of Advanced Military Studies, United States Army Command and General Staff College, Fort Leavenworth KS, 1995.

Procter, Paul. *Cambridge International Dictionary of English (With CD-ROM)*. Cambridge United Kingdom: Cambridge University Press, January 2001.

Przemieniecki, J. S. *Mathematical Methods in Defense Analysis*. Reston VA: American Institute of Aeronautics and Astronautics, Inc., 2000.

Rao, Gangoli Arvind and Shripad P. Mahulikar. "Integrated Review of Stealth Technology and its Role in Airpower". *The Aeronautical Journal*, 106:629-641 (2002).

Ravela, Srinivas and others. "Stealth Navigation: Planning and Behaviors". Monterey CA: *Proceedings of the ARPA Image Understanding Workshop*, 1093-1100 (1994).

Reda, Ibrahim and Afshin Andreas. "Solar Position Algorithm for Solar Radiation Applications". *Solar Energy*, 76: 577-589 (2003).

Sack, Jörg-Rüdiger and Jorge Urrutia. *Handbook of Computational Science*. Amsterdam Netherlands: North Holland, 2001.

Sandler, Stanley L. *Ground Warfare: An International Encyclopedia – Volume I*. Santa Barbara CA: ABC-CLIO Inc, 2002.

Schweitzer, P.J. and J.C. Armstrong. *A Study of Data Related to Viet Cong/North Vietnamese Army Logistics and Manpower*, under the supervision of G.W. Rathjens and H.W. Bode. Washington DC: Institute for Defense Analysis, 29 August 1966.

Scott, F. Beth and others. *The Logistics of Waging War*. Maxwell AFB Gunter Annex AL: The Air Force Logistics Management Agency, August 2000.

Soanes, Catherine. *Compact Oxford English Dictionary of Current English*. Oxford University Press, 3rd Revised Edition, 2008.

Sokolowski, John A. and Catherine M. Banks. *Principles of Modeling and Simulation: A Multidisciplinary Approach*. Hoboken NJ: John Wiley & Sons, Inc, 2009.

Spencer, David. *Potential Conflict in Latina America*. The NIC 2020 Project, Workshop on "The Changing Nature of Warfare", Washington DC: National Intelligence Council, 25 May 2004.

Spencer, J.W. *Calculation of Solar Position for Building Purposes*. Melbourne Australia: Commonwealth Scientific and Industrial Research Organization Division of Building, Research Technical Paper No. 14, 1965.

Stone, L. D. *Theory of Optimal Search*. New York NY: Academic Press, 1975.

Szokolay, Steven. *Solar Geometry*. Passive and Low Energy Architecture International, in association with Department of Architecture. The University of Queensland, Brisbane Australia, 1996.

Taylor, Don G. *Logistics Engineering Handbook*. Boca Raton FL: CRC Press, 2007.

Teng, Daniel DeMenthon, and Larry S. Davis. "Stealth Terrain Navigation". *IEEE Transaction on Systems, Man and Cybernetics*, 23: 96-110 (1993).

Tews, Ashley and others. "Avoiding Detection in a Dynamic Environment". *IEEE RSJ International Conference on Intelligent Robots and Systems*, 4:3773-3778 (2004).

Thompson, Julian. *The Lifeblood of War: Logistics in Armed Conflict*. Brassey's UK Ltd, 1994.

Thompson, Leroy. *SAS: Great Britain's Elite Special Air Force*. Osceola WI: Zenith Press, 1994.

Thorpe, George Cyrus. *Pure Logistics: The Science of War Preparation*. Washington DC: National Defense University Press, 1986.

Trinquier, Roger. *Modern Warfare: A French View of Counterinsurgency*. Westport CT: PSI Classics of the Counterinsurgency Era, Praeger Security International, 2006.

United States Department of Defense. "Modeling and Simulation" – Washington DC: *DoD Instruction 5000.61*, 1996.

Tucker, Spencer C. and Priscilla Mary Roberts. *The Encyclopedia of World War I: A Political, Social, and Military History*. Santa Barbara CA: ABC-CLIO Inc, 2005.

Vongsavanh, Soutchat. "RLG Military Operations and Activities in the Laotian Panhandle". Washington DC: Army Center of Military History, *Indochina Monograph*. 1981.

War Department. *Jungle Warfare - Field Manual 72-20*. Washington DC: United States Government Printing Office, October 1944.

Washburn, Alan and Moshe Kress. *Combat Modeling (International Series in Operations Research & Management Science)*. New York NY: Springer, August 2009.

Young, Charles A. *Manual of Astronomy: A Text-Book*. Boston, London: Ginn & company, 1902.

Zacharias, Greg and others. *Behavioral Modeling and Simulation: From Individuals to Societies*. Washington DC: National Research Council, 2008.

Zang, Hui. *WDM Mesh Networks: Management and Survivability*. Kluwer Academic Publishers. 2002.

Zehna, Peter W. *Selected Methods and Models in Military Operations Research*. Honolulu HI: University Press of the Pacific, 2005.

Vita

Captain Fabio Ayres Cardoso graduated from the Brazilian Air Force Academy in December 1999. His first assignment was at Afonsos Air Force Base, Rio de Janeiro, as Supply and Campaign Planning Officer in February 2000. In February 2004, he was assigned to the Intendance Department, where he served in the Operational Intendance Division as both chief of Control, Doctrine and Operational Supervision Section, as well as Chief of Field Materiel Section. While stationed at the Intendance Department, he represented the Intendancy Department in the Defense Ministry's Classifying of Items and Defense Enterprises project called Enterprises Directly Related to National Security (EDRNS) System. During the period 2004-2008, he was an instructor at the Brazilian Air Force Academy (Support Logistics in Battlefield) and Brazilian Air Force School of Officer's Specialization. In August 2008, he entered the Graduate School of Engineering and Management, Air Force Institute of Technology. Upon graduation, he will be assigned to the Intendance Department, Rio de Janeiro, Brazil.

| REPORT DOCUMENTATION PAGE | | | | Form Approved OMB No. 074-0188 | |
|--|-------------|-----------------------------------|-------------------------------|--|---|
| The public reporting burden for this collection of information is estimated to average 1 hour per response, including the time for reviewing instructions, searching existing data sources, gathering and maintaining the data needed, and completing and reviewing the collection of information. Send comments regarding this burden estimate or any other aspect of the collection of information, including suggestions for reducing this burden to Department of Defense, Washington Headquarters Services, Directorate for Information Operations and Reports (0704-0188), 1215 Jefferson Davis Highway, Suite 1204, Arlington, VA 22202-4302. Respondents should be aware that notwithstanding any other provision of law, no person shall be subject to a penalty for failing to comply with a collection of information if it does not display a currently valid OMB control number. PLEASE DO NOT RETURN YOUR FORM TO THE ABOVE ADDRESS. | | | | | |
| 1. REPORT DATE (DD-MM-YYYY) 25-03-2010 | | 2. REPORT TYPE Master's Thesis | | 3. DATES COVERED (From – To) Aug 2008 – Mar 2010 | |
| 4. TITLE AND SUBTITLE STEALTHY RIVER NAVIGATION IN JUNGLE COMBAT CONDITIONS | | | | 5a. CONTRACT NUMBER | |
| | | | | 5b. GRANT NUMBER | |
| | | | | 5c. PROGRAM ELEMENT NUMBER | |
| 6. AUTHOR(S) Cardoso, Fabio A., Captain, Brazilian Air Force | | | | 5d. PROJECT NUMBER | |
| | | | | 5e. TASK NUMBER | |
| | | | | 5f. WORK UNIT NUMBER | |
| 7. PERFORMING ORGANIZATION NAMES(S) AND ADDRESS(S) Air Force Institute of Technology Graduate School of Engineering and Management (AFIT/EN) 2950 Hobson Street, Building 642 WPAFB OH 45433-7765 | | | | 8. PERFORMING ORGANIZATION REPORT NUMBER AFIT-LSCM-ENS-10-02 | |
| 9. SPONSORING/MONITORING AGENCY NAME(S) AND ADDRESS(ES) INTENTIONNALLY LEFT BLANK | | | | 10. SPONSOR/MONITOR'S ACRONYM(S) | |
| | | | | 11. SPONSOR/MONITOR'S REPORT NUMBER(S) | |
| 12. DISTRIBUTION/AVAILABILITY STATEMENT APPROVED FOR PUBLIC RELEASE; DISTRIBUTION UNLIMITED. | | | | | |
| 13. SUPPLEMENTARY NOTES | | | | | |
| 14. ABSTRACT One of the biggest challenges for Brazilian military logisticians is to support effective jungle warfare for both real and training operations carried out by their combat forces in the Amazonian region. The jungle's heat, humidity, and dense vegetation put significant demands on the supply chain. Further, because of the difficulties of land or air transportation, water transport is the most reasonable transportation option to sustain these deployed forces. Planners must select from among the available watercourses those whose surroundings provide stealthy navigation to the combat force location where the requested supplies can be safely unloaded. We seek a method of determining a path through a river network that blends short transit times with maximal shade coverage from forest growth along the riverbanks. We combine an astronomical algorithm for computing shadow coverage with Dijkstra's shortest path algorithm to determine the start time and routing information necessary for a supply boat to travel from a depot to a resupply point that minimizes weighted risk, which is defined as the product of shade coverage and arc transit time. | | | | | |
| 15. SUBJECT TERMS Amazon Region, Dijkstra's Algorithms, Jungle Warfare, Travel Risk Minimization, River Network, Solar Position Algorithms, Stealthy Navigation. | | | | | |
| 16. SECURITY CLASSIFICATION OF: | | | 17. LIMITATION OF ABSTRACT | 18. NUMBER OF PAGES | 19a. NAME OF RESPONSIBLE PERSON |
| a. REPORT | b. ABSTRACT | c. THIS PAGE | | | ALAN W. JOHNSON, PhD |
| S/NF | U | U | UU | 174 | 19b. TELEPHONE NUMBER (Include area code) (937) 255-3636, x4703; e-mail: alan.johnson@afit.edu |

Standard Form 298 (Rev. 8-98)
Prescribed by ANSI Std. Z39-18